

Saaku Sauna (Helo CUP) QSG (Quick Start Guide)

Mounting Heater

See template and heater mounting instruction packed in box with heater. Drill four 9/64" holes to fasten the heater to the wall. Install two 1/4" x 1 1/2" hex head lag screws with two washers on each screw (supplied with the heater) into the upper two holes. Tighten these screws until their heads are about 1/8" from the wall surface. The screws must be threaded through the wall into a framing member or backing board to support the heater weight. Hang the heater on the two upper screws. Locate the two 1/4" x 1" hex head lag screws (supplied with the heater) then install them into the two lower mounting holes. Tighten to lock the heater in place.

Electrical Access:

1. Remove the bottom cover from under the heater.
2. Remove the lower right cover to access electrical connections.

Electrical Connection of Heater

The sauna heater must be connected to the supply voltage by a qualified electrician.

Must use 90°C rated wiring with copper wire. Heater must be grounded!

Route the feed wires through the holes provided in the bottom of the heater and connect wires under the screw terminals. See chart below for correct wire size.

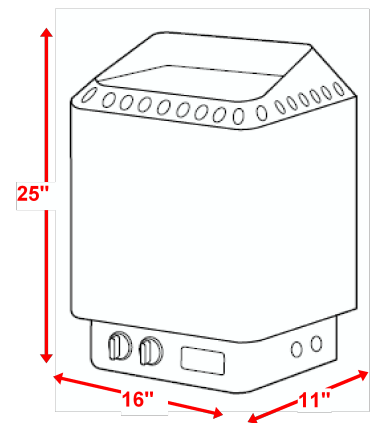

Heaters are dual rated for 230volt and 240volt, single phase.
Table below shows 240 volt North American Standards:

HEATER MODEL / Product Number	Phase	Voltage	Amps	Breaker	90 ° Wire Size (AWG)	kW
CUP 30 1712-30-171809	1	230	13.0	20	12-2 W/G	3.0
	1	240	13.3	20	12-2 W/G	3.2
CUP 45 1712-45-171809	1	230	17.4	20	10-2 W/G	4.0
	1	240	18.3	20	10-2 W/G	4.4
CUP 60 1712-60-171809	1	230	23.9	30	10-2 W/G	5.5
	1	240	25.0	30	10-2 W/G	6.0
CUP 80 1712-80-171809	1	230	31.7	40	8-2 W/G	7.3
	1	240	33.3	40	8-2 W/G	8.0
CUP 90 1712-90-171809	1	230	36.1	50	8-2 W/G	8.3
	1	240	37.9	50	8-2 W/G	9.1

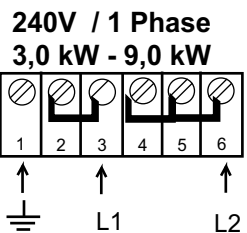
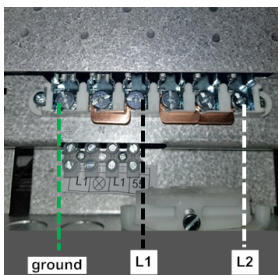

Install supply wires under screw

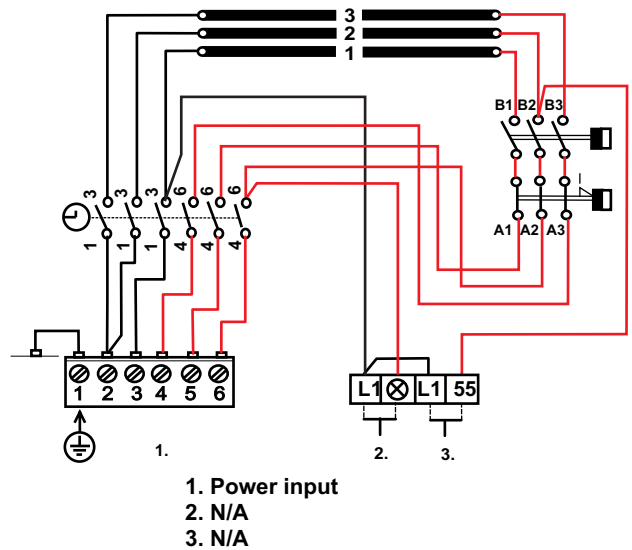

Saaku Sauna (Helo CUP) QSG (Quick Start Guide)

Timer

The sauna heater is controlled by multi-stage timer. The timer is set by twisting the knob clockwise to desired setting. 1-3 refers to the run time (1, 2, or 3 hour duration).

- 0 position. The sauna heater is off.
- Operating time 1–3 hours. To set, turn timer knob past "3", then turn back to desired duration. Recommend run time is one hour. (You will hear contactor engage when turning back to the "run zone")
- The sauna heater will heat up at full power, controlled by the sauna thermostat temperature setting.
- If the switch has not traveled back to 0 position after finishing bathing, turn it to 0 manually
- Preset Start Time: 1–9 hours.
- Turn the timer to delay zone and select the delay time (in hours). Once the delay lapses, the sauna will begin and 3 hour run cycle.

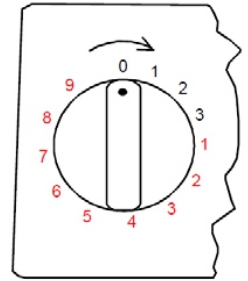

Thermostat

The thermostat knob is next to the timer knob. The further right (clockwise) the knob is switched, the higher the temperature in the sauna room.

The best way to find your ideal temperature is to first turn the thermostat to maximum and let the temperature rise to the desired temperature. Subsequently, turn the thermostat knob slowly counter-clockwise until you hear a gentle clicking sound. If you want to re-adjust the temperature, turn the thermostat gradually until the temperature is ideal. The thermostat has an integrated temperature high limit with a reset button next to the top right of the thermostat knob.

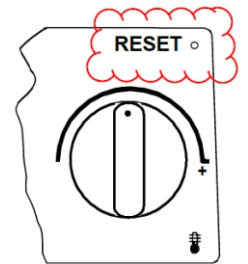

The thermostat will not operate correctly if the stones are piled too densely or they are too small.

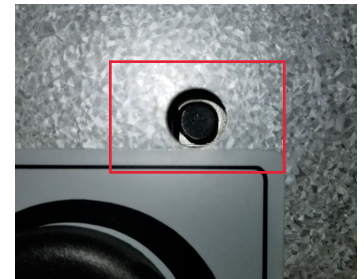
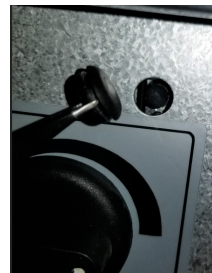

remove rubber plug
press reset

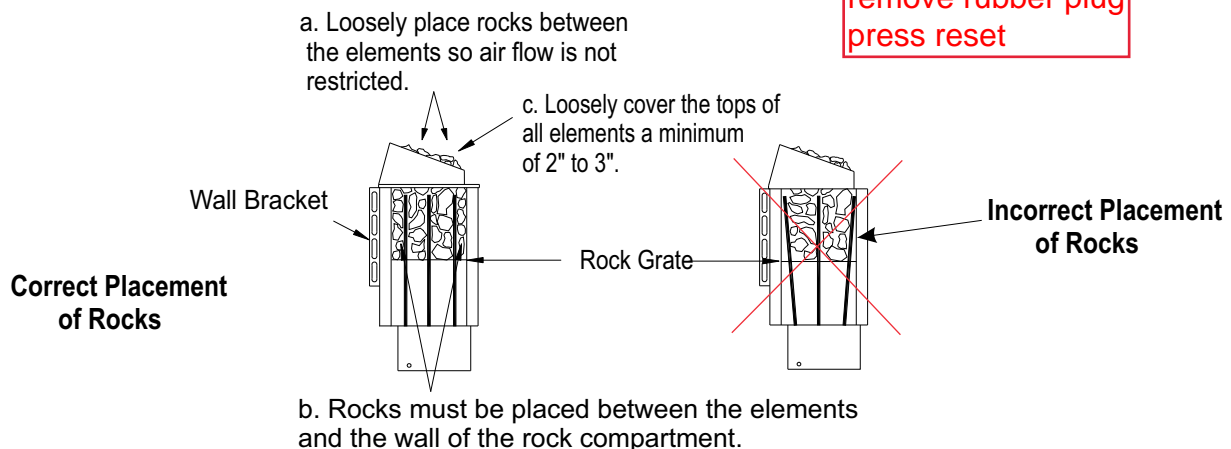

1. Put smaller rocks in first around the outer perimeter of the heating chamber.
2. Completely fill all four sections (front, 2 center sections between elements, and back).
3. In the outer sections, use smaller rocks placed more tightly (see note b).
4. Place rocks loosely in the center 2 sections (see note a).
5. Be sure rocks completely cover the elements (see note c).
6. Loosely cover the tops of all elements a minimum of 2" to 3".



"CUP" SERIES SAUNA HEATERS MODELS 3.0, 4.5, 6.0, 8.0, 9.0 (With built-in controls) (Model #'s 1712-30-171809, 1712-45-171809, 1712-60-171809, 1712-80-171809, 1712-90-171809)

Read all instructions carefully before installation. Please leave all instructions and warranty with the owner.

WARNING

Prolonged exposure to elevated temperatures is capable of inducing hyperthermia. Hyperthermia occurs when the internal temperature of the body reaches several degrees above the normal body temperature of 98.6°F. The symptoms of hyperthermia include an increase in the normal temperature of the body, dizziness, lethargy, drowsiness, and fainting. The effects of the hyperthermia include failure to perceive heat, failure to recognize the need to exit the room, unawareness of impending hazard, fetal damage in pregnant women, physical inability to exit the room and unconsciousness.

WARNING

The use of alcohol, drugs, or medication is capable of greatly increasing the risk of fatal hyperthermia.

SECTION 1: GENERAL INFORMATION

These heaters are built with splash proof construction, the conducting parts are protected against water. All wiring must be performed in accordance with local codes. See Diagram 5 for wire and room size requirements.

WARNING

Do not take a sauna if using alcohol, drugs or medications.

Pregnant women or persons with poor health should consult their physician before using any sauna.

Caution fire hazard: Do not use the sauna room for drying clothes, bathing suits, etc. Do not hang towels above heater or place any object other than the rocks supplied on the heater. If any darkening of the wall around the heater is noticed discontinue sauna use immediately.

Inspect sauna regularly for required maintenance to heater, control and benches. Replace wood surfaces which show any signs of deterioration.

The heater gets extremely hot during operation and should not be touched or burns may result.

Minors should be adequately supervised whenever near a hot or warming sauna.



INSTALLATION AND OPERATING INSTRUCTIONS

DIAGRAM 1

MOUNTING BRACKET LOCATION AND TO MINIMUM DISTANCE TO COMBUSTIBLE MATERIAL

(1" = 25.4 mm)

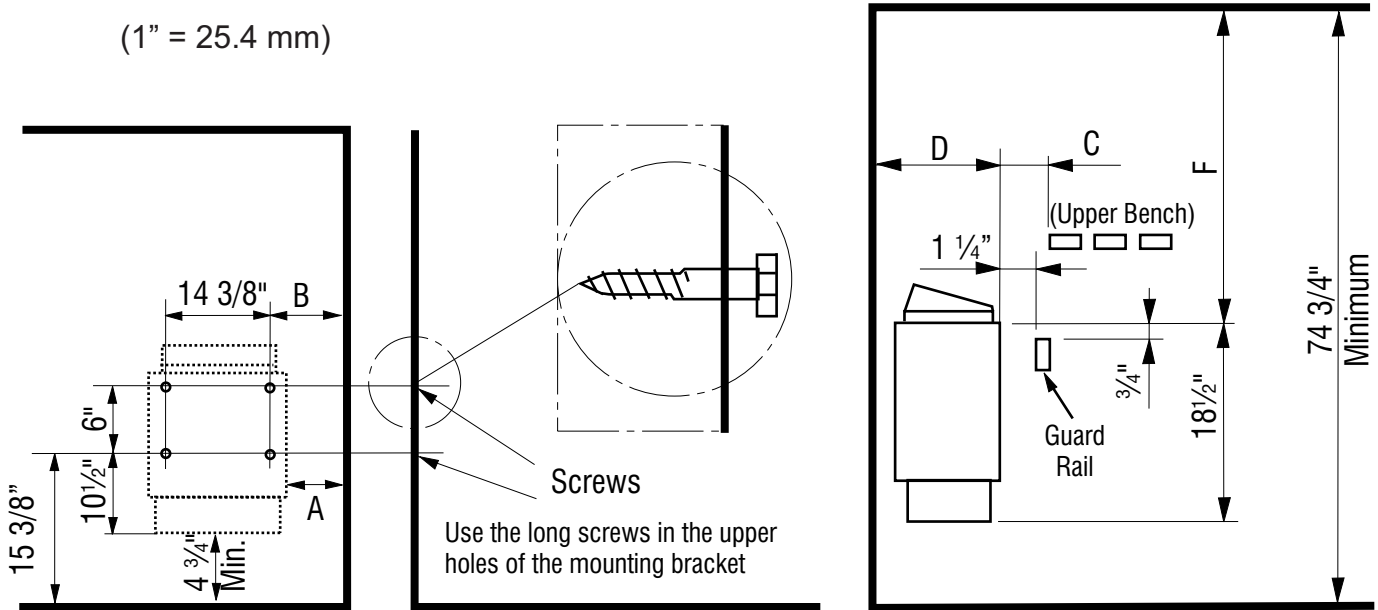

Recheck your distances from the heater to combustible materials to be sure you have the proper minimum distances.



OBSERVING MINIMUM DISTANCES IS REQUIRED TO REDUCE FIRE HAZARD

HEATER	MINIMUM				
	"A" DISTANCE	"B" DISTANCE	"C" DISTANCE	"D" DISTANCE	"F" DISTANCE
CUP 30	1 3/16"	2"	2.0"	10 3/4"	47 1/4"
CUP 45	2.0"	2 3/4"	3 1/8"	10 3/4"	47 1/4"
CUP 60	2 3/4"	3 1/2"	4.0"	10 3/4"	49 1/4"
CUP 80	4.0"	4 3/4"	6.0"	11 1/2"	49 1/4"
CUP 90	4.0"	4 3/4"	7 7/8"	11 1/2"	49 1/4"

DIAGRAM 2

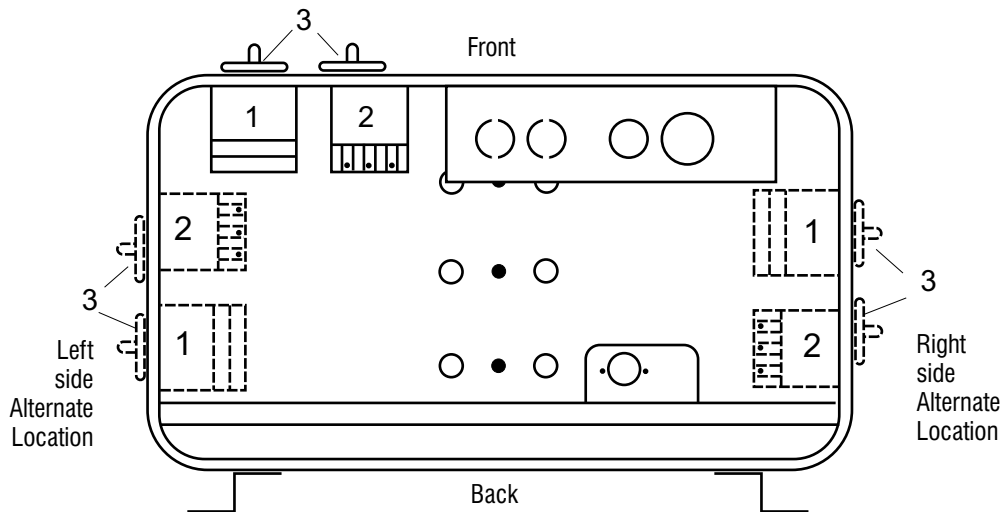

- 1. Timer
- 2. Thermostat/High Limit

- 3. Knobs for the thermostat and the timer.

SECTION 2: MOUNTING OF SAUNA HEATER

For ease of operation, the heater controls may be mounted on the front or either side. If the controls are relocated, this should be done before mounting the heater to the wall.

MOVING THE CONTROLS Lay the heater on its back: remove the control knobs by pulling them straight off (See Item 1 on Diagram 3). Remove the bottom cover by sliding it towards the back of the heater. Remove the round plastic covers from the right or left side of the heater which is the desired new location for the controls. (See Item 2 on Diagram 3)

Remove the screws mounting the controls then carefully move the controls to their new position. (See Diagram 2) Reassemble in the reverse order using the original hardware. Ensure that no wires are pulled loose, pinched, kinked, pulled tight or otherwise damaged. Use the plastic label plates to cover the unused control mounting positions.

HANGING THE HEATER Using the template provided, drill four 9/64" holes to fasten the heater to the wall. Install two 1/4" x 1 1/2" hex head lag screws and two washers on each screw (supplied with the heater) into the upper two holes. Tighten these screws until their heads are about 1/8" from the wall surface. The screws must be threaded through the wall into a framing member or backing board to support the heater weight. Hang the heater on the two upper screws.

Locate the two 1/4" x 1" hex head lag screws (supplied with the heater) then install them into the two lower mounting holes. Tighten to lock the heater in place.

See Diagram 1 & 2 for the heater location details and the necessary clearances to combustible materials.

SECTION 3: PLACING OF ROCKS (SEE DIAGRAM #10)

The rocks supplied with the heater have been chosen to provide the best heater performance. Use of any other type of rock may void the heaters warranty. Never operate the heater without rocks in place!

Rinse the rocks with water before placing in the heater. Carefully place the rocks loosely so that the air can circulate through the heater. Packing the rocks too tightly may cause the heater high limit switch to trip. The rocks must fully cover the heating elements.

WARNING

Fire sprinkler systems used inside any sauna room should be properly rated for sauna room temperatures.

Do not pour chlorinated pool or spa water on heater. Excessive water use on heater may cause damage and void warranty.

Electric Shock Hazard - High voltage exists within this equipment. There are no user serviceable parts in this equipment. All installation and service to this equipment should be performed by qualified licensed personnel in accordance with local and national codes.

Do not construct sauna room so as to restrict air flow through the bottom of the heater.

Packing the rocks too tightly may cause the heater high limit switch to trip.

DIAGRAM 3

MOVING THE CONTROLS

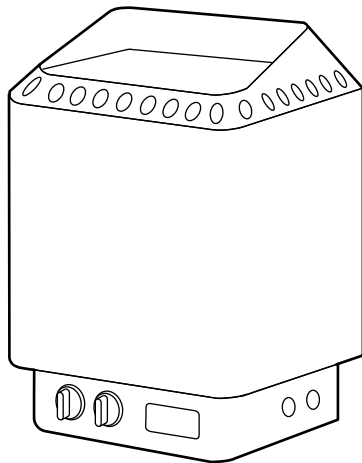

- 2.
1. Remove knobs.
2. Plastic covers.

DIAGRAM 4

THREE HOUR HEATING ZONE AND 9 HOUR DELAY TIMER
 This area from "OFF" to 3 is the "Heat Zone". This is the only time the heater is on.

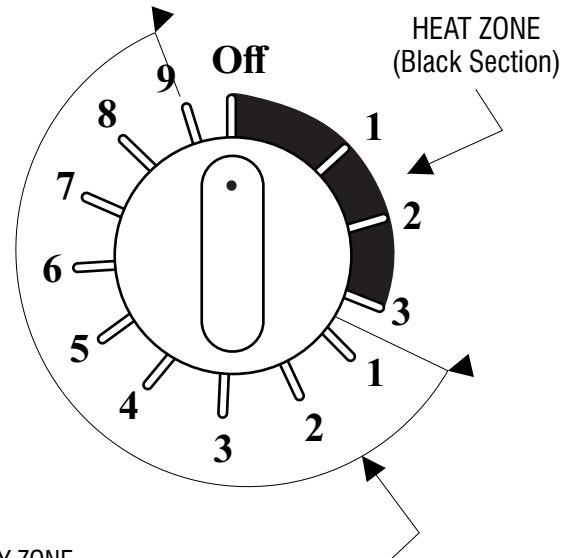

DELAY ZONE
 This area from "1" to "9" after the "Heat Zone" is the delay zone. The heater can have a delayed start to come on up to nine hours later. The heater will not heat in this area.

DIAGRAM 5

HEATER MODEL / Product Number	MINIMUM ROOM		MAXIMUM ROOM Volume Cu.Ft.	PHASE	KW	VAC	AMPS	WIRE SIZE *
	Wall Height	Volume Cu.Ft.						
CUP 30 1712-30-171809	74 3/4"	71	140	1	3.0	230	13.0	12-2 W/G
				1	3.2	240	13.3	12-2 W/G
CUP 45 1712-45-171809	74 3/4"	105	225	1	4.0	230	17.4	10-2 W/G
				1	4.4	240	18.3	10-2 W/G
CUP 60 1712-60-171809	74 3/4"	175	320	1	5.5	230	23.9	10-2 W/G
				1	6.0	240	25.0	10-2 W/G
CUP 80 1712-80-171809	74 3/4"	280	460	1	7.3	230	31.7	8-2 W/G
				1	8.0	240	33.3	8-2 W/G
CUP 90 1712-90-171809	74 3/4"	320	495	1	8.3	230	36.1	8-2 W/G
				1	9.1	240	37.9	8-2 W/G

* Breaker and wire size is recommendation only. Confirm with your licensed electrician.

Note: Heating elements do not change for voltage changes. The heater output will change based on the voltage applied to heater. Most North American homes are 240 volt.

SECTION 4: ELECTRICAL HOOK-UP

Electrical installation must be made by a licensed electrician in accordance with the National Electrical Code and local regulations.

Remove the electrical cover on the bottom front right corner of the heater. Route the feed wires through the holes provided in the bottom of the heater and connect the wires under the screw terminals. To determine the correct wire size, refer to Diagram 5. Use copper supply wire only, suitable for minimum 90 degrees C. The heater must be grounded! See Diagram 6 for proper connections.

SECTION 5: HEATER SCREEN (GUARD RAIL)

Install a wooden heater guard to prevent the sauna bather from accidentally touching the sauna heater. Install the heater guard rail with the height clearances and dimensions shown in Diagram 8.

SECTION 6: OPERATION

The heater is provided with a thermostat to adjust the sauna temperature and a timer to control when the bath starts and stops. For health and fire safety, never attempt to alter or bypass the timer or thermostat.

SETTING THE TEMPERATURE The temperature can be adjusted by turning the thermostat knob. To raise the temperature, turn the knob clockwise; to lower the temperature, turn the knob counter-clockwise.

SETTING THE TIME If you want the heater to begin heating immediately, turn the dial clockwise into the black "Heating Zone" of 1 - 3. If knob is pointing to 2 it will heat for two hours. If it is point to 3 in the black zone it will heat for 3 hours.

The heater is a 12 hour movement. 3 hours are heating time and 9 hours are delay before the heat turns on.

If you set the timer dial in the "1 to 9" delay zone, after the heat zone, the heater will delay the amount of time before turning on.

For example, if the timer is turned to 6 in the delay zone. Six hours from the time of setting the heater will turn on, it will heat for three hours and then turn itself off.

WARNING

Do not locate benches over heater. Minimum clearance of ceiling above heater 44".

Minimum clearance from heater to wooden surfaces (benches, side walls, heater fence etc.) 2 inches. Mounting brackets supplied. Provides proper clearance from wall behind heater.

Use only copper wire of the size and type indicated in the Heater Specification Chart and the temperature rating indicated on the heater junction box.

All heaters and controls must be grounded per NEC to prevent electrical shock in case of unit failure.

Electrical outlets or receptacle must not be installed in a sauna room.

A guardrail or fence is required around the heater to prevent burns from accidental contact.

DIAGRAM 6

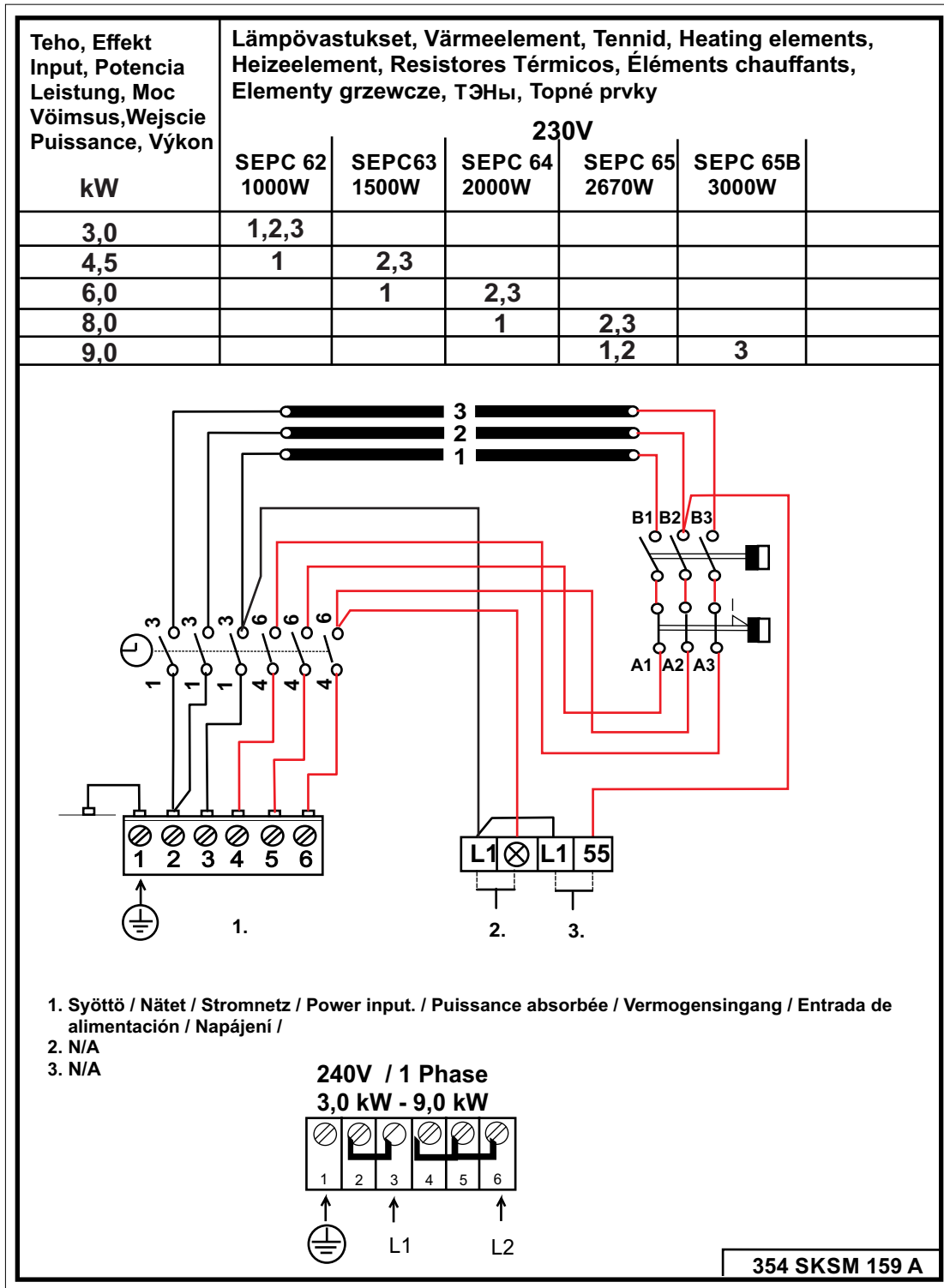

See Diagram 5 for supply connections copper wire size

SECTION 7: HIGH LIMIT CONTROL (RESET BUTTON)

The sauna heater has a built-in high limit control, which automatically turns off the heater if the temperature inside in the sauna room rises to an abnormally high level. The reset button can be accessed next to thermostat.

To restart the heater, let the heater cool and turn the timer down to zero (off), then push the reset button on the bottom of the heater. See Item 2 on Diagram 2 and see graphic below.

If the high limit continually shuts off the heater, refer to the "Troubleshooting" Section.

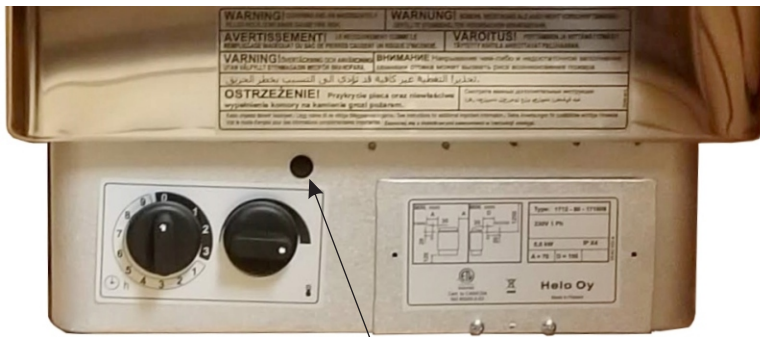

High Limit Reset Button

SECTION 8: HOW TO TAKE A SAUNA

- When taking a sauna, allow time to relax completely.
- Remove clothing and jewelry...if required, wear a towel loosely.
- After 10 minutes or when perspiration begins, leave sauna and relax in dressing area...follow with a cool shower.
- Cooling time should equal time spent in sauna. Enter sauna room again and stay 5 or 10 minutes.
- Repeat the cycle 2 or 3 times; end with a brisk shower...rinse in cool water.
- Dress when completely dry and perspiration has stopped.
- Some sauna bathers enjoy the soothing effect of steam by splashing water on the heated sauna rocks. Use only one dipper full (approx. 1/2 cup) at a time and take care to keep clear of the steam as it rises off the rocks.
- Do not smoke, exercise or drink alcoholic beverages in the sauna room.
- Do not pour chlorinated pool or spa water on the heater or corrosion damage may result.



Shower



Sauna (10 - 15 min.)



Shower or swim



Rest (10 - 15 min.)

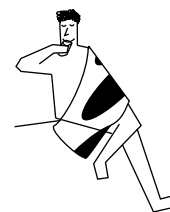

Relax with juice or water

You liked it?
Do it once again and
you will feel great.

DIAGRAM 7

TYPICAL PRE-CUT WALL CONSTRUCTION

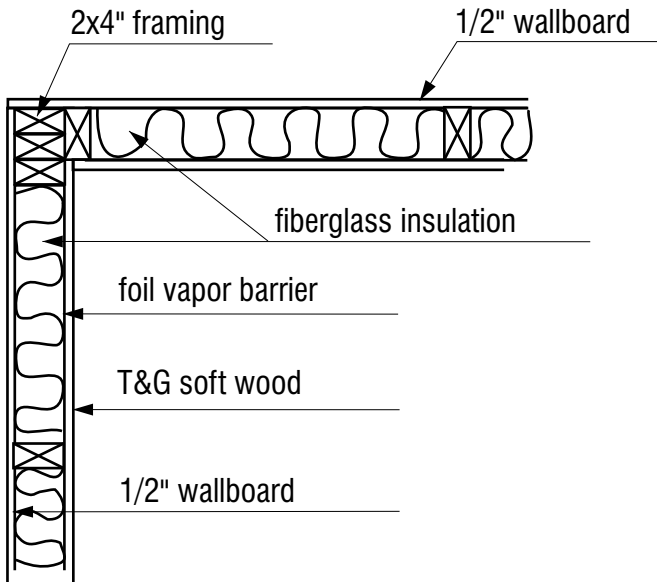

DIAGRAM 8

HEATER SCREEN (GUARD RAIL)

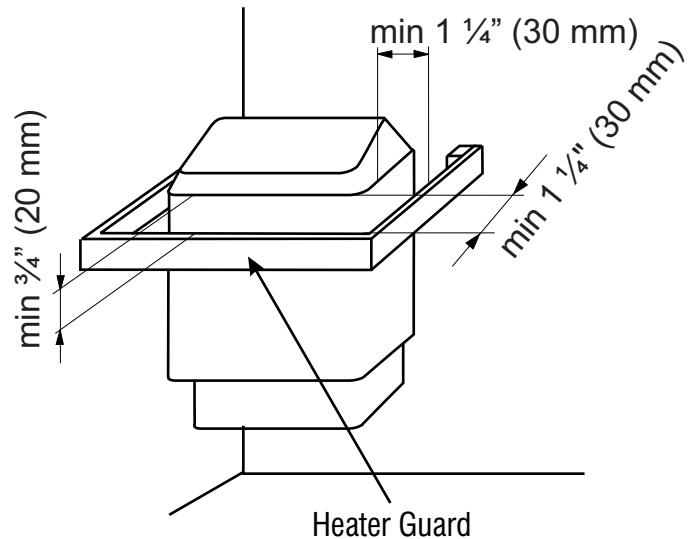

DIAGRAM 9

VENTILATION

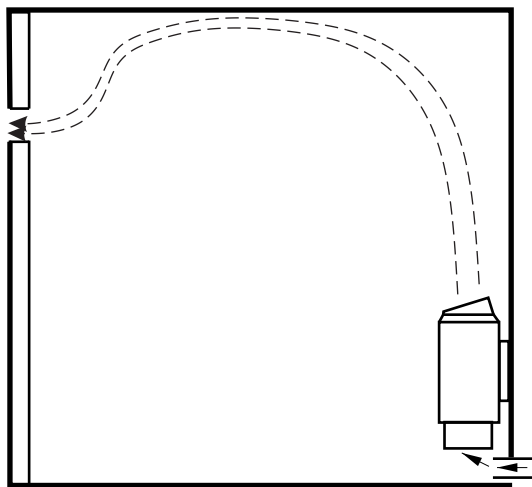
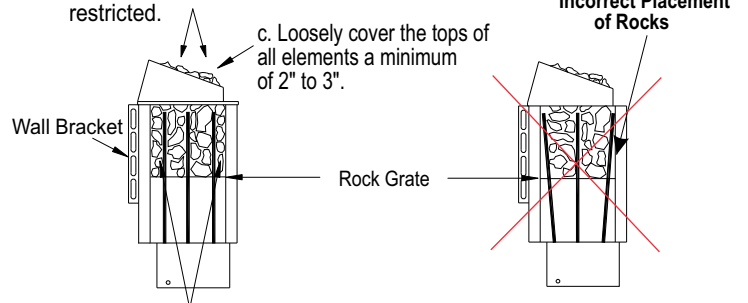

DIAGRAM 10

Correct Placement of Rocks

- a. Loosely place rocks between the elements so air flow is not restricted.

- c. Loosely cover the tops of all elements a minimum of 2" to 3".



- b. Rocks must be placed between the elements and the wall of the rock compartment.

1. Put smaller rocks in first around the outer perimeter of the heating chamber.
2. Completely fill all four sections (front, 2 center sections between elements, and back).
3. In the outer sections, use smaller rocks placed more tightly (see note b).
4. Place rocks loosely in the center 2 sections (see note a).
5. Be sure rocks completely cover the elements (see note c).
6. Loosely cover the tops of all elements a minimum of 2" to 3".

SECTION 9: WARNING PLACARDS

Intentionally Left Blank

SECTION 10: ROOM CONSTRUCTION

For safety and reliability, the following rules must be addressed.

- No permanent locking or latch system is to be used on the sauna door. • Acceptable door fittings are: magnetic catches, friction catches, spring or gravity loaded closures. The door must always open outwards.
- No shower may be installed in a sauna room.
- No electrical receptacle shall be installed inside the sauna room.
- The heater should not be operated without its container properly filled with rocks and the rock guard in place.
- If an intercom speaker is installed, it should be away from the heater and as close to the floor as possible.
- Always mount the heater according to these installation instructions.

WARNING

For safety purpose sauna door must open out and not lock.

Never use a wood stain, seal or preservative on the inside of your sauna room.

Light fixtures get very hot during operation. Locate light fixture where it will not be a burn hazard.

DIAGRAM 11: ROOM TEMPERATURES

Notes:

Temperatures vary in a sauna room by height and distance from heater.

Ventilation will help reduce it but will not eliminate temperature variations.

The hottest part of the room is always at the ceiling directly above the sauna heater and should not exceed 194°F (90°C).

Air temperature will be 15°F (9°C) to 25°F (14°C) lower on the opposite side of the room from the heater close to the ceiling.

The temperatures in the elevated view are general numbers. Each sauna room is different due to construction variations and ventilation.

Typical Ceiling Height

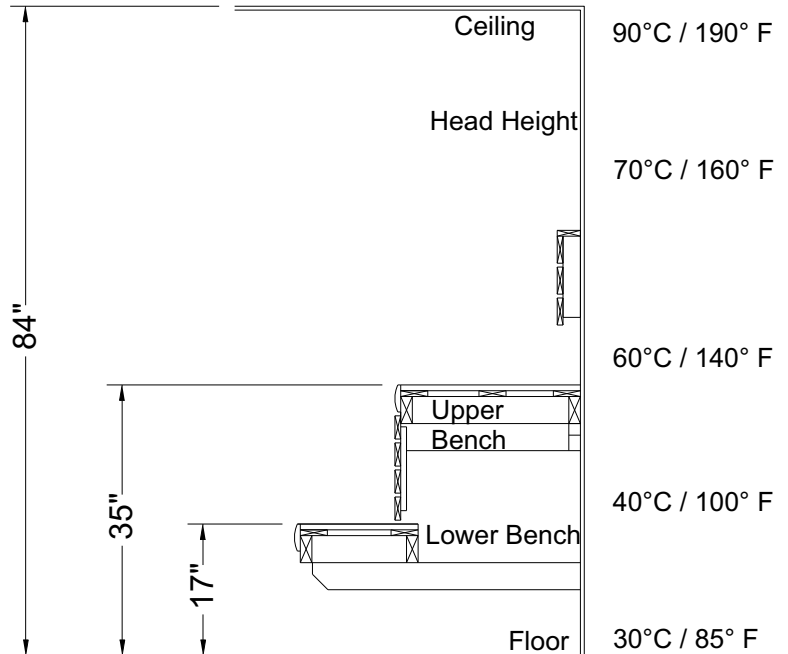

Non-Typical Ceiling Height

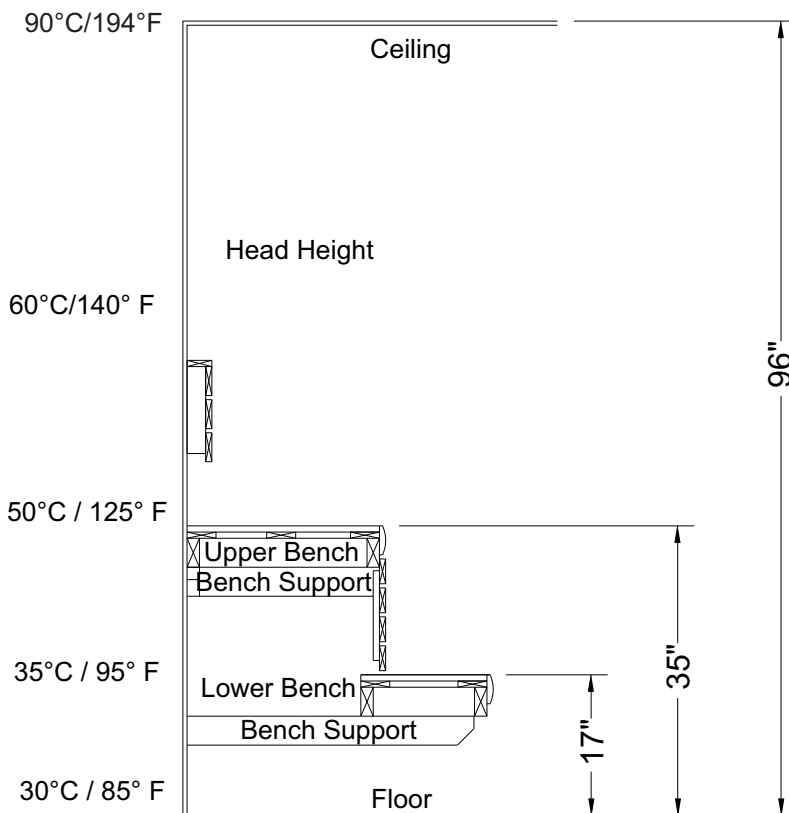

SECTION 11: VENTILATION

VENTILATION In a sauna, the air should be changed about 6 times an hour. This can be achieved by making a vent opening (fresh air inlet) in the sauna wall directly below the heater. The air outlet must opposite side of the room high on the wall. See Diagram 9.

It is recommended that ventilation openings meet the following formulas. The minimum opening should be determined using one of the following formulas:

$$\text{For } R < 31, \quad V \geq 9.3$$

$$\text{For } R \geq 31, \quad V \geq 0.3R$$

where R = the floor area of the room in square feet and

V = the minimum vent size in square inches

SECTION 12: MAINTENANCE

The sauna, like a bathroom, should be kept clean and odor free.

Towels or mats should always be used on benches and floor as perspiration otherwise penetrates the soft wood.

Air out the sauna often by keeping the door and vents open when the sauna is not in use. Saunas that are in daily use should be washed down at least once a week to keep them clean and the air fresh. Duckboard should be removed from the sauna, the sauna floor mopped and dried in a conventional manner, and the duckboard thoroughly scrubbed and dried before returning to the sauna room. The sauna heater should be wiped down occasionally with a damp cloth to remove lint and dust. The rocks should be removed once a year for cleaning and small or crumbled rocks replaced.

To clean and remove perspiration stains, use soap or detergent in warm water, best applied with a scrub brush. Badly soiled surfaces may require sanding. Sand paper wrapped around a wooden block works well.

Benches and supporting structure must be inspected annually for potential deterioration due to age, dry rot or abuse. Any boards with signs of deteriorations should be replaced immediately to avoid possible injury.

SECTION 13: TROUBLESHOOTING

No Heat - Check timer, refer to Section 6 and Diagram 4 about timer operation.

No Heat - Press (reset) the high limit switch on the bottom of heater next to thermostat (Section 7).

Low Heat or Slow Heat Time or High Limit Tripping - Check rock placement, they will break down over time and reduce the air flow in the heater. Refer to Diagram 10 for proper rock installation. Discard all rocks under the size of 2" pieces.