

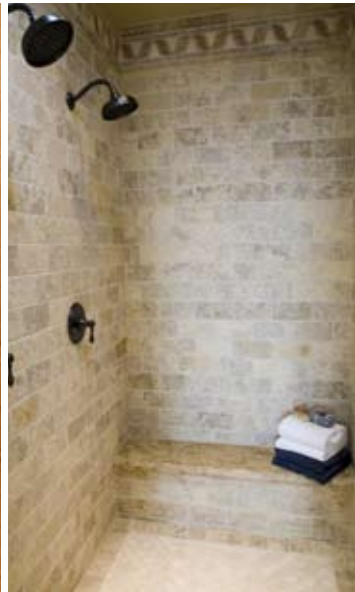

Innovative Tile and Stone  
Installation Systems

# Tiled Steam Room and Steam Shower Technical Design Manual



©2009 LATICRETE International, Inc. All rights reserved. No part of this publication (except for previously published articles and industry references) may be reproduced or transmitted in any form or by any means, electronic or mechanical, without the written permission of LATICRETE International, Inc.

The information and recommendations contained herein are based on the experience of the author and LATICRETE International, Inc. While we believe the information presented in these documents to be correct, LATICRETE International, Inc. and its employees assume no responsibility for its accuracy or for the opinions expressed herein. The information contained in this publication should not be used or relied upon for any specific application or project without competent examination by qualified professionals and verification of its accuracy, suitability, and applicability. Users of information from this publication assume all liability arising from such use.

# **TILED STEAM ROOM AND STEAM SHOWER TECHNICAL DESIGN MANUAL**

**LATICRETE Technical Services**

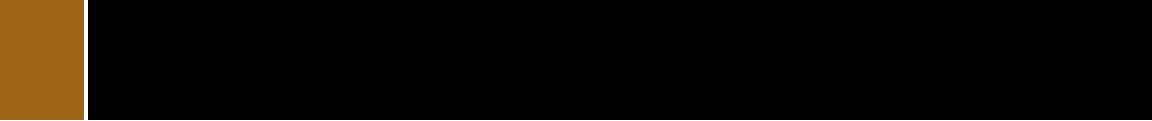

**PREFACE ..... 5**

**SECTION 1: INTRODUCTION**

1.1 Steam Room Facts .....9

1.2 Tile Installations in Steam Rooms – Materials and Methods .....9

1.3 Summary ..... 13

**SECTION 2: SPECIFICATION FOR STEAM ROOM – FULL MORTAR BED METHOD**

Detail ES-SR613..... 16

General Information ..... 17

Products ..... 24

Execution Statement..... 27

Health and Safety..... 34

**SECTION 3: SPECIFICATION FOR STEAM ROOM – THIN BED METHOD**

Detail ES-SR614..... 36

General Information ..... 37

Products ..... 43

Execution Statement..... 46

Health and Safety..... 54

**SECTION 4: STEAM ROOM DETAIL DRAWINGS ..... 56**

4.1 ES-SR613 – Steam Room – Full Mortar Bed with Waterproofing ..... 56

4.2 ES-SR614 – Steam Room – Thin Bed Method with Waterproofing..... 57

4.3 ES-SR614B – Steam Room – Cement Backer Board – Vapor Barrier Placement..... 58

4.4 ES-P605 – Pool/Fountain/Steam Room Penetration..... 59

4.5 WP-SR302 – Steam Room Drain Detail ..... 60

**SECTION 5: MAINTENANCE AND PROTECTION..... 62**

5.1 Quality Assurance..... 62

5.2 Preventative and Corrective Maintenance ..... 63

5.3 Protection and Sealing..... 64

5.4 Case Study – Full Mortar Bed Steam Room ..... 65

**SECTION 6: APPENDIX ..... 78**

6.1 Steam Room Frequently Asked Questions ..... 78

6.2 Resource Guide – Trade Organizations and Technical Resources ..... 80

6.3 Glossary..... 82

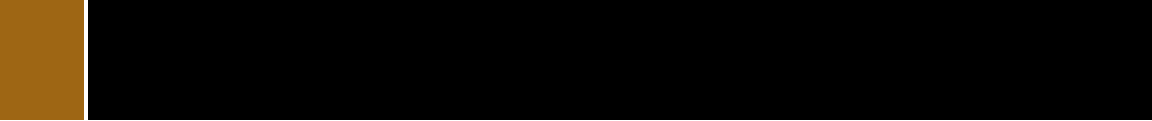

LATICRETE International, Inc., a world leader in the manufacturing of ceramic tile and stone installation systems, has long recognized the need for a technical design manual to provide guidelines and recommendations for the design, specification and installation of tile and stone in steam room/steam shower applications. Improved technology in steam room construction and equipment has made steam rooms and steam showers readily available to anyone. In keeping with our position as an industry leader, LATICRETE International is publishing this **Tiled Steam Room and Steam Shower Technical Design Manual** to provide information and guidelines to architects, design professionals, construction professionals, tile installation professionals, and the tile and stone distribution industry. It is the goal of this manual to provide the necessary information to help ensure a proper and long-lasting tile installation in a steam room or steam shower environment.

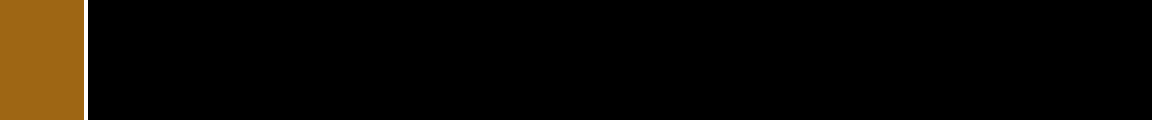



# Section 1: Introduction





### 1.1 Steam Room Facts

Who wouldn't like to have a steam bath or steam shower in their own home? Steam provides an invigorating way to maintain or restore physical and mental health. Sitting in a steam room environment can help the body to burn calories, improve circulation, relax muscles, flush toxins from the body, cleanse pores, relieve stress, and help induce more relaxing sleep. All of this in just twenty minutes a day!

The fact is; steam rooms and steam showers are becoming more and more common in home environments. They are no longer just for health clubs or the very wealthy; now anybody can own their own steam room. Steam room and steam showers are fairly often included in new home construction, rather than a standard shower. While there are many benefits to owning and using a steam room or steam shower there are also some basic principles that must be kept in mind when designing, installing and using these units:

1. Prevent steam from escaping.
2. Collect any condensed water and allow it to drain properly.
3. Keep water from dripping on the steam room occupants.

Steam generation units create a great deal of moisture; this moisture initially takes the form of water vapor (steam). This water vapor is highly penetrative and any room not properly prepared may be exposed to damage caused by excessive moisture. Proper measures must be taken to prevent moisture transgression into or through walls, ceiling and floor.

These preventive measures include a properly placed, suitable vapor barrier and/or an acceptable waterproofing membrane. LATICRETE International, Inc. always recommends using both a vapor barrier, placed on the framing or on the concrete/concrete masonry units prior to further construction, and LATICRETE® Hydro Ban™ or LATICRETE

9235 Waterproofing Membrane. Tile is the perfect finish for a steam room application and choosing the right tile is important. For best results, the tile should be impervious (i.e. porcelain) or have a glazed surface to help limit the amount of moisture and moisture vapor that makes its way into the system.

An acceptable vapor barrier can be a vital component of any steam room and, when properly installed, can prevent moisture from getting into wall and ceiling cavities. When hot, moist air comes in contact with cooler surfaces (at or below dew point) it condenses and turns back into water. If the dew point temperature is within the wall cavity then the moisture will either build up within the wall or show up in areas where water is not supposed to be found. This can lead to structural damage, mold, water problems, poor indoor air quality, and more. In order to function properly it is critical that this vapor barrier laps into the shower pan (another critical component of a steam room installation).

### 1.2 Tile Installations in Steam Room and Shower Applications Materials and Methods

Let's look at two typical steam room constructs:

1. The first design incorporates steel or wood framing and a concrete, slab-on-grade sub-floor. The ceiling should be sloped at least 2" minimum per foot (50 mm per 300 mm) to prevent water from dripping on steam room occupants (per Tile Council of North America recommendations). The floor should be pre-pitched (prior to the installation of the shower pan liner) at the rate of 1/4" per foot (6 mm per 300 mm) to make sure that water flows toward the drain. Keep in mind that a shower pan is required in all steam room/steam shower installations!

## Section 1: Introduction

The installation begins with the proper choice and placement of a two-part clamping-ring-style drain with weepers as per ASMEA112.6.3. Place tile spacers or gravel around weep holes, as detailed by the design professional, to prevent mortar from clogging the weep holes and should be installed by a qualified plumber in accord with International Residential Code (IRC) P2709.4. The pipes and drain should be properly supported to prevent problems in the future. A suitable primary shower pan liner, complying with ASTM D 4068, D 4551 or other International Code Council (ICC) and International Association of Plumbing and Mechanical Officers (IAPMO) approved material, would then be installed to tie into the bottom flange of the drain (without blocking the weep holes). The liner must be turned up the walls to a point at least 3" (75 mm) above the top of the curb or 6" (150 mm) above the floor in steam rooms or steam showers without curbs. The shower pan must be properly formed and fastened to prevent problems. Check with local building code to help determine what shower pan liner is acceptable in your area. This pan will act as your vapor barrier on the floor. Curbs must be sloped to drain back into the steam room for condensation runoff. Perform a flood test to determine integrity of the pan liner and make repairs as necessary before proceeding.

After the shower pan liner is in place, install the vapor barrier directly onto the side of the wall and ceiling framing that will be exposed to the steam room. The vapor barrier should be 4 – 6 mil thick polyethylene (cross laminated virgin polyethylene is excellent) and, if possible, should be one piece that can fit into the entire area. Fasten the vapor barrier to the studs with corrosion-resistant fasteners. A spot of LATICRETE® Latasil™ (100% silicone sealant) onto the fasteners will help prevent moisture penetration through the fastener holes. Make sure that the vapor barrier is properly formed and is tight to the studs of the walls and ceiling. Yes – the vapor barrier

must be installed onto the ceiling as well as the walls because steam can certainly escape through the ceiling. It is imperative that this vapor barrier be placed so that it laps into the shower pan liner! This way any moisture that comes in contact with the vapor barrier will drain into the shower pan and through the weep holes of the drain.

Next, install a 2" (50 mm) thick (minimum) wire-reinforced, mortar bed comprised of LATICRETE 3701 Fortified Mortar Bed; or, LATICRETE 226 Thick Bed Mortar gauged with LATICRETE 3701 Mortar Admix onto the shower floor. The wire-reinforcement should be 2" x 2" (50 mm x 50 mm), 16 gauge, galvanized, welded wire mesh and should be placed at half the depth of the mortar bed. Make sure that the mortar bed maintains the 1/4" per foot (6 mm per 300 mm) slope to drain which was established by the pre-pitch in the sub-floor. After the mortar bed has cured, the installation of the cement backer board on the walls and ceiling can begin.

The addition of a suitable insulation material between the wall and ceiling framing should be done before installation of the cement backer board. Insulation will help keep the heat in the steam room, cool air out, and helps to control the dew point (the temperature where condensation takes place) within the wall. The cement backer board used must be acceptable for steam room use and installed per the board manufacturer's written installation instructions; this includes taping of all board joints. Use LATICRETE 254 Platinum and 2" (50 mm) wide, alkali-resistant fiberglass mesh tape to treat the board joints. Be sure to allow space at the ceiling/wall transition for the insertion of a slip joint to allow for proper expansion/contraction to take place.

Pipes and penetrations through board should be accounted for and space between board and penetration should be kept to a minimum. Allow the mortar used to tape the board joints to harden and then commence with

waterproofing the entire inside area of the steam room with LATICRETE Hydro Ban™ or LATICRETE 9235 Waterproofing Membrane. The entire steam room should be waterproofed, including the ceiling, walls, floor, seat, and any other exposed area; this will help improve the functionality of the vapor barrier and inhibit the passage of most of the moisture through the system. Loop the LATICRETE Hydro Ban or LATICRETE 9235 Waterproofing Membrane into the slip joints to allow for movement in these areas. Any vapor transpiring through the LATICRETE 9235 Waterproofing Membrane should easily be handled by the vapor barrier. For more information on the installation of LATICRETE Hydro Ban or LATICRETE 9235 Waterproofing Membrane, please refer to [www.laticrete.com](http://www.laticrete.com). Make sure that ANY and ALL penetrations are properly waterproofed and sealed tightly with LATICRETE Latasil!

Tile can be installed directly onto the LATICRETE Hydro Ban or LATICRETE 9235 Waterproofing Membrane as soon as it is dry to the touch. LATICRETE 254 Platinum is the thin-set of choice for steam room/steam shower installations. Check with the manufacturer of the tile to make sure that it is compatible in steam room applications.

Once the tiles have set firm, grout the installation with LATICRETE SpectraLOCK® PRO Grout for best performance. Alternative grouting choices would be LATICRETE PermaColor™ Grout<sup>^</sup>. Use LATICRETE Latasil, with LATICRETE 9118 Primer, in slip joints, steam jets, movement joints, around the drain, to seal lighting fixtures, access panels (if present), or at any change of plane. The use of LATICRETE SpectraLOCK PRO Grout will add to the performance of the tile installation because it has an absorption rate of <.5%. It will be necessary to wait for 14 days for LATICRETE PermaColor Grout, and 10 days for LATICRETE SpectraLOCK PRO Grout to cure at 70°F (21°C) before turning on the steam generation unit.

2. The second design involves installation over all other substrates including concrete or masonry walls. Again, the ceiling should be sloped at least 2" minimum per foot (50 mm per 300 mm) to prevent water from dripping on steam room occupants (per Tile Council of North America recommendations). The floor should be pre-pitched (prior to the installation of the shower pan) at the rate of 1/4" per foot (6 mm per 300 mm) to make sure that water flows toward the drain. Also, a shower pan is required in ALL steam room/steam shower installations!

The installation begins with the proper choice and placement of a two-part clamping ring style drains with weepers as per ASME A112.6.3. Place tile spacers or gravel around weep holes, as detailed by the design professional, to prevent mortar from clogging the weep holes, they should be installed by a qualified plumber in accord with IRC P2709.4. The pipes and drain should be properly supported to prevent problems in the future. For this type of steam room construction, LATICRETE Hydro Ban or LATICRETE 9235 Waterproofing Membrane can be used as the primary shower pan liner. A suitable primary shower pan liner material, complying with



## Section 1: Introduction

ASTM D4068, D4551 or other ICC and IAPMO approved material may also be used as the primary shower pan liner. No matter which of the approved materials is used as the shower pan liner, it must be tied into the bottom flange of the drain properly. The liner is applied directly onto the concrete or masonry walls and concrete floor. The liner must be turned up the walls to a point at least 3" (75 mm) above the top of the curb or 6" (150 mm) above the floor in steam rooms or steam showers without curbs. The shower pan must be properly formed and fastened to prevent problems. Check with local building code to help determine what shower pan liner is acceptable in your area. This pan will act as your vapor barrier on the floor. Curbs must be sloped to drain back into the steam room for condensation runoff. Perform a flood test to determine integrity of the pan liner and make repairs as necessary before proceeding. Allow 22 hour cure period at 70°F (21°C) prior to flood testing LATICRETE® Hydro Ban™ a 7 day cure at 70°F (21°C) prior to flood testing LATICRETE 9235 Waterproofing Membrane. For more information on flood testing requirements and procedures, please refer to TDS 169 "Flood Testing Procedures" at [www.laticrete.com](http://www.laticrete.com).

After the shower pan liner is in place, install the vapor barrier directly onto the concrete/masonry walls making sure that the vapor barrier laps into the shower pan liner. The vapor barrier should be 4–6 mil polyethylene (cross laminated virgin polyethylene is excellent) and, if possible, should be one piece that can fit into the entire area. Fasten the vapor barrier to the wall with corrosion resistant fasteners. A spot of LATICRETE Latasil™ (100% silicone) onto the fasteners will help prevent moisture penetration through the fastener holes. Make sure that the vapor barrier is properly formed and is tight to the walls and ceiling. Yes the vapor barrier must be installed onto the ceiling as well as the walls because steam can certainly escape through the ceiling. It is

imperative that this vapor barrier be placed so that it laps into the shower pan liner! This way any moisture that comes in contact with the vapor barrier will drain into the shower pan and through the weep holes of the drain.

Once the vapor barrier has been properly installed, application of the insulation panels can commence. These panels are typically fastened mechanically through to the substrate through the vapor barrier; check with the insulation manufacturer for proper installation instructions for their product in this application. A dab of LATICRETE Latasil can help prevent moisture from getting through the fastener holes. Install galvanized diamond metal lath, complying with ASTM C847, according to the current revision of ANSI A108.1 (1.1 and 1.2). Make sure that no fasteners penetrate the shower pan liner. Pencil rods and tie wires may also be used to secure the metal lath in place.

Apply a mortar bed consisting of LATICRETE 3701 Fortified Mortar Bed; or, LATICRETE 226 Thick Bed Mortar gauged with LATICRETE 3701 Mortar Admix as scratch and leveling coats, in compliance with ANSI A108.1A (1.3 and 1.4) over the wire lath on the walls and ceiling. The scratch and float coats can be installed in lifts up to 5/8" (13 mm) thick and should be floated to be plumb and true.

Next, install a 2" (50 mm) thick (minimum) wire-reinforced, mortar bed comprised of LATICRETE 3701 Fortified Mortar Bed; or, LATICRETE 226 Thick Bed Mortar gauged with LATICRETE 3701 Mortar Admix onto the shower floor. The wire-reinforcement should be 2" x 2" (50 mm x 50 mm), 16 gauge, galvanized, welded wire mesh and should be placed at half the depth of the mortar bed. Make sure that the mortar bed maintains the 1/4" per foot (6 mm per 300 mm) slope to drain which was established by the pre-pitch in the sub-floor.

Allow the floor mortar bed to set until firm and then commence with waterproofing the inside area of the steam room with LATICRETE Hydro Ban or LATICRETE 9235 Waterproofing Membrane. The entire steam room should be waterproofed, including the ceiling, walls, floor, seat, and any other exposed area; this will help improve the functionality of the vapor barrier and inhibit the passage of most of the moisture through the system. Any vapor transpiring through the LATICRETE Hydro Ban or LATICRETE 9235 Waterproofing Membrane should easily be handled by the vapor barrier. Make sure that any and all penetrations and fixtures are properly waterproofed and sealed tightly with LATICRETE Latasil.

Tile can now be installed directly onto the LATICRETE Hydro Ban or LATICRETE 9235 Waterproofing Membrane once it has sufficiently cured. LATICRETE 254 Platinum is the thin-set of choice for steam room/steam shower installations. Check with the manufacturer of the tile to make sure that it is compatible in steam room applications.

Once the tiles have set firm, grout the installation with LATICRETE SpectraLOCK<sup>®†</sup> PRO Grout for best performance. Alternative grouting choices would be LATICRETE PermaColor<sup>™^</sup> Grout<sup>^</sup>. Use LATICRETE Latasil, with LATICRETE 9118 Primer, in slip joints, steam jets, movement joints, around the drain, or at any change in plane. The use of LATICRETE SpectraLOCK PRO Grout will add to the performance of the tile installation because it has an absorption rate of <.5%. It will be necessary to wait for 14 days for LATICRETE PermaColor Grout, and 10 days for LATICRETE SpectraLOCK PRO Grout to cure at 70°F (21°C) before turning on the steam generation unit.

### 1.3 Summary

Expansion joints are generally placed at the wall/floor and wall/ceiling transitions. Larger steam rooms may require additional expansion joints to allow for movement. The project design professional should indicate where these expansion joints are placed. Refer to the Tile Council of North America Handbook for Ceramic Tile Installation EJ-171 for more information and details.

Once the steam room is ready...ENJOY!!

Please refer to the proper execution statement located at the back of this guide for more detailed instructions and details on these steam room installations.

Just keep in mind, it would be beneficial for all concerned to make sure that the steam room construction and installation is done right the first time. Any mistake can lead to structural damage, mold, water infiltration issues, and more.

Repairs can be extensive, and the steam room would be far more costly to repair than to do it right the first time!!

<sup>†</sup> United States Patent No.: 6,881,768 (and other Patents).

<sup>^</sup> United States Patent No.: 6,784,229 B2 (and other Patents.)

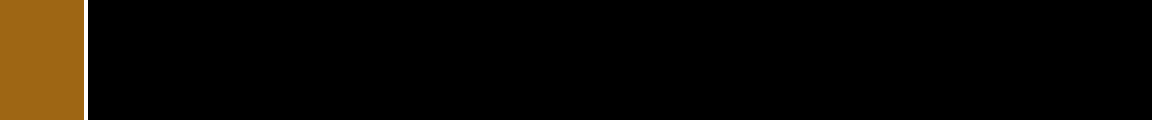



## Section 2: Specification for Steam Room – Full Mortar Bed



**Section 2: Detail ES – SR 613**

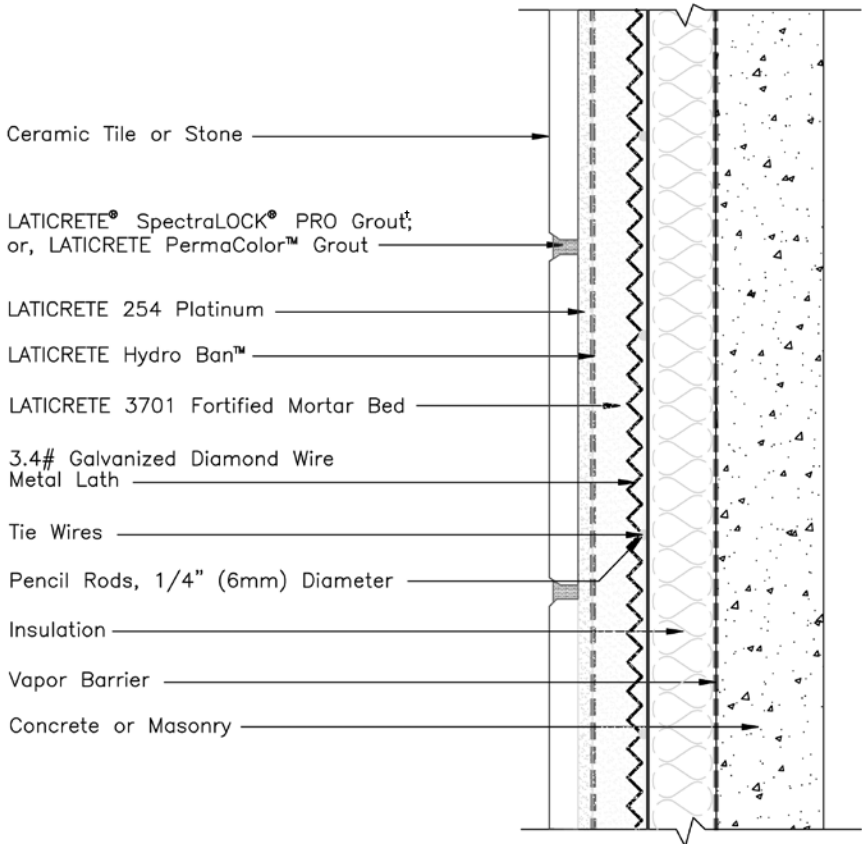

Revision Date: 09/09  
Scale: NTS

**NOTE:** For complete application information and limitations consult related Product Data Sheets and Execution Statements related to this detail and applicable industry standards.

As a professional courtesy, LATICRETE offers technical services free of charge. The user maintains all responsibility for verifying the applicability and suitability of the technical service or information provided.

<sup>†</sup> United States Patent No.: 6881768 (and other Patents).

©2009 LATICRETE INTERNATIONAL, INC. ALL RIGHTS RESERVED. The right to utilize LATICRETE details for commercial purposes is granted exclusively to contractors, architects, quantity surveyors, engineers, and specifications writers. LATICRETE®, LATAPOXY®, SPECTRALOCK® are registered trademarks of LATICRETE International, Inc. U.S. and Foreign Patent and Trademark Offices, Marca Registrada. All other trademarks are property of their respective companies.

## PART 1 – GENERAL

### 1.1 Summary

A. Scope of work – Provide ceramic tile, tile installation materials and accessories as indicated on drawings, as specified herein, and as needed for complete and proper installation.

B. Related Documents – provisions within General and Supplementary General Conditions of the Contract, Division 1 - General Requirements, and the Drawings apply to this Section.

### 1.2 Section Includes

- A. Ceramic wall tile and trim units (glazed)
- B. Ceramic floor tile/mosaics and trim units (glazed or unglazed)
- C. Ceramic tile pavers and trim units (glazed or unglazed)
- D. Quarry tile pavers and trim units (glazed or unglazed)
- E. Porcelain tile
- F. Glass mosaics
- G. Special purpose tile
- H. Decorative thin wall tile
- I. Installation Products; adhesives, mortars, grouts and sealants
- J. Waterproofing membranes for ceramic tile work
- K. Anti-fracture membranes for ceramic tile work
- L. Sound control underlayments
- M. Thresholds, trim, cementitious backer units and other accessories specified herein.

**NOTE TO SPECIFIER:** Edit for applicable procedures and materials.

### 1.3 Products Furnished But Not Installed Under This Section

**NOTE TO SPECIFIER:** Edit for applicable products

### 1.4 Products Installed But Not Furnished Under This Section

**NOTE TO SPECIFIER:** Edit for applicable products.

### 1.5 Environmental Performance Requirements

A. Environmental Performance Criteria: The following criteria are required for products included in this section.

Refer to Division 1 for additional requirements:

1. Products manufactured regionally within a 500 mile radius of the Project site;
2. Adhesive products must meet or exceed the VOC limits of South Coast Air Quality Management District Rule #1168 and Bay Area Resources Board Reg. 8, Rule 51.

### 1.6 Related Sections

- A. Section 03300 Cast-in-Place Concrete (monolithic slab finishing for ceramic tile)
- B. Section 03305 Concrete Curing
- C. Section 03410 Structural Pre-cast Concrete
- D. Section 03532 Concrete Floor Topping
- E. Section 04200 Unit Masonry (CMU wall substrates)
- F. Section 04300 Stone
- G. Section 06100 Rough Carpentry (plywood sub-floors)
- H. Section 07110 Membrane Waterproofing
- I. Section 07920 Elastomeric Joint Sealants
- J. Section 09250 Gypsum Board Assemblies
- K. Section 09385 Stone Tile
- L. Section 10800 Washroom Accessories
- M. Section 15440 Plumbing Fixtures

**NOTE TO SPECIFIER:** Above are examples of typical broad scope and narrow scope sections related to ceramic tile installation. Edit for applicable related sections.

### 1.7 Allowances

**NOTE TO SPECIFIER:** Edit for detail of applicable ALLOWANCES; coordinate with Section 01020 Allowances. Allowances in the form of unit pricing are sometimes used when the scope of the tile work at time of bid is undetermined.

### 1.8 Alternates

**NOTE TO SPECIFIER:** Edit for applicable ALTERNATES. Alternates may be used to evaluate varying levels of performance of setting systems or to assist in the selection of the tile by economy.

### 1.9 Reference Standards

- A. American Iron and Steel Institute (AISI) Specification for the Design of Cold-Formed Steel Structural Members
- B. American National Standards Institute (ANSI) A137.1 American National Standard Specifications For Ceramic Tile
- C. American National Standards Institute (ANSI) A108.01 – A108.17 American National Standard Specifications For The Installation Of Ceramic Tile
- D. American National Standards Institute (ANSI) A118.1 – A118.12 American National Standard Specifications For The Installation Of Ceramic Tile
- E. American National Standards Institute (ANSI) A136.1 American National Standard Specifications For The Installation Of Ceramic Tile
- F. American Plywood Association (APA) Y510T Plywood Design Specifications
- G. American Society For Testing And Materials (ASTM) A82 Standard Specification for Steel Wire, Plain, for Concrete Reinforcement
- H. American Society For Testing And Materials (ASTM) A185 Standard Specification for Steel Welded Wire Fabric, Plain, for Concrete Reinforcement
- I. American Society For Testing And Materials (ASTM) C33 Standard Specification for Concrete Aggregate
- J. American Society For Testing And Materials (ASTM) C36 Standard Specification for Gypsum Wallboard
- K. American Society For Testing And Materials (ASTM) C109 Standard Test Method for Compressive Strength of Hydraulic Cement Mortars (Using 2" or 50 mm Cube Specimens)
- L. American Society For Testing And Materials (ASTM) C144 Standard Specification for Aggregate for Masonry Mortar
- M. American Society For Testing And Materials (ASTM) C150 Standard Specification for Portland Cement
- N. American Society For Testing And Materials (ASTM) C171 Standard Specification for Sheet Materials for Curing Concrete
- O. American Society For Testing And Materials (ASTM) C241 Standard Test Method for Abrasion Resistance of Stone Subjected to Foot Traffic
- P. American Society For Testing And Materials (ASTM) C267 Standard Test Method for Chemical Resistance of Mortars, Grouts, and Monolithic Surfacing
- Q. American Society For Testing And Materials (ASTM) C482 Standard Test Method for Bond Strength of Ceramic Tile to Portland Cement
- R. American Society For Testing And Materials (ASTM) C503 Standard Specification for Marble Dimension Stone (Exterior)
- S. American Society For Testing And Materials (ASTM) C531 Standard Test Method for Linear Shrinkage and Coefficient of Thermal Expansion of Chemical-Resistant Mortars, Grouts, Monolithic Surfacing and Polymer Concretes
- T. American Society For Testing And Materials (ASTM) C627 Standard Test Method for Evaluating Ceramic Floor Tile Installation Systems Using the Robinson-Type Floor Tester
- U. American Society For Testing And Materials (ASTM) C794 Standard Test Method for Adhesion-in-Peel of Elastomeric Joint Sealants
- V. American Society For Testing And Materials (ASTM) C847 Standard Specification for Metal Lath
- W. American Society For Testing And Materials (ASTM) C905 Standard Test Method for Apparent Density of Chemical-Resistant Mortars, Grouts, and Monolithic Surfacing

- X. American Society For Testing And Materials (ASTM) C920 Standard Specification for Elastomeric Joint Sealants
- Y. American Society For Testing And Materials (ASTM) C955 Standard Specification for Load Bearing (Transverse and Axial) Steel Studs, Runners (Tracks), and Bracing or Bridging for Screw Application of Gypsum Board and Metal Plaster Bases
- Z. American Society For Testing And Materials (ASTM) D226 Standard Specification for Asphalt-Saturated Organic Felt Used in Roofing And Waterproofing
- AA. American Society For Testing And Materials (ASTM) D227 Standard Specification for Coal-Tar Saturated Organic Felt Used in Roofing and Waterproofing
- BB. American Society For Testing And Materials (ASTM) D751 Standard Test Method for Coated Fabrics
- CC. American Society For Testing And Materials (ASTM) D751 Standard Test Method for Rubber Property - Durometer Hardness
- DD. American Society For Testing And Materials (ASTM) D1248 Standard Test Method for Staining of Porous Substances by Joint Sealants
- EE. American Society For Testing And Materials (ASTM) D2240 Standard Test Method for Coated Fabrics
- FF. American Society For Testing And Materials (ASTM) D4263 Standard Test Method for Indicating Moisture in Concrete by The Plastic Sheet Method
- GG. American Society For Testing And Materials (ASTM) D4397 Standard Specification for Polyethylene Sheeting for Construction, Industrial and Agricultural Applications
- HH. American Society For Testing And Materials (ASTM) D4716 Standard Test Method for Determining the (In Plane) Flow Rate Per Unit Width and Hydraulic Transmissivity of a Geo-synthetic Using a Constant Head
- II. American Society For Testing And Materials (ASTM) E84 Standard Test Method for Surface Burning Characteristics of Building Materials
- JJ. American Society For Testing And Materials (ASTM) E90 Standard Test Method for Laboratory Measurement of Airborne Sound Transmission Loss of Building Partitions
- KK. American Society For Testing And Materials (ASTM) E96 Standard Test Methods for Water Vapor Transmission of Materials
- LL. American Society For Testing And Materials (ASTM) E413 Standard Classification for Rating Sound Insulation
- MM. American Society For Testing And Materials (ASTM) E492 Standard Test Method for Laboratory Measurement of Impact Sound Transmission Through Floor-Ceiling Assemblies Using the Tapping Machine
- NN. American Society For Testing And Materials (ASTM) E989 Standard Classification for Determination of Impact Insulation Class (IIC)
- OO. American Society of Mechanical Engineers (ASME) – ASME A112.6.3 Floor and Trench Drains
- PP. Canadian Sheet Steel Building Institute (CSSBI) Lightweight Steel Framing Binder {Publication 52M}
- QQ. Federal Housing Administration (FHA) Bulletin No. 750 Impact Noise Control in Multifamily Dwellings
- RR. Housing and Urban Development (HUD) TS 28 A Guide to Airborne, Impact and Structure-borne Noise-Control in Multifamily Dwellings
- SS. Materials And Methods Standards Association (MMSA) Bulletins 1 – 16
- TT. Metal Lath/Steel Framing Association (ML/SFA) 540 Lightweight Steel Framing Systems Manual

## Section 2: Part 1 – General Information

UU. Steel Stud Manufacturers Association (SSMA) Product Technical Information and ICBO Evaluation Service, Inc. Report ER-4943P

VV. Terrazzo, Tile And Marble Association Of Canada (TTMAC) Specification Guide 09300 Tile Installation Manual

WW. Tile Council Of North America (TCNA) Handbook For Ceramic Tile Installation

**NOTE TO SPECIFIER:** Edit for applicable reference standards.

### 1.10 System Description

A. Ceramic mosaic floor tile installed over concrete floor slabs using latex-modified Portland cement mortar and latex Portland cement grout joints.

B. Quarry tile and base installed using latex modified Portland cement mortar over a plastic Portland cement mortar bed or over a cured (pre-floated) Portland cement mortar bed with epoxy grouted joints.

**NOTE TO SPECIFIER:** The above systems are example descriptions; edit for additional applicable systems.

### 1.11 Submittals

**NOTE TO SPECIFIER:** Edit for applicable requirements.

A. Submittal Requirements: Submit the following “Required LEED Criteria” certification items as listed below. Refer to Division 1 for additional requirements:

1. A completed LEED Environmental Building Materials Certification Form. Information to be supplied generally includes:

a. Manufacturing plant locations for tile installation products.

b. LEED Credits as listed in Part 1.4B “LEED Credit Submittals”.

c. GREENGUARD Environmental Institute certificates or GreenGuard Environmental Institute Schools & Children certificates provided by the tile installation materials manufacturer on GREENGUARD letterhead stating “This product has been

GREENGUARD Indoor Air Quality Certified® by the GREENGUARD Environmental Institute under the GREENGUARD Standard for Low Emitting Products” for each tile installation product used to verify Low VOC product information.

2. Contractor’s certification of LEED Compliance: Submit Contractor’s certification verifying the installation of specified LEED Compliant products.

3. Product Cut Sheets for all materials that meet the LEED performance criteria. Submit Product Cut Sheets with Contractor or Subcontractor’s stamp, as confirmation that submitted products were installed on Project.

4. Material Safety Data Sheets for all applicable products.

B. LEED Credit Submittals for the following;

1. LEED Construction Guide for Green Building Design and Construction, 2009 Edition Credit EQ 4.1: Manufacturer’s product data for tile installation materials, including GREENGUARD Certificate on GREENGUARD letterhead stating product VOC content.

2. LEED Construction Guide for Green Building Design and Construction, 2009 Edition Credit EQ 4.3: Manufacturer’s product data for tile installation materials, including GREENGUARD Certificate on GREENGUARD letterhead stating product VOC content.

3. LEED Construction Guide for Green Building Design and Construction, 2009 Edition Credit MR 2.1: (Divert 50% from Disposal) Manufacturer’s packaging showing recycle symbol for appropriate disposition in construction waste management.

4. LEED Construction Guide for Green Building Design and Construction, 2009 Edition Credit MR 2.1: (Divert 75% from

- Disposal) Manufacturer's packaging showing recycle symbol for appropriate disposition in construction waste management.
5. LEED Construction Guide for Green Building Design and Construction, 2009 Edition Credit MR 4.1: Manufacturer's product data showing post-consumer and/or pre-consumer recycled content.
  6. LEED Construction Guide for Green Building Design and Construction, 2009 Edition Credit MR 4.2: Manufacturer's product data showing post-consumer and/or pre-consumer recycled content.
  7. LEED Construction Guide for Green Building Design and Construction, 2009 Edition Credit MR 5.1 10% Extracted, Processed & Manufactured Regionally): Product data indicating location of material manufacturer for regionally manufactured materials.
    - a. Include statement indicating cost and distance from manufacturer to Project for each regionally manufactured product.
  8. LEED Construction Guide for Green Building Design and Construction, 2009 Edition Credit MR 5.2 (20% Extracted, Processed & Manufactured Regionally): Product data indicating location of material manufacturer for regionally manufactured materials.
    - a. Include statement indicating cost and distance from manufacturer to Project for each regionally manufactured product.
  9. LEED Schools Reference Guide (Educational Projects Only), 2007 Edition Credit EQ 9 (Enhanced Acoustical Performance): Impact noise reduction test reports and product data on sound control product(s).
  10. LEED Schools Reference Guide (Educational Projects Only), 2007 Edition Credit EQ 10 (Mold Prevention): Manufacturer's packaging and/or data showing anti-microbial protection in product(s).
- C. Submit shop drawings and manufacturers' product data under provisions of Section (01300) (01340)
  - D. Submit samples of each type/style/finish/size/color of ceramic tile, mosaic, paver, trim unit or threshold under provisions of Section (01300) (01340)
  - E. Submit manufacturers' installation instructions under provisions of Section (01300) (01340)
  - F. Submit manufacturer's certification under provisions of Section (01405) that the materials supplied conform to ANSI A137.1.
  - G. Submit proof of warranty.
  - H. Submit sample of installation system demonstrating compatibility/functional relationships between adhesives, mortars, grouts and other components under provision of Section (01300) (01340). Submit proof from tile or stone manufacturer or supplier verifying suitability of tile or stone for specific application and use; including dimensional stability, water absorption, freeze/thaw resistance (if applicable), resistance to thermal cycling, and other characteristics that the may project may require. These characteristics must be reviewed and approved by the project design professional(s).
  - I. Submit list from manufacturer of installation system/adhesive/mortar/grout identifying a minimum of three (3) similar projects, each with a minimum of ten (10) years service.
  - J. For alternate materials, at least thirty (30) days before bid date submit independent laboratory test results confirming compliance with specifications listed in Part 2 – Products.

### 1.12 Quality Assurance

A. Tile Manufacturer (single source responsibility): Company specializing in ceramic tile, mosaics, pavers, trim units and/or thresholds with three (3) years minimum experience. Obtain tile from a single source with resources to provide products of consistent quality in appearance and physical properties.

B. Installation System Manufacturer (single source responsibility): Company specializing in adhesives, mortars, grouts and other installation materials with ten (10) years minimum experience and ISO 9001 certification. Obtain installation materials from single source manufacturer to insure consistent quality and full compatibility.

C. Submit laboratory confirmation of adhesives, mortars, grouts and other installation materials:

1. Identify proper usage of specified materials using positive analytical method.
2. Identify compatibility of specified materials using positive analytical method.
3. Identify proper color matching of specified materials using a positive analytical method.

D. Installer qualifications: company specializing in installation of ceramic tile, mosaics, pavers, trim units and thresholds with five (5) years documented experience with installations of similar scope, materials and design.

### 1.13 Mock-Ups

A. Provide mock-up of each type/style/finish/size/color of ceramic tile, mosaics, pavers, trim unit and threshold, along with respective installation adhesives, mortars, grouts and other installation materials, under provisions of Section (01400) (01405).

### 1.14 Pre-Installation Conference

Pre-installation conference: At least three weeks prior to commencing the work attend a meeting at the jobsite to discuss conformance with requirements of specification and job site conditions. Representatives of owner, architect, general contractor, tile subcontractor, Tile Manufacturer, Installation System Manufacturer and any other parties who are involved in the scope of this installation must attend the meeting.





**1.15 Delivery, Storage and Handling**

- A. Acceptance at Site: deliver and store packaged materials in original containers with seals unbroken and labels, including grade seal, intact until time of use, in accordance with manufacturer's instructions.
- B. Store ceramic tile and installation system materials in a dry location; handle in a manner to prevent chipping, breakage, and contamination.
- C. Protect latex additives, organic adhesives, epoxy adhesives and sealants from freezing or overheating in accordance with manufacturer's instructions; store at room temperature when possible.
- D. Store portland cement mortars and grouts in a dry location.

**1.16 Project/Site Conditions**

- A. Provide ventilation and protection of environment as recommended by manufacturer.
- B. Prevent carbon dioxide damage to ceramic tile, mosaics, pavers, trim, thresholds, as well as adhesives, mortars, grouts and other installation materials, by venting temporary heaters to the exterior.
- C. Maintain ambient temperatures not less than 50°F (10°C) or more than 100°F (38°C) during installation and for a minimum of seven (7) days after completion. Setting of portland cement is retarded by low temperatures. Protect work for extended period of time and from damage by other trades. Installation with latex portland cement mortars requires substrate, ambient and material temperatures at least 37°F (3°C). There should be no ice in slab. Freezing after installation will not damage latex portland cement mortars. Protect portland cement based mortars and grouts from direct sunlight, radiant heat, forced ventilation (heat and cold) and drafts until cured to prevent premature evaporation of moisture. Epoxy mortars and grouts require surface temperatures between 60°F (16°C)

and 90°F (32°C) at time of installation. It is the General Contractor's responsibility to maintain temperature control.

**1.17 Sequencing and Scheduling**

- A. Coordinate installation of tile work with related work.
- B. Proceed with tile work only after curbs, vents, drains, piping, and other projections through substrate have been installed and when substrate construction and framing of openings have been completed.

**NOTES FOR SPECIFIER:** Edit for project specific sequence and scheduling.

**1.18 Warranty**

The Contractor warrants the work of this Section to be in accordance with the Contract Documents and free from faults and defects in materials and workmanship for a period of 25 years. The manufacturer of adhesives, mortars, grouts and other installation materials shall provide a written twenty five (25) year warranty, which covers materials and labor – reference LATICRETE Warranty Data Sheet 025.0 for complete details and requirements. For exterior facades over steel or wood framing, the manufacturer of adhesives, mortars, grouts and other installation materials shall provide a written ten (10) year warranty, which covers replacement of LATICRETE products only – reference LATICRETE Warranty Data Sheet 230.15 for complete details and requirements.

**1.19 Maintenance**

Submit maintenance data under provisions of Section 01730. Include cleaning methods, cleaning solutions recommended, stain removal methods, as well as polishes and waxes recommended.

**1.20 Extra Materials Stock**

Upon completion of the work of this Section, deliver to the Owner 2% minimum additional tile and trim shape of each type, color, pattern and size used in the Work, as well as extra stock of adhesives, mortars, grouts and other installation materials for the Owner's use in

replacement and maintenance. Extra stock is to be from same production run or batch as original tile and installation materials.

### PART 2 – PRODUCTS

#### 2.1 Tile Manufacturers

Subject to compliance with paragraphs 1.12 and performance requirements, provide products by one of the following manufacturers:

**NOTE TO SPECIFIER:** Provide list of acceptable tile manufacturers.

#### 2.2 Wall Tile Materials

**NOTE TO SPECIFIER:** Edit for each tile type.

- A. Ceramic Tile
- B. Grade:
- C. Size:
- D. Edge
- E. Finish:
- F. Color
- G. Special shapes
- H. Location:

#### 2.3 Floor Tile Materials

**NOTE TO SPECIFIER:** Edit for each tile type.

- A. Ceramic Tile
- B. Grade:
- C. Size:
- D. Edge
- E. Finish:
- F. Color
- G. Special shapes
- H. Location:

#### 2.4 Ceramic Tile Installation Materials Manufacturer

- A. LATICRETE International, Inc.,  
1 Laticrete Park North,  
Bethany, CT 06524-3423 USA  
Phone +1.800.243.4788, +1203.393.0010  
support@laticrete.com, www.laticrete.com;  
www.laticrete.com/green

**NOTE TO SPECIFIER:** Use either the following performance specification or the proprietary specification.

#### 2.5 Performance Specification – Tile Installation Accessories

A. Waterproofing Membrane to be thin, cold applied, single component liquid and load bearing. Reinforcing fabric to be non-woven rot-proof specifically intended for waterproofing membrane. Waterproofing Membrane to be non-toxic, non-flammable, and non-hazardous during storage, mixing, application and when cured. It shall be certified by IAPMO and ICC approved as a shower pan liner and shall also meet the following physical requirements:

1. Hydrostatic Test (ASTM D4068): Pass
2. Elongation at break (ASTM D751): 20 – 30%
3. System Crack Resistance (ANSI A118.12): Pass (High)
4. 7 day Tensile Strength (ANSI A118.10): >265 psi (1.8 MPa)
5. 7 day Shear Bond Strength (ANSI A118.10) >200 psi (1.4 MPa)
6. 28 Day Shear Bond Strength (ANSI A118.4): >214 psi (1.48 – 2.4 MPa)
7. Service Rating (TCA/ASTM C627): Extra Heavy
8. Total VOC Content: < 0.05 mg/m<sup>3</sup>

B. Epoxy Waterproofing Membrane to be 3 component epoxy, trowel applied specifically designed to be used under ceramic tile, stone or brick and requires only 24 hours prior to flood testing:

1. Breaking Strength (ANSI A118.10): 450 – 530 psi (3.1-3.6 MPa)
2. Waterproofness (ANSI A118.10): No Water penetration
3. 7 day Shear Bond Strength (ANSI A118.10): 110 – 150 psi (0.8 – 1 MPa)
4. 28 Day Shear Bond Strength (ANSI A118.10): 90 – 120 psi (0.6 – 0.83 MPa)
5. 12 Week Shear Bond Strength (ANSI A118.10): 110 – 130 psi (0.8 – 0.9 MPa)
6. Total VOC Content: <3.4 g/l

C. Crack Suppression Membrane to be thin, cold applied, single component liquid and load bearing. Reinforcing fabric (if required or used) to be non-woven, rot-proof specifically intended for crack suppression membrane. Materials to be non-toxic, non-flammable, and non-hazardous during storage, mixing, application and when cured. Crack Suppression Membrane shall also meet the following physical requirements:

1. Elongation at break (ASTM D751): 20 – 30%
  2. System Crack Resistance (ANSI A118.12) Pass (High)
  3. 7 day Tensile Strength (ANSI A118.10): 265 – 300 psi (1.8 – 2.0 MPa)
  4. 7 day Shear Bond Strength (ANSI A118.10) 200 – 275 psi (1.4 – 1.9 MPa)
  5. 28 Day Shear Bond Strength (ANSI A118.4): >214 – 343 psi (1.48 – 2.4 MPa)
  6. Service Rating (TCA/ASTM C627): Extra Heavy
  7. Total VOC Content: < 0.05 mg/m<sup>3</sup>
- D. Wire Reinforcing: 2" x 2" (50 x 50 mm) x 16 ASW gauge or 0.0625" (1.6 mm) diameter galvanized steel welded wire mesh complying with ANSI A108.02 3-7, ASTM A185 and ASTM A82.
- E. Cleavage membrane: 15 pound asphalt saturated, non-perforated roofing felt complying with ASTM D226, 15 pound coal tar saturated, non-perforated roofing felt complying with ASTM D227 or 4.0 mils (0.1 mm) thick polyethylene plastic film complying with ASTM D4397.
- F. Cementitious backer board units: size and thickness as specified, complying with ANSI A118.9.
- G. Thresholds: Provide marble saddles complying with ASTM C241 for abrasion resistance and ASTM C503 for exterior use, in color, size, shape and thickness as indicated on drawings.

**NOTE TO SPECIFIER:** Edit applicable tile installation accessories.

## 2.6 Performance Specification – Tile Installation Materials

- A. Sound Abatement and Crack Isolation Mat shall be load bearing, shock and vibration resistant. It shall be certified by independent laboratory testing to meet the specified acoustical performance when installed in a Floor Assembly with a 6" (150 mm) concrete slab, as well as meet the following physical requirements:
1. Service Rating (ASTM C627): Light
  2. Point Load (ANSI A118.12-5.2): >1250 psi (8.6 MPa)
  3. Installed Weight (ASTM C905 Modified): 2.6 lbs/ft<sup>2</sup> (12.8 kg/m<sup>2</sup>)
  4. Delta Impact Insulation Class (ΔIIC; ASTM E2179): 20
- B. Sound Abatement and Crack Suppression Adhesive shall comply with ANSI A118.12, provide an Extra Heavy rating and provide a minimum ΔIIC of 15:
1. Service Rating (ASTM C627): Extra Heavy
  2. Delta Impact Insulation Class (ΔIIC; ASTM E2179): 15
  3. Point Load (ANSI A118.12 5.2): >1000 psi (6.9 MPa)
  4. Minimum Shear Bond Strength (ANSI A118.12): 100psi (0.7 MPa)
- C. Moisture Vapor Reduction to be epoxy based and GREENGUARD compliant as well as meet the following physical requirements:
1. Shear Bond to Concrete (ANSI A118.12 – 5.1.5): >285 psi (2.0 MPa)
  2. Alkalinity Resistance (ASTM C267): Pass
  3. Permeability (ASTM F1869): 9.7 lbs/1,000 ft<sup>2</sup>/24 hours down to 0.2 lbs/1,000 ft<sup>2</sup>/24 hours (248 μg/s•m<sup>2</sup> down to 11 μg/s•m<sup>2</sup>)

## Section 2: Part 2 – Products

- D. Latex Portland Cement Mortar for thick beds, screeds, leveling beds and scratch/plaster coats to be weather, frost, shock resistant and meet the following physical requirements:
1. Compressive Strength (ANSI A118.4 Modified): >4000 psi (27.6 MPa)
  2. Water Absorption (ANSI A118.6):  $\leq 5\%$
  3. Service Rating (TCA/ASTM C627): Extra Heavy
  4. Smoke and Flame Contribution (ASTM E84 Modified): 0
  5. Total VOC Content: < 0.05 mg/m<sup>3</sup>
- E. Self-Leveling Underlayment shall be mixed with water to produce a pumpable, fast setting, free flowing cementitious underlayment which can be poured from a feather-edge to 1-1/2" (38 mm) thick in one pour.
1. 4 Hour Compressive Strength (ANSI A118.4 Mod.): >1500 psi (10.3 MPa)
  2. 1 Day Compressive Strength (ANSI A118.4 Mod.): >2800 psi (19.3 MPa)
  3. 28 Day Compressive Strength (ANSI A118.4 Mod.): >4300 psi (29.7 MPa)
  4. Tensile Strength (ANSI A118.7): >500 psi (3.5 MPa)
  5. Time To Foot Traffic: 3 – 4 Hours
  6. Total VOC Content: <0.05 mg/m<sup>3</sup>
- F. Epoxy Adhesive to be chemical resistant 100% solids epoxy with high temperature resistance and meet the following minimum physical requirements:
1. Compressive strength (ANSI A118.3): >5000 psi (34.4 MPa)
  2. Shear Bond Strength (ANSI A118.3): >1250 psi (8.6 MPa)
  3. Thermal Shock Resistance (ANSI A118.3): >600 psi (4.1 MPa)
  4. Tensile Strength (ANSI A118.3): >1400 psi (9.6 MPa)
  5. Shrinkage (ANSI A118.3): 0 – 0.1%
  6. Total VOC Content: <0.05 mg/m<sup>3</sup>
  7. Cured Epoxy Adhesive to be chemically and stain resistant to ketchup, mustard, tea, coffee, milk, soda, beer, wine, bleach (5% solution), ammonia, juices, vegetable oil, detergents, brine, sugar, cosmetics and blood, as well as chemically resistant to dilute food acids, dilute alkalis, gasoline, turpentine and mineral spirits.
- G. Latex Portland Cement Thin Bed Mortar for thin set and slurry bond coats to be weather, frost, shock resistant, non-flammable and meet the following physical requirements:
1. Compressive strength (ANSI A118.4): >2500 psi (17.2 MPa)
  2. Bond strength (ANSI A118.4): >450 psi (3.1 MPa)
  3. Smoke and Flame Contribution (ASTM E84 Modified): 0
  4. Total VOC Content: <0.05 mg/m<sup>3</sup>
- H. Organic Adhesive shall be non-flammable, water resistant, latex adhesive and shall meet the following physical requirements:
1. Open Time (ANSI A136.1): 70 minutes at 75°F (24°C)
  2. Color: White
  3. Density (ANSI A136.1): 13.2 lbs/gal (1.6 kg/l)
- I. Epoxy Grout (Industrial) to be non-flammable, chemical resistant 100% solids epoxy with high temperature resistance and meeting the following physical requirements:
1. Initial Set Time (ANSI A118.5): Pass (4 hours)
  2. Service Set Time (ANSI A118.5): Pass (<7 days)
  3. Shrinkage (ANSI A118.3): Pass (0.07%)
  4. Sag (ANSI A118.3): Pass (no sag)
  5. Shear Bond Strength (ANSI A118.3; quarry tile): 1000 psi (6.9 MPa)
  6. Compressive Strength (ANSI A118.3): 15500 psi (107 MPa)

7. Tensile Strength (ANSI A118.5): 2600 psi (18.0 MPa)
  8. Thermal Shock Resistance (ANSI A118.3): 500 psi (3.4 MPa)
  9. Cured Epoxy Grout to be chemically and stain resistant to ketchup, mustard, tea, coffee, milk, soda, beer, wine, bleach (3% solution), ammonia, juices, vegetable oil, detergents, brine, sugar, cosmetics and blood, as well as being chemically resistant to dilute food/mineral acids, gasoline and mineral spirits.
- J. Epoxy Grout (Commercial/Residential) shall be non-toxic, non-flammable, non-hazardous during storage, mixing, application and when cured and shall meet the following physical requirements:
1. Compressive Strength (ANSI A118.3): 3500 psi (24 MPa)
  2. Shear Bond Strength (ANSI A118.3): 1000 psi (6.9 MPa)
  3. Tensile Strength (ANSI A118.3): 1100 psi (7.6 MPa)
  4. Thermal Shock (ANSI A118.3): >500 psi (3.5 MPa)
  5. Water Absorption (ANSI A118.3): <0.5 %
  6. Vertical Joint Sag (ANSI A118.3): Pass
  7. Total VOC Content: <0.05 mg/m<sup>3</sup>
  8. Cured Epoxy Grout to be chemically and stain resistant to ketchup, mustard, tea, coffee, milk, soda, beer, wine, bleach (5% solution), ammonia, juices, vegetable oil, brine, sugar, cosmetics, and blood, as well as chemically resistant to dilute acids and dilute alkalis.
- K. Latex Portland Cement Grout to be weather, frost and shock resistant, as well as meet the following physical requirements:
1. Compressive Strength (ANSI A118.7): 4500 psi (31 MPa)
  2. Tensile Strength (ANSI A118.7): >500 psi (3.45 MPa)
  3. Flexural Strength (ANSI A118.7): >1250 psi (8.6 MPa)
  4. Water Absorption (ANSI A118.7): <5%
  5. Linear Shrinkage (ANSI A118.7): <0.05 %
  6. Smoke and Flame Contribution (ASTM E84 Modified): 0
  7. Total VOC Content: <0.05 mg/m<sup>3</sup>
- L. Expansion and Control Joint Sealant to be a one component, neutral cure, exterior grade silicone sealant and meet the following requirements:
1. Tensile Strength (ASTM C794): 280 psi (1.9 MPa)
  2. Hardness (ASTM D751; Shore A): 25 (colored sealant) /15 (clear sealant)
  3. Weather Resistance (QUV Weatherometer): 10000 hours (no change)
- M. Roof Decks (and other exterior paving applications over occupied/storage spaces) shall consist of a Primary Roofing/Waterproofing Membrane, as specified in Section 0700 (q.v.), and a lightweight, frost/weather resistant installation system for tile, pavers, brick and stone that provides integral subsurface drainage and meets the following physical requirements:
1. Compressive Strength (ASTM C109 Modified): 3000 psi (20.7 MPa)
  2. Hydraulic Transmissivity (ASTM D4716): 1.6 gal/minute (6.1 l/minute)
  3. Service Rating (ASTM C627): Extra Heavy
- N. Spot Bonding Epoxy Adhesive for installing tile, brick and stone over vertical and overhead surfaces shall be high strength, high temperature resistant, non-sag and shall meet the following physical requirements:
1. Thermal Shock Resistance (ANSI A118.3): >1000 psi (6.9 MPa)
  2. Water Absorption (ANSI A118.3): 0.1 %
  3. Compressive Strength (ANSI A118.3): >8300 psi (57.2 MPa)

## Section 2: Part 3 – Execution Statement

4. Shear Bond Strength (ANSI A118.3 Modified): >730 psi (5 MPa)

**NOTE TO SPECIFIER:** Edit applicable tile installation materials.

### 2.7 Proprietary Specification – Tile Installation Accessories

Installation accessories as manufactured by LATICRETE International, Inc.,  
1 LATICRETE Park North,  
Bethany, CT 06524-3423 USA.  
Phone +1.800.243.4788,  
www.laticrete.com

- A. Waterproofing Membrane: LATICRETE® Hydro Ban™\*\* as manufactured by LATICRETE International, Inc.
- B. Epoxy Waterproofing Membrane: LATAPOXY® 24hr HydroProofing™ as manufactured by LATICRETE International, Inc.
- C. Crack Suppression Membrane: LATICRETE Blue 92 Anti-Fracture Membrane\*\* as manufactured by LATICRETE International, Inc.

**NOTE TO SPECIFIER:** Edit applicable tile installation accessories.

### 2.8 Proprietary Specification – Tile Installation Materials

Installation materials as manufactured by LATICRETE International, Inc.,  
1 LATICRETE Park North,  
Bethany, CT 06524-3423 USA.  
Phone +1.800.243.4788,  
www.laticrete.com; www.laticrete.com/green

- A. Sound Control Underlayment: LATICRETE 170 Sound & Crack Isolation Mat (Standard or PLUS Configurations) as manufactured by LATICRETE International, Inc.
- B. Latex-Portland Cement Mortar for thick beds, screeds, leveling beds and scratch/plaster coats: LATICRETE 3701 Fortified Mortar Bed\*\* as manufactured by LATICRETE International, Inc.
- C. Self-Leveling Underlayment: LATICRETE 86 Latilevel™\*\* as manufactured by LATICRETE International, Inc.

- D. Moisture Vapor Reduction: LATAPOXY 312 Vapor Reduction Membrane\*\* as manufactured by LATICRETE International, Inc.

- E. Epoxy Adhesive: LATAPOXY 300 Adhesive\*\* as manufactured by LATICRETE International, Inc.

- F. Latex Portland Cement Thin Bed Mortar: LATICRETE 254 Platinum\*\* as manufactured by LATICRETE International, Inc.

- G. Sound & Crack Isolation Adhesive: LATICRETE 125 Sound & Crack Adhesive\*\* as manufactured by LATICRETE International, Inc.

- H. Organic Adhesive: LATICRETE 15 Premium Mastic as manufactured by LATICRETE International, Inc.

- I. Epoxy Grout (Industrial): LATAPOXY 2000 Industrial Grout\*\* as manufactured by LATICRETE International, Inc.

- J. Epoxy Grout (Commercial/Residential): LATICRETE SpectraLOCK® PRO Grout† as manufactured by LATICRETE International, Inc.

- K. Latex Portland Cement Grout: LATICRETE PermaColor™ Grout^ as manufactured by LATICRETE International, Inc.

- L. Expansion and Control Joint Sealant: LATICRETE LataSil as manufactured by LATICRETE International, Inc.

- M. Roof Deck: LATICRETE Plaza & Deck System as manufactured by LATICRETE International, Inc.

- N. Spot Bonding Epoxy Adhesive: LATAPOXY 310 Stone Adhesive (Standard or Rapid Grade) as manufactured by LATICRETE International, Inc.

### PART 3 – EXECUTION

#### 3.1 Substrate Examination

A. Verify that surfaces to be covered with ceramic tile, mosaics, pavers, brick, stone, trim or waterproofing are:

1. Sound, rigid and conform to good design/engineering practices;
2. Systems, including the framing system and panels, over which tile or stone will be installed shall be in conformance with the International Residential Code (IRC) for residential applications, the International Building Code (IBC) for commercial applications, or applicable building codes. The project design should include the intended use and necessary allowances for the expected live load, concentrated load, impact load, and dead load including the weight of the finish and installation materials;
3. Clean and free of dust, dirt, oil, grease, sealers, curing compounds, laitance, efflorescence, form oil, loose plaster, paint, and scale;
4. Thin-set tile installations have a specified subsurface tolerance, for instance 1/4" in 10' (6 mm in 3 m) and 1/16" in 1' (1.5 mm in 300 mm), to conform with the ANSI specifications. Because thin-set is not intended to be used in truing or leveling the work of others, the subsurface typically should not vary by more than 1/16" over 1' (1.5 mm over 300 mm), nor more than 1/32" (0.8 mm) between adjoining edges where applicable (e.g. between sheets of exterior glue plywood or between adjacent concrete masonry units). Should the architect/designer require a more stringent tolerance (e.g. 1/8" in 10' [3 mm in 3 m]), the subsurface specification must reflect that tolerance, or the tile specification must include a specific and separate requirement to bring the 1/4" (6 mm) subsurface tolerance into compliance with the 1/8" (6 mm) tolerance desired;

5. Not leveled with gypsum or asphalt based compounds;

6. Dry as per American Society for Testing and Materials (ASTM) D4263 "Standard Test for Determining Moisture in Concrete by the Plastic Sheet Method."

B. Concrete surfaces shall also be:

1. Cured a minimum of 28 days at 70°F (21°C), including an initial seven (7) day period of wet curing;

**NOTE TO SPECIFIER: LATICRETE® latex portland cement mortars do not require a minimum cure time for concrete substrates or mortar beds;**

2. Wood float finished, or better, if the installation is to be done by the thin bed method;

C. Advise General Contractor and Architect of any surface or substrate conditions requiring correction before tile work commences. Beginning of work constitutes acceptance of substrate or surface conditions.

#### 3.2 Surface Preparation

A. Requirements

Steam Rooms require a waterproofing membrane on all surfaces to prevent moisture from penetrating adjoining spaces. Additionally, a vapor barrier (6 mil thick polyethylene sheeting or #15 Builders Felt) must be installed over the steel framing (or substrate) and behind the insulation board. Vapor barrier shall be designed for relative temperature exposure. Install vapor barrier so that it laps over the shower pan waterproofing membrane so that condensation can drain into the shower pan (not behind it) – see associated detail SR-614. All steam rooms will require adequate insulation on walls and ceilings to reduce moisture condensation at temperature variations. Slope ceilings 2" per foot (50 mm per 300 mm) minimum to avoid condensation from dripping onto occupants. Install open slip joints in all corners between walls and ceiling and to divide areas that exceed 16' (480 cm) in length. For more information on the floor

installation; follow method ESB414. For more information on the wall and ceiling installation; follow method ES-W221(I).

Structure to receive the installation assembly must be sound, solid, well bonded, stripped clean and free from dust, wax, grease, sealer and all other contamination which may reduce or prevent adhesion.

B. Bonded Thick Bed – Pitch Layer Over Floor Substrate – To provide pitch over a concrete deck, prepare a LATICRETE® latex leveling bed mix (see § 3.4D thick bed mortar material below applied over a slurry bond coat consisting of LATICRETE 254 Platinum). Apply mortar over dampened substrate. Pitch layer 1/4" per 1' (6 mm per 0.3 m) per ANSI A108.1A (2.3.4).

C. List other Substrates as required and means of preparation as required)

(Insert any Special Means of Preparation – In addition to the surface preparation requirements listed above; ...)

**NOTE TO SPECIFIER:** The above are example surface categories; edit for project specific surfaces and conditions.

### 3.3 Installation – Accessories

(edit as required)

### 3.4 Installation – Tile, Brick and Stone

A. General: Install in accordance with current versions of American National Standards Institute, Inc. (ANSI) “A108 American National Standard Specifications for Installation of Ceramic Tile” and TCNA “Handbook for Ceramic Tile Installation.” Cut and fit ceramic tile, brick or stone neatly around corners, fittings, and obstructions. Perimeter pieces to be minimum half tile, brick or stone. Chipped, cracked, split pieces and edges are not acceptable. Make joints even, straight, plumb and of uniform width to tolerance +/- 1/16" over 8' (1.5 mm in 2.4 m). Install divider strips at junction of flooring and dissimilar materials.

B. Lath and Plaster Method: Install prior to installing the waterproofing membrane: Install cleavage membrane complying with current revision of ANSI A108.02 (3.8 Membrane or cleavage membrane). Install metal lath complying with the current revision of ANSI A108.1 (3.3 Requirements for lathing and portland cement plastering, ANSI A108.02 (3.6 Metal lath) and A108.1A (1.0 – 1.2, 1.4, and 5.1). Apply latex-portland cement mortar as scratch/leveling coat over wire lath, concrete or masonry in compliance with current revision of ANSI A108.01 (3.3.5.1) and A108.1A (1.4). Float surface of scratch/leveling coat plumb, true and allow mortar to set until firm. For installation of tile, brick or stone, follow Thin Bed Method (§ 3.4E).

#### Use the following LATICRETE® System Materials

LATICRETE 3701 Fortified Mortar Bed

LATICRETE 254 Platinum

#### References

LATICRETE Data Sheets: 100.0; 677.0

LATICRETE MSDS: 3701FMB; 254

GREENGUARD Certificates: 3701FMB; 254

LATICRETE Technical Data Sheets: 106, 114, 122, 199, 204

C. Waterproofing Membrane installed over pre-sloped floor substrate under the mortar bed and over vertical Lath and Plaster portland cement scratch and brown coat walls and ceilings. Membrane must be used on all areas in the steam room. Loop membrane into all slip joints to allow for movement in these areas.

**NOTE TO SPECIFIER:** Adhesives/mastics, mortars and grouts for ceramic tile, mosaics, pavers, brick and stone are not replacements for waterproofing membranes and will not prevent water penetration into occupied or storage spaces below. Drains must be a two-part clamping ring style drains with weepers and as per ASME A112.6.3. Place tile spacers or gravel around weep holes to prevent mortar from clogging the weep holes.



Install the waterproofing membrane in compliance with current revisions of ANSI A108.1 (2.7 Waterproofing) and ANSI A108.13. Review the installation and plan the application sequence. Pre-cut LATICRETE Waterproofing/Anti-Fracture Fabric (if required), allowing 2" (50 mm) for overlap at ends and sides to fit the areas as required. Roll up the pieces for easy handling and placement. Shake or stir LATICRETE Hydro Ban™ before using.

**Pre-Treat Cracks and Joints** – Fill all substrate cracks, cold joints and control joints to a smooth finish using a LATICRETE latex-fortified thin-set. Alternatively, a liberal coat\* of LATICRETE Hydro Ban applied with a paint brush or trowel may be used to fill in non-structural joints and cracks. Apply a liberal coat\* of LATICRETE Hydro Ban approximately 8" (200 mm) wide over substrate cracks, cold joints, and control joints using a paint brush or heavy napped paint roller.

**Pre-Treat Coves and Floor/Wall Intersections** – Fill all substrate coves and floor/wall transitions to a smooth finish and changes in plane using a LATICRETE latex-fortified thin-set. Alternatively, a liberal coat\* of LATICRETE Hydro Ban applied with a paint brush or trowel may be used to fill in cove joints and floor/wall transitions <1/8" (3 mm) in width. Apply a liberal coat\* of LATICRETE Hydro Ban approximately 8" (200 mm) wide over substrate cracks, cold joints, and control joints using a paint brush or heavy napped paint roller.

**Pre-Treat Drains** – Drains must be of the clamping ring type, with weepers as per ASME A112.6.3. Apply a liberal coat\* of LATICRETE Hydro Ban around and over the bottom half of drain clamping ring. Cover with a second liberal coat of LATICRETE Hydro Ban. When the LATICRETE Hydro Ban dries, apply a bead of LATICRETE Latasil™ where the LATICRETE Hydro Ban meets the drain throat. Install the top half of drain clamping ring.

**Pre-Treat Penetrations** – Allow for a minimum 1/8" (3 mm) space between drains, pipes, lights, or other penetrations and surrounding ceramic tile, stone or brick. Pack any gaps around pipes, lights or other penetrations with a LATICRETE latex-fortified thin-set. Apply a liberal coat\* of LATICRETE Hydro Ban around penetration opening. Cover the first coat with a second liberal coat\* of LATICRETE Hydro Ban. Bring LATICRETE Hydro Ban up to level of tile or stone. When LATICRETE Hydro Ban has dried to the touch seal with LATICRETE Latasil.

**Main Application** – Allow any pre-treated areas to dry to the touch. Apply a liberal coat\* of LATICRETE Hydro Ban with a paint brush or heavy napped roller over substrate including pre-treated areas and allow to dry to the touch. Install another liberal coat\* of LATICRETE Hydro Ban over the first coat. Let the top coat of LATICRETE Hydro Ban dry to the touch approximately 1 – 2 hours at 70°F (21°C) and 50% RH. When the top coat has dried to the touch inspect the surface for pinholes, voids, thin spots or other defects. LATICRETE Hydro Ban will dry to an olive green color when fully cured. Use additional LATICRETE Hydro Ban to seal any defects.

**Movement Joints** – Apply a liberal coat\* of LATICRETE Hydro Ban, approximately 8" (200 mm) wide over the areas. Then embed and loop the 6" (150 mm) wide LATICRETE Waterproofing/Anti-Fracture Fabric and allow the LATICRETE Hydro Ban liquid to bleed through. Immediately apply a second coat of LATICRETE Hydro Ban.

\* Dry coat thickness is 20 – 30 mil (0.02 – 0.03" or 0.5 – 0.8 mm); consumption per coat is approximately 0.01 gal/ft<sup>2</sup> (approx. 0.4 l/m<sup>2</sup>); coverage is approximately 100 ft<sup>2</sup>/gal (approx. 2.5 m<sup>2</sup>/l). LATICRETE® Waterproofing/Anti-Fracture Fabric can be used to pre-treat cracks, joints, curves, corners, drains, and penetrations with LATICRETE Hydro Ban™.

**Protection** – Provide protection for newly installed membrane, even if covered with a thin-bed ceramic tile, stone or brick installation against exposure to rain or other water for a minimum of 2 hours at 70°F (21°C) and 50% RH. For temperatures between 45°F and 69°F (7°C to 21°C) allow a minimum 24 hour cure period.

**Flood Testing** – Allow membrane to cure fully before flood testing, typically a minimum 2 hours at 70°F (21°C) and 50% RH. Cold conditions will require a longer curing time. For temperatures between 50°F and 69°F (10°C to 21°C) allow a minimum 24 hour cure period prior to flood testing.

### Use the following LATICRETE® System Materials

LATICRETE® Hydro Ban™

### References

LATICRETE Detail Drawings: WP300, WP301, WP302, WP303

LATICRETE Data Sheets: 663.0, 663.5

LATICRETE MSDS: Hydro Ban, Fabric

GREENGUARD Certificate: Hydro Ban

LATICRETE Technical Data Sheets: 188, 189, 203, 169

D. Bonded Thick Bed Method: Apply a slurry bond coat consisting of LATICRETE 254 Platinum. Apply mortar over dampened substrate. Pitch layer 1/4" per 1' (6 mm per 300 mm) per ANSI A108.1A (2.3.4). While slurry bond coat is wet and tacky, embed the mortar bed of LATICRETE 3701 Fortified Mortar Bed mixed with water in compliance with current revision of ANSI A108.1A (2.2 and 5.2) and compact mortar by tamping with flat trowel. Screed mortar bed level and provide correct slopes to drains.

### Use the following LATICRETE System Materials

LATICRETE 3701 Fortified Mortar Bed

LATICRETE 254 Platinum

### References

LATICRETE Data Sheets: 100.0; 677.0

LATICRETE MSDS: 3701FMB; 254

GREENGUARD Certificates: 3701FMB; 254  
LATICRETE Technical Data Sheets: 106, 114, 128, 143, 154, 199, 204

E. Thin Bed Method: Install latex portland cement mortar in compliance with current revisions of ANSI A108.02 (3.11), A108.1B and ANSI A108.5. Use the appropriate trowel notch size to ensure proper bedding of the tile, brick or stone selected. Work the latex portland cement mortar into good contact with the substrate and comb with notched side of trowel. Spread only as much latex portland cement mortar as can be covered while the mortar surface is still wet and tacky. When installing large format (>8" x 8"/200 mm x 200 mm) tile/stone, rib/button/lug back tiles, pavers or sheet mounted ceramics/mosaics, spread latex portland cement mortar onto the back of (i.e. "back-butter") each piece/sheet in addition to trowelling latex portland cement mortar over the substrate. Beat each piece/sheet into the latex portland cement mortar with a beating block or rubber mallet to insure full bedding and flatness. Allow installation to set until firm. Clean excess latex portland cement mortar from tile or stone face and joints between pieces.

### Use the following LATICRETE System Materials

LATICRETE 254 Platinum

### References

LATICRETE Data Sheet: 677.0

LATICRETE MSDS: 254

GREENGUARD Certificate: 254

LATICRETE Technical Data Sheets: 105, 118, 199, 209

F. Grouting or Pointing:

**NOTE TO SPECIFIER:** Select one of following and specify color for each type/color of ceramic tile, mosaic, paver, trim unit:

1. Chemical Resistant, Water Cleanable Tile-Grouting Epoxy (ANSI A118.3): Follow manufacturer's recommendations for minimum cure time prior to grouting. Store liquid components of LATICRETE SpectraLOCK® PRO Grout† for 24 hours at 70 – 80°F (21 – 27°C) prior to use to facilitate mixing and application. Substrate temperature must be 40 – 95°F (4 – 35°C). Verify joints are free of dirt, debris or grout spacers. Sponge or wipe dust/dirt off tile faces and remove water standing in joints. Apply grout release to face of absorptive, abrasive, non-slip or rough textured ceramic tile, pavers, bricks, stone or trim units that are not hot paraffin coated to facilitate cleaning. Cut open pouch and pour LATICRETE SpectraLOCK PRO Grout Part A Liquid into a clean mixing pail. Then open pouch and pour LATICRETE SpectraLOCK PRO Grout Part B Liquid into the mixing pail. Mix by hand or with a slow speed (<300 rpm) mixer until the two liquids are well blended. Then, while mixing, add LATICRETE SpectraLOCK PRO Grout Part C Powder and blend until uniform. Install LATICRETE SpectraLOCK PRO Grout in compliance with current revisions of ANSI A108.02 (3.13) and ANSI A108.6 (3.0 – 4.0). Spread using a sharp edged, hard rubber float and work grout into joints. Using strokes diagonal (at 45° angle) to the grout lines, pack joints full and free of voids/pits. Then hold float face at a 90° angle to grouted surface and use float edge to “squeeze” off excess grout, stroking diagonally to avoid pulling grout out of filled joints. Once excess grout is removed, a thin film/haze will be left. Initial cleaning of the remaining film/haze can begin approximately 20 – 30 minutes after grouting (wait longer at colder temperatures). Begin by mixing cleaning additive packet with 2 gallons (7.6 l) of clean water in a clean bucket to make cleaning solution. Dip a clean

sponge into the bucket and then wring out cleaning solution until sponge is damp. Using a circular motion, lightly scrub grouted surfaces with the damp sponge to dissolve grout film/haze. Then drag sponge diagonally over the scrubbed surfaces to remove froth. Rinse sponge frequently and change cleaning solution at least every 50 ft<sup>2</sup> (4.7 m<sup>2</sup>). Discard sponges as they become “gummy” with residue. Within one (1) hour of finishing first cleaning, clean the same area again following the same procedure but utilizing a clean white scrub pad and fresh cleaning solution. Rinse scrub pad frequently. Drag a clean sponge diagonally over the scrubbed surfaces to remove froth. Use each side of sponge only once before rinsing and change cleaning solution at least every 50 ft<sup>2</sup> (4.7 m<sup>2</sup>). Allow cleaned areas to dry and inspect tile/stone surface. For persistent grout film/haze (within 24 hours), repeat scrubbing procedure with undiluted white vinegar and clean pad. Rinse with clean water and allow surface to dry. Inspect grout joint for pinholes/voids and repair them with freshly mixed LATICRETE SpectraLOCK PRO Grout. CAUTIONS: Do not use undiluted white vinegar on polished marble or limestone unless a test spot in an inconspicuous area indicates no change in finish appearance; do not use acid cleaners on epoxy grout less than 7 days old.

### Use the following LATICRETE System Materials

LATICRETE SpectraLOCK PRO Grout

### References

LATICRETE Data Sheets: 685.0, 685.5

LATICRETE MSDS: Pro Part A, Pro Part B, Part C Powder, Cleaning Additive

GREENGUARD Certificate: PRO

LATICRETE Technical Data Sheets: 111, 198, 212, 400

2. Polymer Fortified Cement Grout (ANSI A118.7): Allow ceramic tile, mosaics, pavers, brick or stone installation to cure a minimum of 24 hours at 70°F (21°C). Verify grout joints are free of dirt, debris or tile spacers. Sponge or wipe dust/dirt off veneer face and remove any water standing in joints. Apply grout release to face of absorptive, abrasive, non-slip or rough textured ceramic tile, pavers, bricks, or trim units that are not hot paraffin coated to facilitate cleaning. Surface temperature must be between 40–90°F (4–32°C). Pour approximately 64 oz. (1.9 l) of clean, potable water into a clean mixing container. Add a 25 lb (11.3 kg) bag of LATICRETE® PermaColor™ Grout<sup>^</sup> to the container while mixing. Mix by hand or with a slow speed mixer to a smooth, stiff consistency. Install latex fortified cement grout in compliance with current revisions of ANSI A108.1A (7.0 Grouting of tile), ANSI A108.02 (4.5 Cleaning tile) and ANSI A108.10. Dampen dry surfaces with clean water. Spread using a sharp edged, hard rubber float and work grout into joints. Using diagonal (at 45° angle to direction of grout line) strokes, pack joints full and free of voids/pits. Hold float face at a 90° angle to grouted surface and use float edge to “squeegee” off excess grout, stroking diagonally to reduce pulling grout out of filled joints. Initial cleaning can begin as soon as grout has become firm, typically 15 – 20 minutes after grouting at 70°F (21°C). Higher temperatures may require faster time to initial cleaning; wider joints or lower temperatures may require a longer time to initial cleaning. Begin initial cleaning by lightly dampening the entire grouted area with a damp sponge. Then wash clean the entire area with a damp (not wet) sponge. Drag a clean towel, dampened with water, or wipe a clean, dampened sponge, diagonally over the

veneer face to remove any grout haze left after “squeegeeing.” Rinse towel/sponge frequently and change rinse water at least every 200 ft<sup>2</sup> (19 m<sup>2</sup>). Repeat this cleaning sequence again if grout haze is still present. Allow grout joints to become firm. Buff surface of grout with clean coarse cloth. Inspect joint for pinholes/voids and repair them with freshly mixed grout. Within 24 hours, check for remaining haze and remove it with warm soapy water and a nylon scrubbing pad, using a circular motion, to lightly scrub surfaces and dissolve haze/film. Do not use acid cleaners on latex portland cement grout less than 10 days old.

**NOTE TO SPECIFIER:** Select one of following and specify color for each type/color of ceramic tile, mosaic, paver, trim unit:

1. Latex-portland cement sanded floor grout for joint widths  $\geq 1/16"$  (1.5 mm) and  $\leq 1/2"$  (12 mm);
2. Latex-portland cement unsanded grout for soft glazed tiles and soft/polished stone with joints widths  $\leq 1/8"$  (3 mm).

**Use the following LATICRETE® System Materials**  
LATICRETE PermaColor Grout

### References

LATICRETE Data Sheets: 250.0

LATICRETE MSDS: 2500

GREENGUARD Certificates: 2500

LATICRETE Technical Data Sheets: 201, 400

G. Expansion and Control Joints: Provide control or expansion joints as located in contract drawings and in full conformity, especially in width and depth, with architectural details.

1. Substrate joints must carry through, full width, to surface of tile, brick or stone.
2. Install expansion joints in tile, brick or stone work over construction/cold joints or control joints in substrates.
3. Install expansion joints where tile, brick or stone abut restraining surfaces (such as perimeter walls, curbs, columns), changes in plane and corners.

4. Joint width and spacing depends on application – follow TCNA “Handbook for Ceramic Tile Installation” Detail “EJ-171 Expansion Joints” or consult sealant manufacturer for recommendation based on project parameters.
5. Joint width:  $\geq 1/8$ " (3 mm) and  $\leq 1$ " (25 mm).
6. Joint width: depth ~2:1 but joint depth must be  $\geq 1/8$ " (3 mm) and  $\leq 1/2$ " (12 mm).
7. Layout (field defined by joints): 1:1 length: width is optimum but must be  $\leq 2:1$ . Remove all contaminants and foreign material from joint spaces/surfaces, such as dirt, dust, oil, water, frost, setting/grouting materials, sealers and old sealant/backer. Use LATICRETE Latasil™ 9118 Primer for underwater and permanent wet area applications, or for porous stone (e.g. limestone, sandstone etc...) installations. Install appropriate backing material (e.g. closed cell backer rod) based on expansion joint design and as specified in § 07920. Apply masking tape to face of tile, brick or stone veneer. Use caulking gun, or other applicator, to completely fill joints with sealant. Within 5 – 10 minutes of filling joint, ‘tool’ sealant surface to a smooth finish. Remove masking tape immediately after tooling joint. Wipe smears or excess sealant off the face of non-glazed tile, brick, stone or other absorptive surfaces immediately.

**Use the following LATICRETE System Materials**

LATICRETE Latasil

LATICRETE Latasil 9118 Primer

**References**

LATICRETE Detail Drawings: WP300, WP301, WP302, WP303, EJ-01, EJ-02, EJ-03, EJ-04, EJ-05, EJ-06, EJ-07, EJ-08, EJ-09, EJ-10, EJ-11, EJ-12, EJ-13, EJ-14, EJ-15, P605 (Sealant treatments only)

LATICRETE Data Sheets: 6200.1, 6528.1

LATICRETE MSDS: Latasil, Primer

LATICRETE Technical Data Sheets: 211, 252

- H. Adjusting: Correction of defective work for a period of one (1) year following substantial completion, return to job and correct all defective work. Defective work includes, without limitation, tiles broken in normal abuse due to deficiencies in setting bed, loose tiles or grout, and all other defects which may develop as a result of poor workmanship.

**3.5 Cleaning**

Clean excess mortar/epoxy from veneer surfaces with water before they harden and as work progresses. Do not contaminate open grout/caulk joints while cleaning. Sponge and wash veneers diagonally across joints. Do not use acids for cleaning. Polish with clean dry cloth. Remove surplus materials and leave premises broom clean.

**3.6 Protection**

- A. Protect finished installation under provisions of §01500 and §01535. Close areas to other trades and traffic until tile being installed has set firmly. Keep traffic off horizontal portland cement thick bed mortar installations for at least 72 hours at 70°F (21°C)
- B. Keep floors installed with epoxy adhesive closed to foot traffic for 24 hours at 70°F (21°C), and to heavy traffic for 48 hours at 70°F (21°C) unless instructed differently by manufacturer. Use kneeling boards, or equivalent, to walk/work on newly tiled floors. Cure tile work in swimming pools, fountains and other continuous immersion applications for 10 days at 70°F (21°C) for epoxy based grout and 14 days at 70°F (21°C) for latex portland cement based grout before flood testing or filling installation with water. Extend period of protection of tile work at lower temperatures, below 60°F (15°C), and at high relative humidity (>70% RH) due to retarded set times of mortar/adhesives. Replace or restore work of other trades damaged or soiled by work under this section.

### Part 4 – Healthy and Safety

The use of personal protection such as rubber gloves, suitable dust masks, safety glasses and industrial clothing is highly recommended. Discarded packaging, product wash and waste water should be disposed of as per local, state or federal regulations.

<sup>†</sup> United States Patent No.: 6881768 (and other Patents).

<sup>^</sup> United States Patent No.:6784229 B2 (and other Patents).

<sup>\*\*</sup> GREENGUARD Indoor Air Quality Certified® and GREENGUARD for Schools & Children Indoor Air Quality Certified Product.

## Section 3: Specifications for Steam Room –Thin Bed Method



**Section 3: Detail ES-SR614**

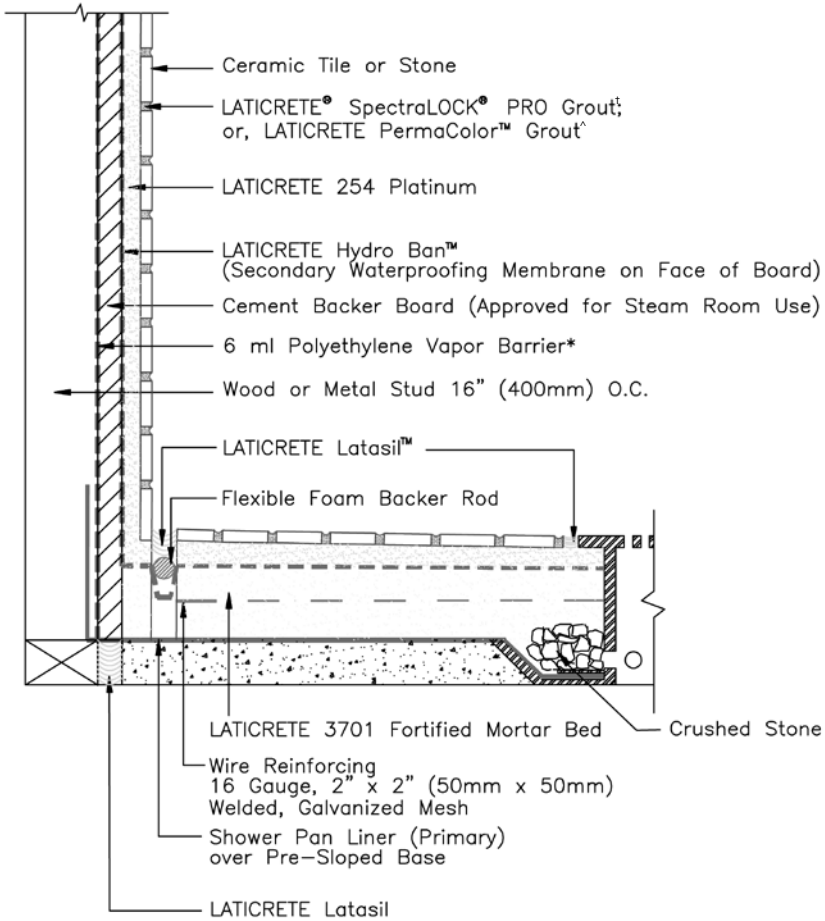

\* Vapor Barrier laps into Shower Pan Membrane (as shown)

Revision Date: 09/09  
Scale: NTS

**NOTE:** For complete application information and limitations consult related Product Data Sheets and Execution Statements related to this detail and applicable industry standards.

<sup>†</sup> United States Patent No.: 6881768 (and other Patents).

<sup>‡</sup> United States Patent No.: 6784229 B2 (and other Patents).

©2009 LATICRETE INTERNATIONAL, INC. ALL RIGHTS RESERVED. The right to utilize LATICRETE details for commercial purposes is granted exclusively to contractors, architects, quantity surveyors, engineers, and specifications writers. LATICRETE®, LATAPOXY®, SPECTRALOCK® are registered trademarks of LATICRETE International, Inc. U.S. and Foreign Patent and Trademark Offices, Marca Registrada. All other trademarks are property of their respective companies.

As a professional courtesy, LATICRETE offers technical services free of charge. The user maintains all responsibility for verifying the applicability and suitability of the technical service or information provided.



**PART 1 – GENERAL****1.1 Summary**

- A. Scope of work – Provide ceramic tile, tile installation materials and accessories as indicated on drawings, as specified herein, and as needed for complete and proper installation.
- B. Related Documents – provisions within General and Supplementary General Conditions of the Contract, Division 1 – General Requirements, and the Drawings apply to this Section.

**1.2 Section Includes**

- A. Ceramic wall tile and trim units (glazed)
- B. Ceramic floor tile/mosaics and trim units (glazed or unglazed)
- C. Ceramic tile pavers and trim units (glazed or unglazed)
- D. Quarry tile pavers and trim units (glazed or unglazed)
- E. Porcelain tile
- F. Glass mosaics
- G. Special purpose tile
- H. Decorative thin wall tile
- I. Installation Products; adhesives, mortars, grouts and sealants
- J. Waterproofing membranes for ceramic tile work
- K. Anti-fracture membranes for ceramic tile work
- L. Sound control underlayments
- M. Thresholds, trim, cementitious backer units and other accessories specified herein.

**NOTE TO SPECIFIER:** Edit for applicable procedures and materials.

**1.3 Products Furnished But Not Installed Under This Section**

**NOTE TO SPECIFIER:** Edit for applicable products.

**1.4 Products Installed But Not Furnished Under This Section**

**NOTE TO SPECIFIER:** Edit for applicable products.

**1.5 Environmental Performance Requirements**

- A. Environmental Performance Criteria: The following criteria are required for products included in this section.

Refer to Division 1 for additional requirements:

1. Products manufactured regionally within a 500 mile radius of the project site;
2. Adhesive products must meet or exceed the VOC limits of South Coast Air Quality Management District Rule #1168 and Bay Area Resources Board Reg. 8, Rule 51.

**1.6 Related Sections**

- A. Section 03300 Cast-in-Place Concrete (monolithic slab finishing for ceramic tile)
- B. Section 03305 Concrete Curing
- C. Section 03410 Structural Pre-cast Concrete
- D. Section 03532 Concrete Floor Topping
- E. Section 04200 Unit Masonry (CMU wall substrates)
- F. Section 04300 Stone
- G. Section 06100 Rough Carpentry (plywood sub-floors)
- H. Section 07110 Membrane Waterproofing
- I. Section 07920 Elastomeric Joint Sealants
- J. Section 09250 Gypsum Board Assemblies
- K. Section 09385 Stone Tile
- L. Section 10800 Washroom Accessories
- M. Section 15440 Plumbing Fixtures

**NOTE TO SPECIFIER:** Above are examples of typical broad scope and narrow scope sections related to ceramic tile installation. Edit for applicable related sections.

**1.7 Allowances**

**NOTE TO SPECIFIER:** Edit for detail of applicable ALLOWANCES; coordinate with Section 01020 Allowances. Allowances in the form of unit pricing are sometimes used when the scope of the tile work at time of bid is undetermined.

### 1.8 Alternates

**NOTE TO SPECIFIER:** Edit for applicable ALTERNATES. Alternates may be used to evaluate varying levels of performance of setting systems or to assist in the selection of the tile by economy.

### 1.9 Reference Standards

- A. American Iron and Steel Institute (AISI) Specification for the Design of Cold-Formed Steel Structural Members
- B. American National Standards Institute (ANSI) A137.1 American National Standard Specifications For Ceramic Tile
- C. American National Standards Institute (ANSI) A108.01 – A108.17 American National Standard Specifications For The Installation Of Ceramic Tile
- D. American National Standards Institute (ANSI) A118.1 – A118.12 American National Standard Specifications For The Installation Of Ceramic Tile
- E. American National Standards Institute (ANSI) A136.1 American National Standard Specifications For The Installation Of Ceramic Tile
- F. American Plywood Association (APA) Y510T Plywood Design Specifications
- G. American Society For Testing And Materials (ASTM) A82 Standard Specification for Steel Wire, Plain, for Concrete Reinforcement
- H. American Society For Testing And Materials (ASTM) A185 Standard Specification for Steel Welded Wire Fabric, Plain, for Concrete Reinforcement
- I. American Society For Testing And Materials (ASTM) C33 Standard Specification for Concrete Aggregate
- J. American Society For Testing And Materials (ASTM) C36 Standard Specification for Gypsum Wallboard
- K. American Society For Testing And Materials (ASTM) C109 Standard Test Method for Compressive Strength of Hydraulic Cement Mortars (Using 2" or 50 mm Cube Specimens)
- L. American Society For Testing And Materials (ASTM) C144 Standard Specification for Aggregate for Masonry Mortar
- M. American Society For Testing And Materials (ASTM) C150 Standard Specification for Portland Cement
- N. American Society For Testing And Materials (ASTM) C171 Standard Specification for Sheet Materials for Curing Concrete
- O. American Society For Testing And Materials (ASTM) C241 Standard Test Method for Abrasion Resistance of Stone Subjected to Foot Traffic
- P. American Society For Testing And Materials (ASTM) C267 Standard Test Method for Chemical Resistance of Mortars, Grouts, and Monolithic Surfacing
- Q. American Society For Testing And Materials (ASTM) C482 Standard Test Method for Bond Strength of Ceramic Tile to Portland Cement
- R. American Society For Testing And Materials (ASTM) C503 Standard Specification for Marble Dimension Stone (Exterior)
- S. American Society For Testing And Materials (ASTM) C531 Standard Test Method for Linear Shrinkage and Coefficient of Thermal Expansion of Chemical-Resistant Mortars, Grouts, Monolithic Surfacing and Polymer Concretes
- T. American Society For Testing And Materials (ASTM) C627 Standard Test Method for Evaluating Ceramic Floor Tile Installation Systems Using the Robinson-Type Floor Tester
- U. American Society For Testing And Materials (ASTM) C794 Standard Test Method for Adhesion-in-Peel of Elastomeric Joint Sealants
- V. American Society For Testing And Materials (ASTM) C847 Standard Specification for Metal Lath

- W. American Society For Testing And Materials (ASTM) C905 Standard Test Method for Apparent Density of Chemical-Resistant Mortars, Grouts, and Monolithic Surfacing
- X. American Society For Testing And Materials (ASTM) C920 Standard Specification for Elastomeric Joint Sealants
- Y. American Society For Testing And Materials (ASTM) C955 Standard Specification for Load Bearing (Transverse and Axial) Steel Studs, Runners (Tracks), and Bracing or Bridging for Screw Application of Gypsum Board and Metal Plaster Bases
- Z. American Society For Testing And Materials (ASTM) D226 Standard Specification for Asphalt-Saturated Organic Felt Used in Roofing And Waterproofing
- AA. American Society For Testing And Materials (ASTM) D227 Standard Specification for Coal-Tar Saturated Organic Felt Used in Roofing and Waterproofing
- BB. American Society For Testing And Materials (ASTM) D751 Standard Test Method for Coated Fabrics
- CC. American Society For Testing And Materials (ASTM) D751 Standard Test Method for Rubber Property – Durometer Hardness
- DD. American Society For Testing And Materials (ASTM) D1248 Standard Test Method for Staining of Porous Substances by Joint Sealants
- EE. American Society For Testing And Materials (ASTM) D2240 Standard Test Method for Coated Fabrics
- FF. American Society For Testing And Materials (ASTM) D4263 Standard Test Method for Indicating Moisture in Concrete by The Plastic Sheet Method
- GG. American Society For Testing And Materials (ASTM) D4397 Standard Specification for Polyethylene Sheeting for Construction, Industrial and Agricultural Applications
- HH. American Society For Testing And Materials (ASTM) D4716 Standard Test Method for Determining the (In Plane) Flow Rate Per Unit Width and Hydraulic Transmissivity of a Geo-Synthetic Using a Constant Head
- II. American Society For Testing And Materials (ASTM) E84 Standard Test Method for Surface Burning Characteristics of Building Materials
- JJ. American Society For Testing And Materials (ASTM) E90 Standard Test Method for Laboratory Measurement of Airborne Sound Transmission Loss of Building Partitions
- KK. American Society For Testing And Materials (ASTM) E96 Standard Test Methods for Water Vapor Transmission of Materials
- LL. American Society For Testing And Materials (ASTM) E413 Standard Classification for Rating Sound Insulation
- MM. American Society For Testing And Materials (ASTM) E492 Standard Test Method for Laboratory Measurement of Impact Sound Transmission Through Floor-Ceiling Assemblies Using the Tapping Machine
- NN. American Society For Testing And Materials (ASTM) E989 Standard Classification for Determination of Impact Insulation Class (IIC)
- OO. American Society of Mechanical Engineers (ASME) – ASME A112.6.3 Floor and Trench Drains
- PP. Canadian Sheet Steel Building Institute (CSSBI) Lightweight Steel Framing Binder {Publication 52M}
- QQ. Federal Housing Administration (FHA) Bulletin No. 750 Impact Noise Control in Multifamily Dwellings
- RR. Housing and Urban Development (HUD) TS 28 A Guide to Airborne, Impact and Structure-borne Noise-Control in Multifamily Dwellings

## Section 3: Part 1 – General Information

SS. Materials And Methods Standards Association (MMSA) Bulletins 1–16

TT. Metal Lath/Steel Framing Association (ML/SFA) 540 Lightweight Steel Framing Systems Manual

UU. Steel Stud Manufacturers Association (SSMA) Product Technical Information and ICBO Evaluation Service, Inc. Report ER-4943P

VV. Terrazzo, Tile And Marble Association Of Canada (TTMAC) Specification Guide 09300 Tile Installation Manual

WW. Tile Council Of North America (TCNA) Handbook For Ceramic Tile Installation

**NOTE TO SPECIFIER:** Edit for applicable reference standards.

### 1.10 System Description

A. Ceramic mosaic floor tile installed over concrete floor slabs using latex–modified Portland cement mortar and latex Portland cement grout joints.

B. Quarry tile and base installed using latex modified portland cement mortar over a plastic portland cement mortar bed or over a cured (pre-floated) Portland cement mortar bed with epoxy grouted joints.

**NOTE TO SPECIFIER:** The above systems are example descriptions; edit for additional applicable systems.

### 1.11 Submittals

**NOTE TO SPECIFIER:** Edit for applicable requirements.

A. Submittal Requirements: Submit the following “Required LEED Criteria” certification items as listed below. Refer to Division 1 for additional requirements:

1. A completed LEED Environmental Building Materials Certification Form. Information to be supplied generally includes:
  - a. Manufacturing plant locations for tile installation products.
  - b. LEED Credits as listed in Part 1.4B “LEED Credit Submittals”

c. GREENGUARD Environmental Institute certificates or GreenGuard Environmental Institute Schools & Children certificates provided by the tile installation materials manufacturer on GREENGUARD letterhead stating “This product has been GREENGUARD Indoor Air Quality Certified® by the GREENGUARD Environmental Institute under the GREENGUARD Standard for Low Emitting Products” for each tile installation product used to verify Low VOC product information.

2. Contractor’s certification of LEED Compliance: Submit Contractor’s certification verifying the installation of specified LEED Compliant products.
3. Product Cut Sheets for all materials that meet the LEED performance criteria. Submit Product Cut Sheets with Contractor or Subcontractor’s stamp, as confirmation that submitted products were installed on Project.
4. Material Safety Data Sheets for all applicable products.

B. LEED Credit Submittals for the following;

1. LEED Construction Guide for Green Building Design and Construction, 2009 Edition Credit EQ 4.1: Manufacturer’s product data for tile installation materials, including GREENGUARD Certificate on GREENGUARD letterhead stating product VOC content.
2. LEED Construction Guide for Green Building Design and Construction, 2009 Edition Credit EQ 4.3: Manufacturer’s product data for tile installation materials, including GREENGUARD Certificate on GREENGUARD letterhead stating product VOC content.
3. LEED Construction Guide for Green Building Design and Construction, 2009 Edition Credit MR 2.1: (Divert 50% from Disposal) Manufacturer’s packaging

- showing recycle symbol for appropriate disposition in construction waste management.
4. LEED Construction Guide for Green Building Design and Construction, 2009 Edition Credit MR 2.1: (Divert 75% from Disposal) Manufacturer's packaging showing recycle symbol for appropriate disposition in construction waste management.
  5. LEED Construction Guide for Green Building Design and Construction, 2009 Edition Credit MR 4.1: Manufacturer's product data showing post-consumer and/or pre-consumer recycled content.
  6. LEED Construction Guide for Green Building Design and Construction, 2009 Edition Credit MR 4.2: Manufacturer's product data showing post-consumer and/or pre-consumer recycled content.
  7. LEED Construction Guide for Green Building Design and Construction, 2009 Edition Credit MR 5.1 10% Extracted, Processed and Manufactured Regionally): Product data indicating location of material manufacturer for regionally manufactured materials.
    - a. Include statement indicating cost and distance from manufacturer to Project for each regionally manufactured product.
  8. LEED Construction Guide for Green Building Design and Construction, 2009 Edition Credit MR 5.2 (20% Extracted, Processed & Manufactured Regionally): Product data indicating location of material manufacturer for regionally manufactured materials.
    - a. Include statement indicating cost and distance from manufacturer to Project for each regionally manufactured product.
  9. LEED Schools Reference Guide (Educational Projects Only), 2007 Edition Credit EQ 9 (Enhanced Acoustical Performance): Impact noise reduction test reports and product data on sound control product(s).
  10. LEED Schools Reference Guide (Educational Projects Only), 2007 Edition Credit EQ 10 (Mold Prevention): Manufacturer's packaging and/or data showing anti-microbial protection in product(s).
- C. Submit shop drawings and manufacturers' product data under provisions of Section (01300) (01340)
  - D. Submit samples of each type/style/finish/size/color of ceramic tile, mosaic, paver, trim unit or threshold under provisions of Section (01300) (01340)
  - E. Submit manufacturers' installation instructions under provisions of Section (01300) (01340)
  - F. Submit manufacturer's certification under provisions of Section (01405) that the materials supplied conform to ANSI A137.1.
  - G. Submit proof of warranty.
  - H. Submit sample of installation system demonstrating compatibility/functional relationships between adhesives, mortars, grouts and other components under provision of Section (01300) (01340). Submit proof from tile or stone manufacturer or supplier verifying suitability of tile or stone for specific application and use; including dimensional stability, water absorption, freeze/thaw resistance (if applicable), resistance to thermal cycling, and other characteristics that the may project may require. These characteristics must be reviewed and approved by the project design professional(s).

- I. Submit list from manufacturer of installation system/adhesive/mortar/grout identifying a minimum of three (3) similar projects, each with a minimum of ten (10) years service.
- J. For alternate materials, at least thirty (30) days before bid date submit independent laboratory test results confirming compliance with specifications listed in Part 2 – Products.

### 1.12 Quality Assurance

- A. Tile Manufacturer (single source responsibility): Company specializing in ceramic tile, mosaics, pavers, trim units and/or thresholds with three (3) years minimum experience. Obtain tile from a single source with resources to provide products of consistent quality in appearance and physical properties.
- B. Installation System Manufacturer (single source responsibility): Company specializing in adhesives, mortars, grouts and other installation materials with ten (10) years minimum experience and ISO 9001 certification. Obtain installation materials from single source manufacturer to insure consistent quality and full compatibility.
- C. Submit laboratory confirmation of adhesives, mortars, grouts and other installation materials:
  - 1. Identify proper usage of specified materials using positive analytical method.
  - 2. Identify compatibility of specified materials using positive analytical method.
  - 3. Identify proper color matching of specified materials using a positive analytical method.
- D. Installer qualifications: company specializing in installation of ceramic tile, mosaics, pavers, trim units and thresholds with five (5) years documented experience with installations of similar scope, materials and design.

### 1.13 Mock-Ups

- A. Provide mock-up of each type/style/finish/size/color of ceramic tile, mosaics, pavers, trim unit and threshold, along with respective installation adhesives, mortars, grouts and other installation materials, under provisions of Section (01400) (01405).

### 1.14 Pre-Installation Conference

Pre-installation conference: At least three weeks prior to commencing the work attend a meeting at the job site to discuss conformance with requirements of specification and job site conditions. Representatives of owner, architect, general contractor, tile subcontractor, Tile Manufacturer, Installation System Manufacturer and any other parties who are involved in the scope of this installation must attend the meeting.

### 1.15 Delivery, Storage and Handling

- A. Acceptance at Site: deliver and store packaged materials in original containers with seals unbroken and labels, including grade seal, intact until time of use, in accordance with manufacturer's instructions.
- B. Store ceramic tile and installation system materials in a dry location; handle in a manner to prevent chipping, breakage, and contamination.
- C. Protect latex additives, organic adhesives, epoxy adhesives and sealants from freezing or overheating in accordance with manufacturer's instructions; store at room temperature when possible.
- D. Store portland cement mortars and grouts in a dry location.

### 1.16 Project/Site Conditions

- A. Provide ventilation and protection of environment as recommended by manufacturer.
- B. Prevent carbon dioxide damage to ceramic tile, mosaics, pavers, trim, thresholds, as well as adhesives, mortars, grouts and other installation materials, by venting temporary heaters to the exterior.

C. Maintain ambient temperatures not less than 50°F (10°C) or more than 100°F (38°C) during installation and for a minimum of seven (7) days after completion. Setting of portland cement is retarded by low temperatures. Protect work for extended period of time and from damage by other trades. Installation with latex portland cement mortars requires substrate, ambient and material temperatures at least 37°F (3°C). There should be no ice in slab. Freezing after installation will not damage latex portland cement mortars. Protect portland cement based mortars and grouts from direct sunlight, radiant heat, forced ventilation (heat and cold) and drafts until cured to prevent premature evaporation of moisture. Epoxy mortars and grouts require surface temperatures between 60°F (16°C) and 90°F (32°C) at time of installation. It is the General Contractor’s responsibility to maintain temperature control.

**1.17 Sequencing and Scheduling**

- A. Coordinate installation of tile work with related work.
- B. Proceed with tile work only after curbs, vents, drains, piping, and other projections through substrate have been installed and when substrate construction and framing of openings have been completed.

**NOTES FOR SPECIFIER:** Edit for project specific sequence and scheduling.

**1.18 Warranty**

The Contractor warrants the work of this Section to be in accordance with the Contract Documents and free from faults and defects in materials and workmanship for a period of 25 years. The manufacturer of adhesives, mortars, grouts and other installation materials shall provide a written twenty five (25) year warranty, which covers materials and labor – reference LATICRETE Warranty Data Sheet 025.0 for complete details and requirements. For exterior facades over steel or wood framing, the manufacturer of adhesives, mortars, grouts

and other installation materials shall provide a written ten (10) year warranty, which covers replacement of LATICRETE products only – reference LATICRETE Warranty Data Sheet 230.15 for complete details and requirements.

**1.19 Maintenance**

Submit maintenance data under provisions of Section 01730. Include cleaning methods, cleaning solutions recommended, stain removal methods, as well as polishes and waxes recommended.

**1.20 Extra Materials Stock**

Upon completion of the work of this Section, deliver to the Owner 2% minimum additional tile and trim shape of each type, color, pattern and size used in the Work, as well as extra stock of adhesives, mortars, grouts and other installation materials for the Owner’s use in replacement and maintenance. Extra stock is to be from same production run or batch as original tile and installation materials.

**PART 2 – PRODUCTS**

**2.1 Tile Manufacturers**

Subject to compliance with paragraphs 1.12 and performance requirements, provide products by one of the following manufacturers:

**NOTE TO SPECIFIER:** Provide list of acceptable tile manufacturers.

**2.2 Wall Tile Materials**

**NOTE TO SPECIFIER:** Edit for each tile type.

- A. Ceramic Tile
- B. Grade:
- C. Size:
- D. Edge
- E. Finish:
- F. Color
- G. Special shapes
- H. Location:

### 2.3 Floor Tile Materials

NOTE TO SPECIFIER: Edit for each tile type.

- A. Ceramic Tile
- B. Grade:
- C. Size:
- D. Edge
- E. Finish:
- F. Color
- G. Special shapes
- H. Location:

### 2.4 Ceramic Tile Installation Materials Manufacturer

- A. LATICRETE International, Inc.,  
1 LATICRETE Park North,  
Bethany, CT 06524-3423 USA  
Phone +1.800.243.4788, +1.203.393.0010  
support@laticrete.com,  
www.laticrete.com;  
www.laticrete.com/green

NOTE TO SPECIFIER: Use either the following performance specification or the proprietary specification.

### 2.5 Performance Specification –Tile Installation Accessories

- A. Waterproofing Membrane to be thin, cold applied, single component liquid and load bearing. Reinforcing fabric to be non-woven rot-proof specifically intended for waterproofing membrane. Waterproofing Membrane to be non-toxic, non-flammable, and non-hazardous during storage, mixing, application and when cured. It shall be certified by IAPMO and ICC approved as a shower pan liner and shall also meet the following physical requirements:
  - 1. Hydrostatic Test (ASTM D4068): Pass
  - 2. Elongation at break (ASTM D751): 20–30%
  - 3. System Crack Resistance (ANSI A118.12): Pass (High)
  - 4. 7 day Tensile Strength (ANSI A118.10): >265 psi (1.8 MPa)

- 5. 7 day Shear Bond Strength (ANSI A118.10) >200 psi (1.4 MPa)
- 6. 28 Day Shear Bond Strength (ANSI A118.4): >214 psi (1.48 – 2.4 MPa)
- 7. Service Rating (TCA/ASTM C627): Extra Heavy
- 8. Total VOC Content: <0.05 mg/m<sup>3</sup>

- B. Epoxy Waterproofing Membrane to be 3 component epoxy, trowel applied specifically designed to be used under ceramic tile, stone or brick and requires only 24 hours prior to flood testing:

- 1. Breaking Strength (ANSI A118.10): 450–530 psi (3.1–3.6 MPa)
- 2. Waterproofness (ANSI A118.10): No Water penetration
- 3. 7 day Shear Bond Strength (ANSI A118.10): 110–150 psi (0.8–1 MPa)
- 4. 28 Day Shear Bond Strength (ANSI A118.10): 90–120 psi (0.6–0.83 MPa)
- 5. 12 Week Shear Bond Strength (ANSI A118.10): 110–130 psi (0.8–0.9 MPa)
- 6. Total VOC Content: <3.4 g/l

- C. Crack Suppression Membrane to be thin, cold applied, single component liquid and load bearing. Reinforcing fabric (if required or used) to be non-woven, rot-proof specifically intended for crack suppression membrane. Materials to be non-toxic, non-flammable, and non-hazardous during storage, mixing, application and when cured. Crack Suppression Membrane shall also meet the following physical requirements:

- 1. Elongation at break (ASTM D751): 20–30%
- 2. System Crack Resistance (ANSI A118.12) Pass (High)
- 3. 7 day Tensile Strength (ANSI A118.10): 265 – 300 psi (1.8 – 2.0 MPa)
- 4. 7 day Shear Bond Strength (ANSI A118.10) 200 – 275 psi (1.4 – 1.9 MPa)



- 5. 28 Day Shear Bond Strength (ANSI A118.4): >214 – 343 psi (1.48 – 2.4 MPa)
- 6. Service Rating (TCA/ASTM C627): Extra Heavy
- 7. Total VOC Content: <0.05 mg/m<sup>3</sup>
- D. Wire Reinforcing: 2" x 2" (50 x 50 mm) x 16 ASW gauge or 0.0625" (1.6 mm) diameter galvanized steel welded wire mesh complying with ANSI A108.02 3.7, ASTM A185 and ASTM A82.
- E. Cleavage membrane: 15 pound asphalt saturated, non-perforated roofing felt complying with ASTM D226, 15 pound coal tar saturated, non-perforated roofing felt complying with ASTM D227 or 4.0 mils (0.1 mm) thick polyethylene plastic film complying with ASTM D4397.
- F. Cementitious backer board units: size and thickness as specified, complying with ANSI A118.9.
- G. Thresholds: Provide marble saddles complying with ASTM C241 for abrasion resistance and ASTM C503 for exterior use, in color, size, shape and thickness as indicated on drawings.

**NOTE TO SPECIFIER:** Edit applicable tile installation accessories.

## 2.6 Performance Specification – Tile Installation Materials

- A. Sound Abatement & Crack Isolation Mat shall be load bearing, shock and vibration resistant. It shall be certified by independent laboratory testing to meet the specified acoustical performance when installed in a Floor Assembly with a 6" (150 mm) concrete slab, as well as meet the following physical requirements:
  - 1. Service Rating (ASTM C627): Light
  - 2. Point Load (ANSI A118.12–5.2): >1250 psi (8.6 MPa)
  - 3. Installed Weight (ASTM C905 Modified): 2.6 lbs/ft<sup>2</sup> (12.8 kg/m<sup>2</sup>)
  - 4. Delta Impact Insulation Class (ΔIIC; ASTM E2179): 20
- B. Sound Abatement and Crack Suppression Adhesive shall comply with ANSI A118.12, provide an Extra Heavy rating and provide a minimum ΔIIC of 15:
  - 1. Service Rating (ASTM C627): Extra Heavy
  - 2. Delta Impact Insulation Class (ΔIIC; ASTM E2179): 15
  - 3. Point Load (ANSI A118.12 5.2): >1000 psi (6.9 MPa)
  - 4. Minimum Shear Bond Strength (ANSI A118.12): 100psi (0.7 MPa)
- C. Moisture Vapor Reduction to be epoxy based and GreenGuard compliant as well as meet the following physical requirements:
  - 1. Shear Bond to Concrete (ANSI A118.12–5.1.5): >285 psi (2.0 MPa)
  - 2. Alkalinity Resistance (ASTM C267): Pass
  - 3. Permeability (ASTM F1869): 9.7 lbs/1,000 ft<sup>2</sup>/24 hours down to 0.2 lbs/1,000 ft<sup>2</sup>/24 hours (248 μg/s•m<sup>2</sup> down to 11 μg/s•m<sup>2</sup>)
- D. Latex Portland Cement Mortar for thick beds, screeds, leveling beds and scratch/plaster coats to be weather, frost, shock resistant and meet the following physical requirements:
  - 1. Compressive Strength (ANSI A118.4 Modified): >4000 psi (27.6 MPa)
  - 2. Water Absorption (ANSI A118.6): ≤ 5%
  - 3. Service Rating (TCA/ASTM C627): Extra Heavy
  - 4. Smoke and Flame Contribution (ASTM E84 Modified): 0
  - 5. Total VOC Content: <0.05 mg/m<sup>3</sup>
- E. Self-Leveling Underlayment shall be mixed with water to produce a pumpable, fast setting, free flowing cementitious underlayment which can be poured from a feather-edge to 1-1/2" (38 mm) thick in one pour.

## Section 3: Part 3 – Execution Statement

- 4 Hour Compressive Strength (ANSI A118.4 Mod.): >1500 psi (10.3 MPa)
  - 1 Day Compressive Strength (ANSI A118.4 Mod.): >2800 psi (19.3 MPa)
  - 28 Day Compressive Strength (ANSI A118.4 Mod.): >4300 psi (29.7 MPa)
  - Tensile Strength (ANSI A118.7): >500 psi (3.5 MPa)
  - Time To Foot Traffic: 3 – 4 Hours
  - otal VOC Content: <0.05 mg/m<sup>3</sup>
- F. Epoxy Adhesive to be chemical resistant 100% solids epoxy with high temperature resistance and meet the following minimum physical requirements:
- Compressive strength (ANSI A118.3): >5000 psi (34.4 MPa)
  - Shear Bond Strength (ANSI A118.3): >1250 psi (8.6 MPa)
  - Thermal Shock Resistance (ANSI A118.3): >600 psi (4.1 MPa)
  - Tensile Strength (ANSI A118.3): >1400 psi (9.6 MPa)
  - Shrinkage (ANSI A118.3): 0 – 0.1%
  - Total VOC Content: <0.05 mg/m<sup>3</sup>
  - Cured Epoxy Adhesive to be chemically and stain resistant to ketchup, mustard, tea, coffee, milk, soda, beer, wine, bleach (5% solution), ammonia, juices, vegetable oil, detergents, brine, sugar, cosmetics and blood, as well as chemically resistant to dilute food acids, dilute alkalis, gasoline, turpentine and mineral spirits.
- G. Latex Portland Cement Thin Bed Mortar for thin set and slurry bond coats to be weather, frost, shock resistant, non-flammable and meet the following physical requirements:
- Compressive strength (ANSI A118.4): >2500 psi (17.2 MPa)
  - Bond strength (ANSI A118.4): >450 psi (3.1 MPa)
  - Smoke and Flame Contribution (ASTM E84 Modified): 0
  - Total VOC Content: <0.05 mg/m<sup>3</sup>
- H. Organic Adhesive shall be non-flammable, water resistant, latex adhesive and shall meet the following physical requirements:
- Open Time (ANSI A136.1): 70 minutes at 75°F (24°C)
  - Color: White
  - Density (ANSI A136.1): 13.2 lbs/gal (1.6 kg/l)
- I. Epoxy Grout (Industrial) to be non-flammable, chemical resistant 100% solids epoxy with high temperature resistance and meeting the following physical requirements:
- Initial Set Time (ANSI A118.5): Pass (4 hours)
  - Service Set Time (ANSI A118.5): Pass (<7 days)
  - Shrinkage (ANSI A118.3): Pass (0.07%)
  - Sag (ANSI A118.3): Pass (no sag)
  - Shear Bond Strength (ANSI A118.3; quarry tile): 1000 psi (6.9 MPa)
  - Compressive Strength (ANSI A118.3): 15500 psi (107 MPa)
  - Tensile Strength (ANSI A118.5): 2600 psi (18.0 MPa)
  - Thermal Shock Resistance (ANSI A118.3): 500 psi (3.4 MPa)
  - Cured Epoxy Grout to be chemically and stain resistant to ketchup, mustard, tea, coffee, milk, soda, beer, wine, bleach (3% solution), ammonia, juices, vegetable oil, detergents, brine, sugar, cosmetics and blood, as well as being chemically resistant to dilute food/mineral acids, gasoline and mineral spirits.
- J. Epoxy Grout (Commercial/Residential) shall be non-toxic, non-flammable, non-hazardous during storage, mixing, application and when cured and shall meet the following physical requirements:

1. Compressive Strength (ANSI A118.3): 3500 psi (24 MPa)
  2. Shear Bond Strength (ANSI A118.3): 1000 psi (6.9 MPa)
  3. Tensile Strength (ANSI A118.3): 1100 psi (7.6 MPa)
  4. Thermal Shock (ANSI A118.3): >500 psi (3.5 MPa)
  5. Water Absorption (ANSI A118.3): <0.5 %
  6. Vertical Joint Sag (ANSI A118.3): Pass
  7. Total VOC Content: <0.05 mg/m<sup>3</sup>
  8. Cured Epoxy Grout to be chemically and stain resistant to ketchup, mustard, tea, coffee, milk, soda, beer, wine, bleach (5% solution), ammonia, juices, vegetable oil, brine, sugar, cosmetics, and blood, as well as chemically resistant to dilute acids and dilute alkalis.
- K. Latex Portland Cement Grout to be weather, frost and shock resistant, as well as meet the following physical requirements:
1. Compressive Strength (ANSI A118.7): 4500 psi (31 MPa)
  2. Tensile Strength (ANSI A118.7): >500 psi (3.45 MPa)
  3. Flexural Strength (ANSI A118.7): >1250 psi (8.6 MPa)
  4. Water Absorption (ANSI A118.7): <5%
  5. Linear Shrinkage (ANSI A118.7): <0.05 %
  6. Smoke and Flame Contribution (ASTM E84 Modified): 0
  7. Total VOC Content: <0.05 mg/m<sup>3</sup>
- L. Expansion and Control Joint Sealant to be a one component, neutral cure, exterior grade silicone sealant and meet the following requirements:
1. Tensile Strength (ASTM C794): 280 psi (1.9 MPa)
    - a. Hardness (ASTM D751; Shore A): 25 (colored sealant)/15 (clear sealant)
2. Weather Resistance (QUV Weatherometer): 10000 hours (no change)
- M. Roof Decks (and other exterior paving applications over occupied / storage spaces) shall consist of a Primary Roofing/Waterproofing Membrane, as specified in Section 0700 (q.v.), and a lightweight, frost/weather resistant installation system for tile, pavers, brick and stone that provides integral subsurface drainage and meets the following physical requirements:
1. Compressive Strength (ASTM C109 Modified): 3000 psi (20.7 MPa)
  2. Hydraulic Transmissivity (ASTM D4716): 1.6 gal/minute (6.1 l/minute)
  3. Service Rating (ASTM C627): Extra Heavy
- N. Spot Bonding Epoxy Adhesive for installing tile, brick and stone over vertical and overhead surfaces shall be high strength, high temperature resistant, non-sag and shall meet the following physical requirements:
1. Thermal Shock Resistance (ANSI A118.3): >1000 psi (6.9 MPa)
  2. Water Absorption (ANSI A118.3): 0.1 %
  3. Compressive Strength (ANSI A118.3): >8300 psi (57.2 MPa)
  4. Shear Bond Strength (ANSI A118.3 Modified): >730 psi (5 MPa)

**NOTE TO SPECIFIER:** Edit applicable tile installation materials.

### 2.7 Proprietary Specification – Tile Installation Accessories

Installation accessories as manufactured by LATICRETE International, Inc.,  
 1 LATICRETE Park North,  
 Bethany, CT 06524-3423 USA.  
 Phone +1.800.243.4788,  
 www.laticrete.com

- A. Waterproofing Membrane: LATICRETE® Hydro Ban™\*\*\* as manufactured by LATICRETE International, Inc.

## Section 3: Part 3 – Execution Statement

B. Epoxy Waterproofing Membrane: LATAPOXY® 24hr HydroProofing™ as manufactured by LATICRETE International, Inc.

C. Crack Suppression Membrane: LATICRETE® Blue 92 Anti-Fracture Membrane\*\* as manufactured by LATICRETE International, Inc.

**NOTE TO SPECIFIER:** Edit applicable tile installation accessories.

### 2.8 Proprietary Specification – Tile Installation Materials

Installation materials as manufactured by LATICRETE International, Inc.,

1 LATICRETE Park North,

Bethany, CT 06524-3423 USA.

Phone +1.800.243.4788,

www.laticrete.com; www.laticrete.com/green

A. Sound Control Underlayment: LATICRETE 170 Sound & Crack Isolation Mat (Standard or PLUS Configurations) as manufactured by LATICRETE International, Inc.

B. Latex-Portland Cement Mortar for thick beds, screeds, leveling beds and scratch/plaster coats: LATICRETE 3701 Fortified Mortar Bed\*\* as manufactured by LATICRETE International, Inc.

C. Self-Leveling Underlayment: LATICRETE 86 Latilevel™\*\* as manufactured by LATICRETE International, Inc.

D. Moisture Vapor Reduction: LATAPOXY 312 Vapor Reduction Membrane\*\* as manufactured by LATICRETE International, Inc.

E. Epoxy Adhesive: LATAPOXY 300 Adhesive\*\* as manufactured by LATICRETE International, Inc.

F. Latex Portland Cement Thin Bed Mortar: LATICRETE 254 Platinum\*\* as manufactured by LATICRETE International, Inc.

G. Sound & Crack Isolation Adhesive: LATICRETE 125 Sound & Crack Adhesive^\*\* as manufactured by LATICRETE International, Inc.

H. Organic Adhesive: LATICRETE 15 Premium Mastic as manufactured by LATICRETE International, Inc.

I. Epoxy Grout (Industrial): LATAPOXY 2000 Industrial Grout\*\* as manufactured by LATICRETE International, Inc.

J. Epoxy Grout (Commercial/Residential): LATICRETE SpectraLOCK® PRO Grout\*\*\* as manufactured by LATICRETE International, Inc.

K. Latex Portland Cement Grout: LATICRETE PermaColor™ Grout\*\* as manufactured by LATICRETE International, Inc.

L. Expansion and Control Joint Sealant: LATICRETE LataSil™ as manufactured by LATICRETE International, Inc.

M. Roof Deck: LATICRETE Plaza & Deck System as manufactured by LATICRETE International, Inc.

N. Spot Bonding Epoxy Adhesive: LATAPOXY 310 Stone Adhesive (Standard or Rapid Grade) as manufactured by LATICRETE International, Inc.

## PART 3 – EXECUTION

### 3.1 Substrate Examination

A. Verify that surfaces to be covered with ceramic tile, mosaics, pavers, brick, stone, trim or waterproofing are:

1. Sound, rigid and conform to good design/engineering practices;
2. Systems, including the framing system and panels, over which tile or stone will be installed shall be in conformance with the International Residential Code (IRC) for residential applications, the International Building Code (IBC) for commercial applications, or applicable building codes. The project design should include the intended use and necessary allowances for the expected live load, concentrated load, impact load, and dead load including the weight of the finish and installation materials;

3. Clean and free of dust, dirt, oil, grease, sealers, curing compounds, laitance, efflorescence, form oil, loose plaster, paint, and scale;
  4. Thin-set tile installations have a specified subsurface tolerance, for instance 1/4" in 10' (6 mm in 3 m) and 1/16" in 1' (1.5 mm in 300 mm), to conform with the ANSI specifications. Because thin-set is not intended to be used in truing or leveling the work of others, the subsurface typically should not vary by more than 1/16" over 1' (1.5 mm over 300 mm), nor more than 1/32" (0.8 mm) between adjoining edges where applicable (e.g. between sheets of exterior glue plywood or between adjacent concrete masonry units). Should the architect/designer require a more stringent tolerance (e.g. 1/8" in 10' [3 mm in 3 m]), the subsurface specification must reflect that tolerance, or the tile specification must include a specific and separate requirement to bring the 1/4" (6 mm) subsurface tolerance into compliance with the 1/8" (6 mm) tolerance desired;
  5. Not leveled with gypsum or asphalt based compounds;
  6. Dry as per American Society for Testing and Materials (ASTM) D4263 "Standard Test for Determining Moisture in Concrete by the Plastic Sheet Method."
- B. Concrete surfaces shall also be:
1. Cured a minimum of 28 days at 70°F (21°C), including an initial seven (7) day period of wet curing;
- NOTE TO SPECIFIER: LATICRETE® latex portland cement mortars do not require a minimum cure time for concrete substrates or mortar beds;**
2. Wood float finished, or better, if the installation is to be done by the thin bed method;
- C. Advise General Contractor and Architect of any surface or substrate conditions requiring correction before tile work commences. Beginning of work constitutes acceptance of substrate or surface conditions.

### 3.2 Surface Preparation

#### A. Requirements

Steam Rooms require a waterproofing membrane on all surfaces to prevent moisture from penetrating adjoining spaces. Additionally, a vapor barrier (6 mil thick polyethylene sheeting or #15 Builders Felt) must be installed over the steel framing and behind the cement backer board. Vapor barrier shall be designed for relative temperature exposure. Install vapor barrier so that it laps over the shower pan waterproofing membrane so that condensation can drain into the shower pan (not behind it) – see associated detail SR-614B. All steam rooms will require adequate insulation on walls and ceilings to reduce moisture condensation at temperature variations. Slope ceilings 2" per foot (50 mm per 300 mm) minimum to avoid condensation from dripping onto occupants. Install open slip joints in all corners between walls and ceiling and to divide areas that exceed 16' (480 cm) in length.

Structure to receive the installation assembly must be sound, solid, well bonded, stripped clean and free from dust, wax, grease, sealer and all other contamination which may reduce or prevent adhesion per ANSI A108.02 (4.0).

B. Bonded Thick Bed – Pitch Layer Over Floor Substrate – To provide pitch over a concrete deck, prepare a LATICRETE Latex Leveling Bed mix (see § 3.4 C thick bed mortar material below applied over a slurry bond coat consisting of LATICRETE 254 Platinum). Apply mortar over dampened substrate. Pitch layer 1/4" per 1' (6 mm per 0.3 m) per ANSI A108.1A (2.3.4).

C. (List other Substrates as required and means of preparation as required)

(Insert any Special Means of Preparation – In addition to the surface preparation requirements listed above; ...)

**NOTE TO SPECIFIER:** The above are example surface categories; edit for project specific surfaces and conditions.

### 3.3 Installation – Accessories

(edit as required)

### 3.4 Installation – Tile, Brick and Stone

A. General: Install in accordance with current versions of American National Standards Institute, Inc. (ANSI) “A108 American National Standard Specifications for Installation of Ceramic Tile” and TCNA “Handbook for Ceramic Tile Installation.” Cut and fit ceramic tile, brick or stone neatly around corners, fittings, and obstructions. Perimeter pieces to be minimum half tile, brick or stone. Chipped, cracked, split pieces and edges are not acceptable. Make joints even, straight, plumb and of uniform width to tolerance  $\pm 1/16$ " over 8' (1.5 mm in 2.4 m). Install divider strips at junction of flooring and dissimilar materials.

B. Waterproofing Membrane installed over pre-sloped floor substrate and all walls and ceilings. Membrane must be used on all areas in the steam room. Loop membrane into all slip joints to allow for movement in these areas.

**NOTE TO SPECIFIER:** Adhesives/mastics, mortars and grouts for ceramic tile, mosaics, pavers, brick and stone are not replacements for waterproofing membranes and will not prevent water penetration into occupied or storage spaces below. Drains must be a two-part clamping ring style drains with weepers and as per ASME A112.6.3. Place tile spacers or gravel around weep holes to prevent mortar from clogging the weep holes.

Install the waterproofing membrane in compliance with current revisions of ANSI A108.1 (2.7 Waterproofing) and ANSI A108.13. Review the installation and plan the application sequence. Pre-cut LATICRETE® Waterproofing/Anti-Fracture Fabric (if required), allowing 2"

(50 mm) for overlap at ends and sides to fit the areas as required. Roll up the pieces for easy handling and placement. Shake or stir LATICRETE Hydro Ban™ before using.

**Pre-Treat Cracks and Joints** – Fill all substrate cracks, cold joints and control joints to a smooth finish using a LATICRETE latex-fortified thin-set. Alternatively, a liberal coat\* of LATICRETE Hydro Ban applied with a paint brush or trowel may be used to fill in non-structural joints and cracks. Apply a liberal coat\* of LATICRETE Hydro Ban approximately 8" (200 mm) wide over substrate cracks, cold joints, and control joints using a paint brush or heavy napped paint roller.

**Pre-Treat Coves and Floor/Wall Intersections** – Fill all substrate coves and floor/wall transitions to a smooth finish and changes in plane using a LATICRETE latex-fortified thin-set. Alternatively, a liberal coat\* of LATICRETE Hydro Ban™ applied with a paint brush or trowel may be used to fill in cove joints and floor/wall transitions  $< 1/8$ " (3 mm) in width. Apply a liberal coat\* of LATICRETE Hydro Ban approximately 8" (200 mm) wide over substrate cracks, cold joints, and control joints using a paint brush or heavy napped paint roller.

**Pre-Treat Drains** – Drains must be of the clamping ring type, with weepers as per ASME A112.6.3. Apply a liberal coat\* of LATICRETE Hydro Ban around and over the bottom half of drain clamping ring. Cover with a second liberal coat of LATICRETE Hydro Ban. When the LATICRETE Hydro Ban dries, apply a bead of LATICRETE Latasil™ where the LATICRETE Hydro Ban meets the drain throat. Install the top half of drain clamping ring.

**Pre-Treat Penetrations** – Allow for a minimum  $1/8$ " (3 mm) space between drains, pipes, lights, or other penetrations and surrounding ceramic tile, stone or brick. Pack any gaps around pipes, lights or other penetrations with a LATICRETE latex-fortified thin-set. Apply a liberal coat\* of LATICRETE Hydro Ban around

penetration opening. Cover the first coat with a second liberal coat\* of LATICRETE Hydro Ban. Bring LATICRETE Hydro Ban up to level of tile or stone. When LATICRETE Hydro Ban has dried to the touch seal with LATICRETE Latasil.

**Main Application** – Allow any pre-treated areas to dry to the touch. Apply a liberal coat\* of LATICRETE Hydro Ban with a paint brush or heavy napped roller over substrate including pre-treated areas and allow to dry to the touch. Install another liberal coat\* of LATICRETE Hydro Ban over the first coat. Let the top coat of LATICRETE Hydro Ban dry to the touch approximately 1 – 2 hours at 70°F (21°C) and 50% RH. When the top coat has dried to the touch inspect the surface for pinholes, voids, thin spots or other defects. LATICRETE Hydro Ban will dry to an olive green color when fully cured. Use additional LATICRETE Hydro Ban to seal any defects.

**Movement Joints** – Apply a liberal coat\* of LATICRETE Hydro Ban, approximately 8" (200 mm) wide over the areas. Then embed and loop the 6" (150 mm) wide LATICRETE Waterproofing/Anti-Fracture Fabric and allow the LATICRETE Hydro Ban liquid to bleed through. Immediately apply a second coat of LATICRETE Hydro Ban.

\* Dry coat thickness is 20 – 30 mil (0.02 – 0.03" or 0.5 – 0.8 mm); consumption per coat is approximately 0.01 gal/ft<sup>2</sup> (approx. 0.4 l/m<sup>2</sup>); coverage is approximately 100 ft<sup>2</sup>/gal (approx. 2.5 m<sup>2</sup>/l). LATICRETE® Waterproofing/Anti-Fracture Fabric can be used to pre-treat cracks, joints, curves, corners, drains, and penetrations with LATICRETE Hydro Ban™.

**Protection** – Provide protection for newly installed membrane, even if covered with a thin-bed ceramic tile, stone or brick installation against exposure to rain or other water for a minimum of 2 hours at 70°F (21°C) and 50% RH. For temperatures between 45°F and 69°F (7°C to 21°C) allow a minimum 24 hour cure period.

**Flood Testing** – Allow membrane to cure fully before flood testing, typically a minimum 2 hours at 70°F (21°C) and 50% RH. Cold

conditions will require a longer curing time. For temperatures between 50°F and 69°F (10°C to 21°C) allow a minimum 24 hour cure period prior to flood testing.

**Use the following LATICRETE® System Materials**  
LATICRETE Hydro Ban

### References

LATICRETE Data Sheets: 663.0, 663.5

LATICRETE MSDS: Hydro Ban, Fabric

GREENGUARD Certificate: Hydro Ban

LATICRETE Technical Data Sheets: 188, 189, 203, 169

C. Bonded Thick Bed Method: Apply a slurry bond coat consisting of LATICRETE® 254 Platinum. Apply mortar over dampened substrate. Pitch layer 1/4" per 1' (6 mm per 300 mm) to comply with ANSI A108.1A (2.3.4). While slurry bond coat is wet and tacky, embed the mortar bed consisting of LATICRETE 3701 Fortified Mortar Bed mixed with water in compliance with current revision of ANSI A108.1A (2.2 and 5.2) and compact mortar by tamping with flat trowel. Screed mortar bed level and provide correct slopes to drains.

**Use the following LATICRETE System Materials**

LATICRETE 3701 Fortified Mortar Bed

LATICRETE 254 Platinum

### References

LATICRETE Data Sheets: 100.0; 677.0

LATICRETE MSDS: 3701FMB; 254

GREENGUARD Certificates: 3701FMB; 254

LATICRETE Technical Data Sheets: 106, 114, 118, 128, 143, 154, 199, 204

D. Secondary Waterproofing Membrane installed over cured mortar bed on the floor surfaces and turned up the vertical surfaces at least 6" (150 mm) onto the existing waterproofing membrane. Loop membrane into all slip and movement joints to allow for movement in these areas.

## Section 3: Part 3 – Execution Statement

**NOTE TO SPECIFIER:** Adhesives/mastics, mortars and grouts for ceramic tile, mosaics, pavers, brick and stone are not replacements for waterproofing membranes and will not prevent water penetration into occupied or storage spaces below.

Install the waterproofing membrane in compliance with current revisions of ANSI A108.1 (2.7 Waterproofing) and ANSI A108.13. Review the installation and plan the application sequence. Pre-cut LATICRETE® Waterproofing/Anti-Fracture Fabric (if required), allowing 2" (50 mm) for overlap at ends and sides to fit the areas as required. Roll up the pieces for easy handling and placement. Shake or stir LATICRETE Hydro Ban™ before using.

**Pre-Treat Cracks and Joints** – Fill all substrate cracks, cold joints and control joints to a smooth finish using a LATICRETE latex-fortified thin-set. Alternatively, a liberal coat\* of LATICRETE Hydro Ban applied with a paint brush or trowel may be used to fill in non-structural joints and cracks. Apply a liberal coat\* of LATICRETE Hydro Ban approximately 8" (200 mm) wide over substrate cracks, cold joints, and control joints using a paint brush or heavy napped paint roller.

**Pre-Treat Coves and Floor/Wall Intersections** – Fill all substrate coves and floor/wall transitions to a smooth finish and changes in plane using a LATICRETE latex-fortified thin-set. Alternatively, a liberal coat\* of LATICRETE Hydro Ban™ applied with a paint brush or trowel may be used to fill in cove joints and floor/wall transitions <1/8" (3 mm) in width. Apply a liberal coat\* of LATICRETE Hydro Ban approximately 8" (200 mm) wide over substrate cracks, cold joints, and control joints using a paint brush or heavy napped paint roller.

**Pre-Treat Drains** – Drains must be of the clamping ring type, with weepers as per ASME A112.6.3. Apply a liberal coat\* of LATICRETE Hydro Ban™ around and over the bottom half of drain clamping ring. Cover with a second liberal coat of LATICRETE Hydro Ban. When the LATICRETE Hydro Ban dries, apply a bead

of LATICRETE Latasil™ where the LATICRETE Hydro Ban meets the drain throat. Install the top half of drain clamping ring.

**Pre-Treat Penetrations** – Allow for a minimum 1/8" (3 mm) space between drains, pipes, lights, or other penetrations and surrounding ceramic tile, stone or brick. Pack any gaps around pipes, lights or other penetrations with a LATICRETE latex-fortified thin-set. Apply a liberal coat\* of LATICRETE Hydro Ban around penetration opening. Cover the first coat with a second liberal coat\* of LATICRETE Hydro Ban. Bring LATICRETE Hydro Ban up to level of tile or stone. When LATICRETE Hydro Ban has dried to the touch seal with LATICRETE Latasil.

**Main Application** – Allow any pre-treated areas to dry to the touch. Apply a liberal coat\* of LATICRETE Hydro Ban with a paint brush or heavy napped roller over substrate including pre-treated areas and allow to dry to the touch. Install another liberal coat\* of LATICRETE Hydro Ban over the first coat. Let the top coat of LATICRETE Hydro Ban dry to the touch approximately 1 – 2 hours at 70°F (21°C) and 50% RH. When the top coat has dried to the touch inspect the surface for pinholes, voids, thin spots or other defects. LATICRETE Hydro Ban will dry to an olive green color when fully cured. Use additional LATICRETE Hydro Ban to seal any defects.

**Movement Joints** – Apply a liberal coat\* of LATICRETE Hydro Ban, approximately 8" (200 mm) wide over the areas. Then embed and loop the 6" (150 mm) wide LATICRETE Waterproofing/Anti-Fracture Fabric and allow the LATICRETE Hydro Ban liquid to bleed through. Immediately apply a second coat of LATICRETE Hydro Ban.

\* Dry coat thickness is 20 – 30 mil (0.02 – 0.03" or 0.5 – 0.8 mm); consumption per coat is approximately 0.01 gal/ft<sup>2</sup> (approx. 0.4 l/m<sup>2</sup>); coverage is approximately 100 ft<sup>2</sup>/gal (approx. 2.5 m<sup>2</sup>/l). LATICRETE® Waterproofing/Anti-Fracture Fabric can be used to pre-treat cracks, joints, curves, corners, drains, and penetrations with LATICRETE Hydro Ban™.



**Protection** – Provide protection for newly installed membrane, even if covered with a thin-bed ceramic tile, stone or brick installation against exposure to rain or other water for a minimum of 2 hours at 70°F (21°C) and 50% RH. For temperatures between 45°F and 69°F (7°C to 21°C) allow a minimum 24 hour cure period.

**Flood Testing** – Allow membrane to cure fully before flood testing, typically a minimum 2 hours at 70°F (21°C) and 50% RH. Cold conditions will require a longer curing time. For temperatures between 50°F and 69°F (10°C to 21°C) allow a minimum 24 hour cure period prior to flood testing.

**Use the following LATICRETE® System Materials**  
LATICRETE Hydro Ban

### References

LATICRETE Data Sheets: 663.0, 663.5

LATICRETE MSDS: Hydro Ban, Fabric

GREENGUARD Certificate: Hydro Ban

LATICRETE Technical Data Sheets: 188, 189, 203

E. Thin Bed Method: Install latex portland cement mortar in compliance with current revisions of ANSI A108.02 (3.8 Membrane or cleavage membrane), A108.1B and ANSI A108.5. Use the appropriate trowel notch size to ensure proper bedding of the tile, brick or stone selected. Work the latex portland cement mortar into good contact with the substrate and comb with notched side of trowel. Spread only as much latex portland cement mortar as can be covered while the mortar surface is still wet and tacky. When installing large format (>8" x 8"/200 mm x 200 mm) tile/stone, rib/button/lug back tiles, pavers or sheet mounted ceramics/mosaics, spread latex portland cement mortar onto the back of (i.e. 'back-butter') each piece/sheet in addition to trowelling latex portland cement mortar over the substrate. Beat each piece/sheet into the latex portland cement mortar with a beating block or rubber mallet to insure full bedding and flatness. Allow installation

to set until firm. Clean excess latex portland cement mortar from tile or stone face and joints between pieces.

**Use the following LATICRETE System Materials**

LATICRETE 254 Platinum

### References

LATICRETE Data Sheet: 677.0

LATICRETE MSDS: 254

GREENGUARD Certificate: 254

LATICRETE Technical Data Sheets: 105, 118, 126, 129, 199, 209

F. Grouting or Pointing:

**NOTE TO SPECIFIER:** Select one of following and specify color for each type/color of ceramic tile, mosaic, paver, trim unit:

1. Chemical Resistant, Water Cleanable Tile-Grouting Epoxy (ANSI A118.3): Follow manufacturer's recommendations for minimum cure time prior to grouting. Store liquid components of LATICRETE SpectraLOCK® PRO Grout† for 24 hours at 70–80°F (21–27°C) prior to use to facilitate mixing and application. Substrate temperature must be 40–95°F (4–35°C). Verify joints are free of dirt, debris or grout spacers. Sponge or wipe dust/dirt off tile faces and remove water standing in joints. Apply grout release to face of absorptive, abrasive, non-slip or rough textured ceramic tile, pavers, bricks, stone or trim units that are not hot paraffin coated to facilitate cleaning. Cut open pouch and pour LATICRETE SpectraLOCK PRO Grout Part A Liquid into a clean mixing pail. Then open pouch and pour LATICRETE SpectraLOCK PRO Grout Part B Liquid into the mixing pail. Mix by hand or with a slow speed (<300 rpm) mixer until the two liquids are well blended. Then, while mixing, add LATICRETE SpectraLOCK PRO Grout Part C Powder and blend until uniform. Install LATICRETE SpectraLOCK PRO Grout in compliance with current revisions of ANSI A108.02 (3.13) and ANSI A108.6 (3.0 – 4.0). Spread using a sharp

edged, hard rubber float and work grout into joints. Using strokes diagonal (at 45° angle) to the grout lines, pack joints full and free of voids/pits. Then hold float face at a 90° angle to grouted surface and use float edge to “squeegee” off excess grout, stroking diagonally to avoid pulling grout out of filled joints. Once excess grout is removed, a thin film/haze will be left. Initial cleaning of the remaining film/haze can begin approximately 20–30 minutes after grouting (wait longer at colder temperatures). Begin by mixing cleaning additive packet with 2 gallons (7.6 l) of clean water in a clean bucket to make cleaning solution. Dip a clean sponge into the bucket and then wring out cleaning solution until sponge is damp. Using a circular motion, lightly scrub grouted surfaces with the damp sponge to dissolve grout film/haze. Then drag sponge diagonally over the scrubbed surfaces to remove froth. Rinse sponge frequently and change cleaning solution at least every 50 ft<sup>2</sup> (4.7m<sup>2</sup>). Discard sponges as they become “gummy” with residue. Within one (1) hour of finishing first cleaning, clean the same area again following the same procedure but utilizing a clean white scrub pad and fresh cleaning solution. Rinse scrub pad frequently. Drag a clean sponge diagonally over the scrubbed surfaces to remove froth. Use each side of sponge only once before rinsing and change cleaning solution at least every 50 ft<sup>2</sup> (4.7 m<sup>2</sup>). Allow cleaned areas to dry and inspect tile/stone surface. For persistent grout film/haze (within 24 hours), repeat scrubbing procedure with undiluted white vinegar and clean pad. Rinse with clean water and allow surface to dry. Inspect grout joint for pinholes/voids and repair them with freshly mixed LATICRETE® SpectraLOCK® PRO Grout†.

**CAUTIONS:** Do not use undiluted white vinegar on polished marble or limestone unless a test spot in an inconspicuous area indicates no change in finish appearance; do not use acid cleaners on epoxy grout less than 7 days old.

**Use the following LATICRETE® System Materials**  
LATICRETE SpectraLOCK PRO Grout

### References

LATICRETE Data Sheets: 685.0, 685.5

LATICRETE MSDS: Pro Part A, Pro Part B, Part C Powder, Cleaning Additive

GREENGUARD Certificate: PRO

LATICRETE Technical Data Sheets: 111, 198, 212, 400

2. Polymer Fortified Cement Grout (ANSI A118.7): Allow ceramic tile, mosaics, pavers, brick or stone installation to cure a minimum of 24 hours at 70° F (21°C). Verify grout joints are free of dirt, debris or tile spacers. Sponge or wipe dust/dirt off veneer face and remove any water standing in joints. Apply grout release to face of absorptive, abrasive, non-slip or rough textured ceramic tile, pavers, bricks, or trim units that are not hot paraffin coated to facilitate cleaning. Surface temperature must be between 40–90°F (4–32°C). Pour approximately 64 oz (1.9 l) of clean, potable water into a clean mixing container. Add a 25 lb (11.3 kg) bag of LATICRETE PermaColor™ Grout<sup>^</sup> to the container while mixing. Mix by hand or with a slow speed mixer to a smooth, stiff consistency. Install latex fortified cement grout in compliance with current revisions of ANSI A108.1A (7.0 Grouting of tile), ANSI A108.02 (4.5 Cleaning tile) and ANSI A108.10. Dampen dry surfaces with clean water. Spread using a sharp edged, hard rubber float and work grout into joints. Using diagonal (at 45° angle to direction of grout line) strokes, pack joints full and free of voids/pits. Hold float face at a 90° angle to grouted surface and use float edge to “squeegee”

off excess grout, stroking diagonally to reduce pulling grout out of filled joints. Initial cleaning can begin as soon as grout has become firm, typically 15–20 minutes after grouting at 70°F (21°C). Higher temperatures may require faster time to initial cleaning; wider joints or lower temperatures may require a longer time to initial cleaning. Begin initial cleaning by lightly dampening the entire grouted area with a damp sponge. Then wash clean the entire area with a damp (not wet) sponge. Drag a clean towel, dampened with water, or wipe a clean, dampened sponge, diagonally over the veneer face to remove any grout haze left after “squeegeeing.” Rinse towel/sponge frequently and change rinse water at least every 200 ft<sup>2</sup> (19 m<sup>2</sup>). Repeat this cleaning sequence again if grout haze is still present. Allow grout joints to become firm. Buff surface of grout with clean coarse cloth. Inspect joint for pinholes/voids and repair them with freshly mixed grout. Within 24 hours, check for remaining haze and remove it with warm soapy water and a nylon scrubbing pad, using a circular motion, to lightly scrub surfaces and dissolve haze/film. Do not use acid cleaners on latex portland cement grout less than 10 days old.

**NOTE TO SPECIFIER:** Select one of following and specify color for each type/color of ceramic tile, mosaic, paver, trim unit:

1. Latex-portland cement sanded floor grout for joint widths  $\geq 1/16"$  (1.5 mm) and  $\leq 1/2"$  (12 mm);
2. Latex-portland cement unsanded grout for soft glazed tiles and soft/polished stone with joints widths  $\leq 1/8"$  (3 mm).

**Use the following LATICRETE System Materials**  
LATICRETE PermaColor Grout

### References

LATICRETE Data Sheets: 250.0

LATICRETE MSDS: 2500

GREENGUARD Certificates: 2500

LATICRETE Technical Data Sheets: 201, 400

G. Expansion and Control Joints: Provide control or expansion joints as located in contract drawings and in full conformity, especially in width and depth, with architectural details.

1. Substrate joints must carry through, full width, to surface of tile, brick or stone.
2. Install expansion joints in tile, brick or stone work over construction/cold joints or control joints in substrates.
3. Install expansion joints where tile, brick or stone abut restraining surfaces (such as perimeter walls, curbs, columns), changes in plane and corners.
4. Joint width and spacing depends on application – follow TCNA “Handbook for Ceramic Tile Installation” Detail “EJ–171 Expansion Joints” or consult sealant manufacturer for recommendation based on project parameters.
5. Joint width:  $\geq 1/8"$  (3 mm) and  $\leq 1"$  (25 mm).
6. Joint width: depth ~2:1 but joint depth must be  $\geq 1/8"$  (3 mm) and  $\leq 1/2"$  (12 mm).
7. Layout (field defined by joints): 1:1 length: width is optimum but must be  $\leq 2:1$ . Remove all contaminants and foreign material from joint spaces/surfaces, such as dirt, dust, oil, water, frost, setting/grouting materials, sealers and old sealant/backer. Use LATICRETE Latasil™ 9118 Primer for underwater and permanent wet area applications, or for porous stone (e.g. limestone, sandstone etc...) installations. Install appropriate backing material (e.g. closed cell backer rod) based on expansion joint design and as specified in § 07920. Apply masking

tape to face of tile, brick or stone veneer. Use caulking gun, or other applicator, to completely fill joints with sealant. Within 5–10 minutes of filling joint, ‘tool’ sealant surface to a smooth finish. Remove masking tape immediately after tooling joint. Wipe smears or excess sealant off the face of non-glazed tile, brick, stone or other absorptive surfaces immediately.

### Use the following LATICRETE® System Materials

LATICRETE® Latasil™

LATICRETE Latasil 9118 Primer

### References

LATICRETE Detail Drawings: WP300, WP301, WP302, WP303, EJ-01, EJ-02, EJ-03, EJ-04, EJ-05, EJ-06, EJ-07, EJ-08, EJ-09, EJ-10, EJ-11, EJ-12, EJ-13, EJ-14, EJ-15, P605 (Sealant treatments only)

LATICRETE Data Sheets: 6200.1, 6528.1

LATICRETE MSDS: Latasil, Primer

LATICRETE Technical Data Sheets: 211, 252

H. Adjusting: Correction of defective work for a period of one (1) year following substantial completion, return to job and correct all defective work. Defective work includes, without limitation, tiles broken in normal abuse due to deficiencies in setting bed, loose tiles or grout, and all other defects which may develop as a result of poor workmanship.

### 3.5 Cleaning

Clean excess mortar/epoxy from veneer surfaces with water before they harden and as work progresses. Do not contaminate open grout/caulk joints while cleaning. Sponge and wash veneers diagonally across joints. Do not use acids for cleaning. Polish with clean dry cloth. Remove surplus materials and leave premises broom clean.

### 3.6 Protection

- A. Protect finished installation under provisions of §01500 and §01535. Close areas to other trades and traffic until tile being installed has set firmly. Keep traffic off horizontal portland cement thick bed mortar installations for at least 72 hours at 70°F (21°C)
- B. Keep floors installed with epoxy adhesive closed to foot traffic for 24 hours at 70°F (21°C), and to heavy traffic for 48 hours at 70°F (21°C) unless instructed differently by manufacturer. Use kneeling boards, or equivalent, to walk/work on newly tiled floors. Cure tile work in swimming pools, fountains and other continuous immersion applications for 10 days at 70°F (21°C) for epoxy based grout and 14 days at 70°F (21°C) for latex portland cement based grout before flood testing or filling installation with water. Extend period of protection of tile work at lower temperatures, below 60°F (15°C), and at high relative humidity (>70% RH) due to retarded set times of mortar/adhesives. Replace or restore work of other trades damaged or soiled by work under this section.

### **PART 4 – HEALTH AND SAFETY**

The use of personal protection such as rubber gloves, suitable dust masks, safety glasses and industrial clothing is highly recommended. Discarded packaging, product wash and waste water should be disposed of as per local, state or federal regulations.

“As a professional courtesy, LATICRETE offers technical services free of charge. The user maintains all responsibility for verifying the applicability and suitability of the technical service or information provided.”

The right to copy, distribute and utilize for commercial purposes is granted exclusively to architects, engineers, and specification writers. Execution Statements are subject to change without notice. For latest revision, check our website at [www.laticrete.com](http://www.laticrete.com)

ES–SR614 R

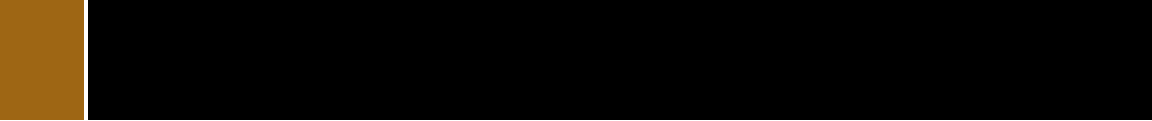

## Section 4: Steam Room Detail Drawings



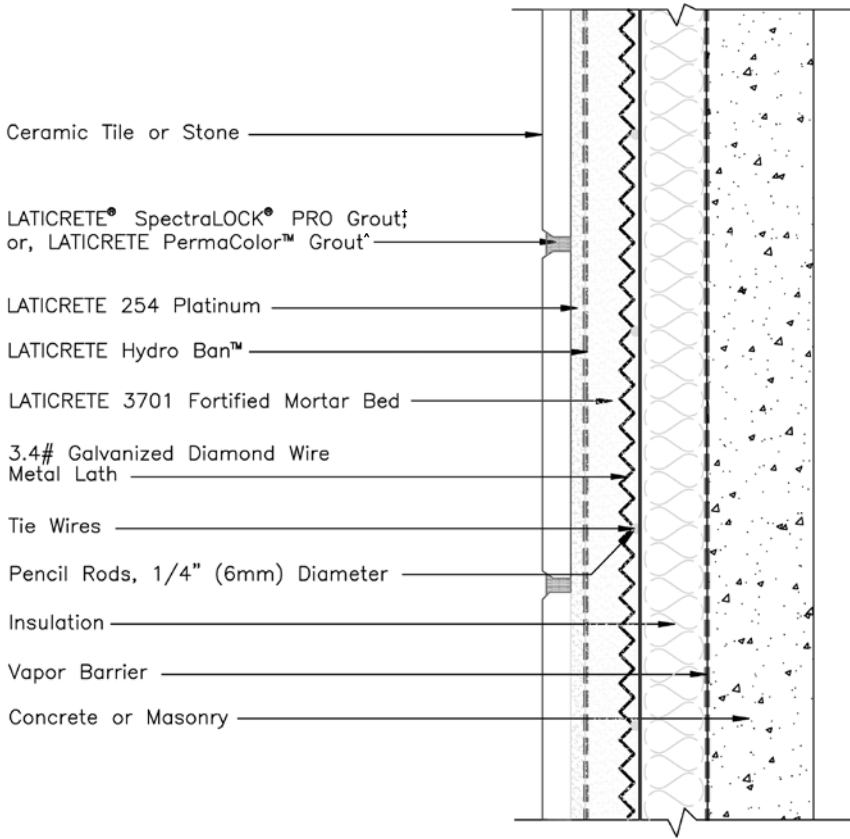

Revision Date: 09/09  
 Scale: NTS

**NOTE:** For complete application information and limitations consult related Product Data Sheets and Execution Statements related to this detail and applicable industry standards.

As a professional courtesy, LATICRETE offers technical services free of charge. The user maintains all responsibility for verifying the applicability and suitability of the technical service or information provided.

<sup>†</sup> United States Patent No.: 6881768 (and other Patents).  
<sup>^</sup> United States Patent No.: 6784229 B2 (and other Patents).

©2009 LATICRETE INTERNATIONAL, INC. ALL RIGHTS RESERVED. The right to utilize LATICRETE details for commercial purposes is granted exclusively to contractors, architects, quantity surveyors, engineers, and specifications writers. LATICRETE<sup>®</sup>, LATAPOXY<sup>®</sup>, SPECTRALOCK<sup>®</sup> are registered trademarks of LATICRETE International, Inc. U.S. and Foreign Patent and Trademark Offices, Marca Registrada. All other trademarks are property of their respective companies.



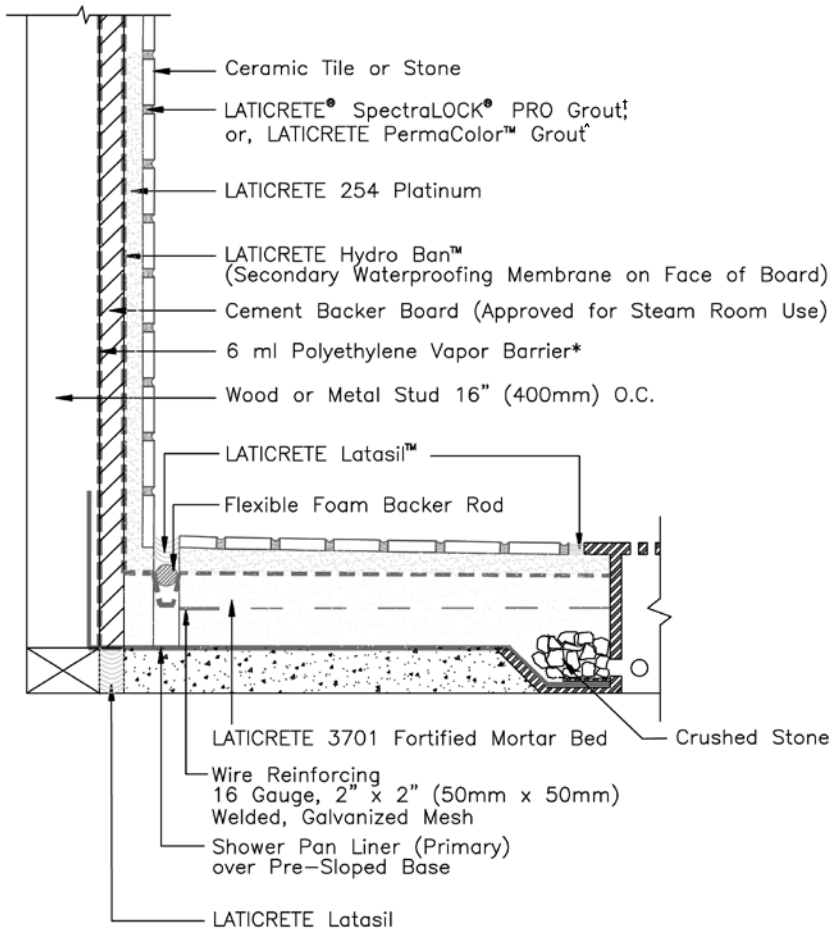

\* Vapor Barrier laps into Shower Pan Membrane (as shown)

Revision Date: 09/09  
Scale: NTS

**NOTE:** For complete application information and limitations consult related Product Data Sheets and Execution Statements related to this detail and applicable industry standards.

† United States Patent No.: 6881768 (and other Patents).

‡ United States Patent No.: 6784229 B2 (and other Patents).

©2009 LATICRETE INTERNATIONAL, INC. ALL RIGHTS RESERVED. The right to utilize LATICRETE details for commercial purposes is granted exclusively to contractors, architects, quantity surveyors, engineers, and specifications writers. LATICRETE®, LATAPOXY®, SPECTRALOCK® are registered trademarks of LATICRETE International, Inc. U.S. and Foreign Patent and Trademark Offices, Marca Registrada. All other trademarks are property of their respective companies.

As a professional courtesy, LATICRETE offers technical services free of charge. The user maintains all responsibility for verifying the applicability and suitability of the technical service or information provided.

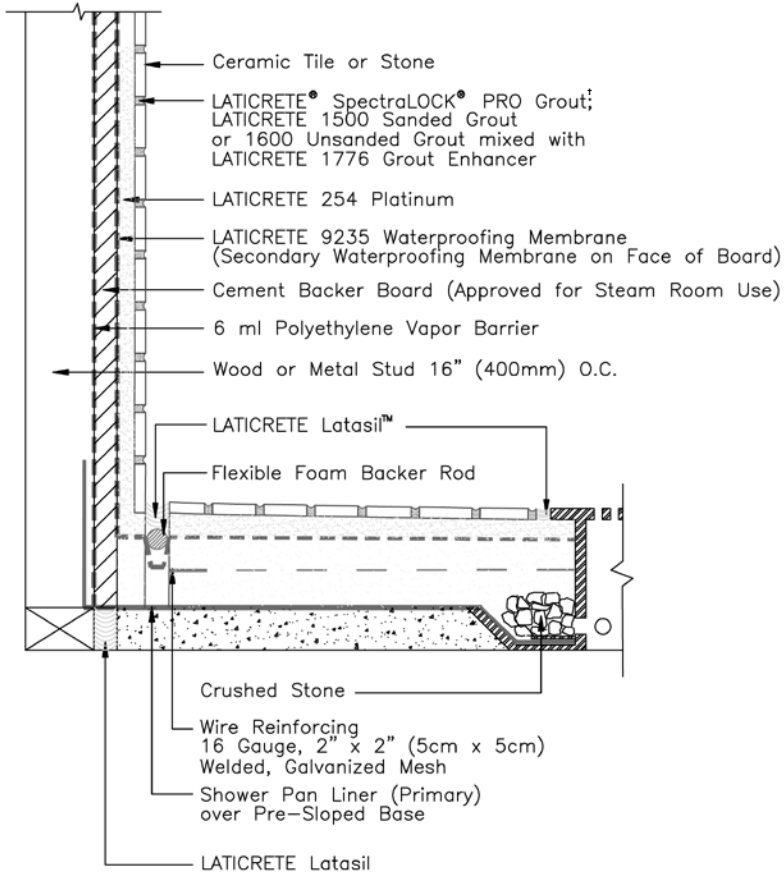

\* Vapor Barrier laps over Shower Pan Membrane.

Revision Date: 11/07  
Scale: NTS

**NOTE:** For complete application information and limitations consult related Product Data Sheets and Execution Statements related to this detail and applicable industry standards.

As a professional courtesy, LATICRETE offers technical services free of charge. The user maintains all responsibility for verifying the applicability and suitability of the technical service or information provided.

\* United States Patent No.: 6881768 (and other Patents).  
^ United States Patent No.: 6784229 B2 (and other Patents).

©2009 LATICRETE INTERNATIONAL, INC. ALL RIGHTS RESERVED. The right to utilize LATICRETE details for commercial purposes is granted exclusively to contractors, architects, quantity surveyors, engineers, and specifications writers. LATICRETE®, LATAPOXY®, SPECTRALOCK® are registered trademarks of LATICRETE International, Inc. U.S. and Foreign Patent and Trademark Offices, Marca Registrada. All other trademarks are property of their respective companies.

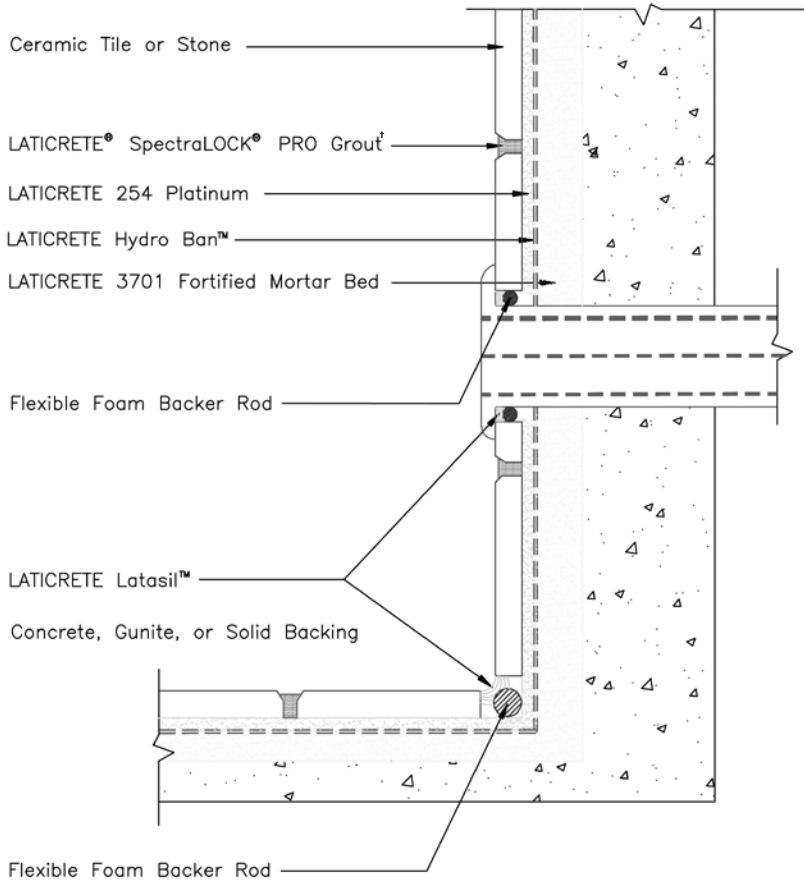

Revision Date: 11/07  
 Scale: NTS

**NOTE:** For complete application information and limitations consult related Product Data Sheets and Execution Statements related to this detail and applicable industry standards.

As a professional courtesy, LATICRETE offers technical services free of charge. The user maintains all responsibility for verifying the applicability and suitability of the technical service or information provided.

<sup>†</sup> United States Patent No.: 6881768 (and other Patents).  
<sup>^</sup> United States Patent No.: 6784229 B2 (and other Patents).

©2009 LATICRETE INTERNATIONAL, INC. ALL RIGHTS RESERVED. The right to utilize LATICRETE details for commercial purposes is granted exclusively to contractors, architects, quantity surveyors, engineers, and specifications writers. LATICRETE®, LATAPOXY®, SPECTRALOCK® are registered trademarks of LATICRETE International, Inc. U.S. and Foreign Patent and Trademark Offices, Marca Registrada. All other trademarks are property of their respective companies.

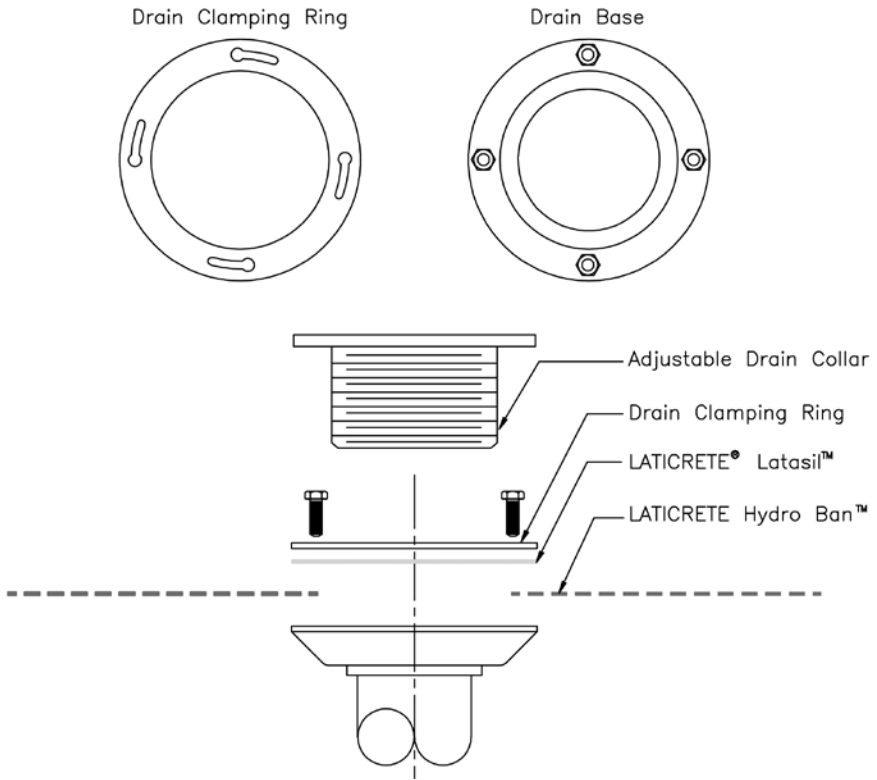

Revision Date: 11/07  
Scale: NTS

**NOTE:** For complete application information and limitations consult related Product Data Sheets and Execution Statements related to this detail and applicable industry standards.

As a professional courtesy, LATICRETE offers technical services free of charge. The user maintains all responsibility for verifying the applicability and suitability of the technical service or information provided.

©2009 LATICRETE INTERNATIONAL, INC. ALL RIGHTS RESERVED. The right to utilize LATICRETE details for commercial purposes is granted exclusively to contractors, architects, quantity surveyors, engineers, and specifications writers. LATICRETE®, LATAPOXY®, SPECTRALOCK® are registered trademarks of LATICRETE International, Inc. U.S. and Foreign Patent and Trademark Offices, Marca Registrada. All other trademarks are property of their respective companies.

## Section 5: Maintenance and Protection



### 5.1 Quality Assurance

The success of a steam room/steam shower project depends entirely on a good quality assurance program implemented at all levels of the project. Unfortunately, comprehensive quality assurance programs remain the most often overlooked and ignored process in the design and construction of steam rooms and steam showers. There is an important distinction between the terms “quality assurance” and “quality control”. The distinction is that quality assurance is preventative in nature and encompasses all the procedures necessary to insure quality, from design through implementation. Quality control is corrective in nature, typically implemented during or after a procedure, and is only one component of a more comprehensive and planned quality assurance program. A quality assurance program should include quality checks during the design, specification and bidding phases as well as during and after construction. One factor of tile installations in steam room/steam shower applications is the quality of the installation is only as good as each component, and it’s installation, of the system. So choosing the proper products and installing them correctly is critical to the long-term performance of the steam room.

A comprehensive quality program for the design and construction of steam rooms and steam showers should involve the following:

#### Owner

- Define Scope of Work
- Organizational Requirements
- Quality Objectives

#### Design Professional

- Wall System, Shower Pan/Floor System and Ceiling System Product Component Design, Specification, Installation, and Inspection Procedure Training
- Pre-Installation Conference Materials and Methods
- Identification of Construction Progress and Post Installation Inspection, Testing and Evaluation Requirements; Identify Resolution Methods for Non-Compliant Conditions
- Develop and Specify Post Installation Preventative Maintenance Programs

#### Construction Professional

- Substrate Preparation
- Control of Materials (Evaluation of Contract Document Performance Requirements, Material Suppliers, Delivery, Handling, Records
- Product Use Monitoring and Documentation (Pot Life, Curing, Protection and Batch Mixing)
- Setting or Fixing of Tile or Stone – Adhesion Monitoring (Spreading, Thickness, Open Time, Tackiness, Beat-In, Coverage)
- Clean-Up and Protection

### 5.2 Preventative and Corrective Maintenance

A systematic maintenance plan is a critical required final step in steam rooms which is often overlooked. A steam room is exposed to harsh, deteriorating conditions and without regular maintenance, the normal deterioration process will be accelerated. The result is a loss of performance and shortening of expected service life.

Maintenance of steam rooms is categorized according to how and when maintenance actions are taken. Preventative maintenance is planned and proactive action, which maintains specified performance, prevents potential defects or failures. Preventative maintenance includes both anticipated routine actions and repairs, such application of protective sealers or deteriorated sealant replacement, as well as unexpected repairs such as replacement of cracked tile or stone, or correcting water leaks that may manifest into structural problems later.

The benefits of preventative maintenance are well documented; prevention has been proven to increase expected service life, and cost a fraction of more extensive remedial action typically required once a problem occurs.

Corrective maintenance is remedial action which repairs a defect after occurrence. Corrective maintenance is necessary to prevent further deterioration or total failure of a steam room system. Corrective maintenance typically involves evaluation with either a non-destructive or destructive test procedure.

The use of LATICRETE® SpectraLOCK®† PRO Grout aids in the maintenance of the installation. This grout reduces the amount of time needed to clean, seal and provide general upkeep typically required with traditional cement based products.

### 5.3 Protection and Sealing

#### Water Repellent Sealers and Coatings

The purpose and performance of these materials is widely misunderstood by design and construction professionals. Generally, clear water repellent coatings can aid to retard surface water absorption of porous materials, and reduce adhesion of atmospheric pollution and other stains. However, these materials often give a false sense of security due to the lack of understanding of their suitability, compatibility, and performance. Water repellents can reduce water leakage and deterioration in normally porous tile, stone or grout materials, but they are not a cure to abnormal leakage caused by fundamental defects in detailing and construction.

There are several general principles for use and application of sealers. Water repellent sealers are not waterproof, and generally can not bridge gaps or hairline cracks in grout joints or the cladding material, so these materials are useless when used over cracks or very porous materials. Sealers suitable for steam rooms must be vapor permeable, and allow the wall materials to “breathe” vapor but stop water. Sealers can also create functional or aesthetic defects that are intended to be prevented or corrected by their application. For example, sealers may be harmful if water infiltrates behind the wall assembly, either through hairline cracks/gaps, or through poorly designed or constructed wall interfaces. Sealers can trap water within a wall, and cause efflorescence, spalling/exfoliation of the cladding material, or structural damage.

As sealers age and weather, several other problems can occur. Effectiveness is typically reduced over time, so periodic re-application (depending on the manufacturers formulation and recommendations) is necessary; effective service life ranges from 2–5 years. Sealers

may also allow variable wetting of the grout, tile or stone from poor application or from weathering; this can produce a blotchy appearance. In some cases the sealer can be re-applied; in others it may be necessary to allow it to completely weather off, or be removed chemically to restore a uniform appearance. Please check with sealer manufacturer for complete information on their products.

Compatibility of sealers is also important, not only with the materials to be sealed, but also adjacent and underlying components of the steam room system. The appearance of certain tile, stone or grout materials can be affected by sealers. Poor application or poor quality products can darken or change appearance. Silicone based sealer formulations cause discoloration on high lime surfaces such as limestone or marble. Application (or overspray) of sealers to non-porous tile such as porcelain will result in visible residue or a dripping, wet appearance from sealers that do not absorb (e.g. acrylics and urethanes). Sealant joints, waterproofing membranes, and metal are some of the system components which could be affected by solvents in some formulations.

Prior to application of water repellents, all joint sealant work should cure a minimum of 72 hours; the solvents in these materials can affect the cure of sealants. Protection should also be provided for other solvent-sensitive material, such as waterproofing membranes, rubber, glass, and metal frames, by saturating with dish washing soap and water prior to application. Most water based formulations are non-reactive with solvent sensitive materials.

### **As an Alternative to Using Sealers**

Use LATICRETE® SpectraLOCK®† PRO Grout in conjunction with a porcelain bodied tile. LATICRETE SpectraLOCK PRO Grout never needs sealing. The grout becomes just as dense and durable as the porcelain tile.



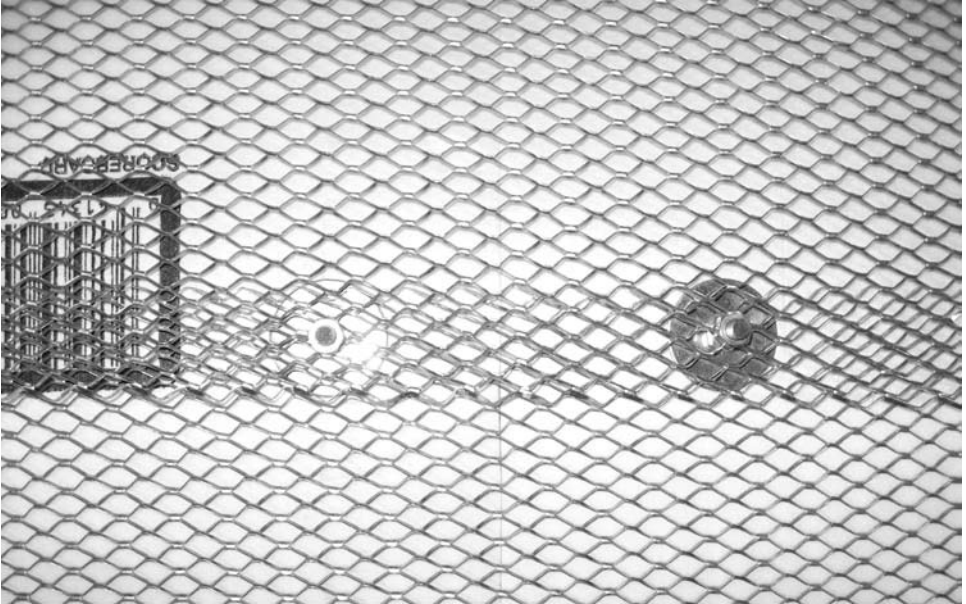

3.2# expandable diamond metal lath fastened to rigid foam insulation board which has been installed over a vapor barrier.



Bench/wall transition and proper placement of 3.2# expandable diamond metal lath.

## Section 5: Case Study – Full Mortar Bed Steam Room

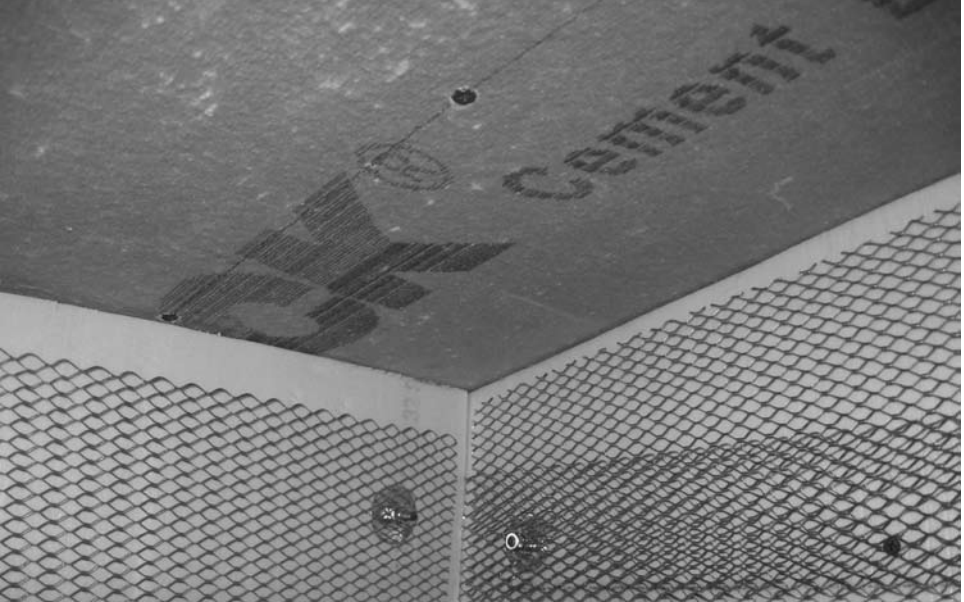

Transition of walls to ceiling prior to installation of LATICRETE® 226 Thick Bed Mortar and LATICRETE 3701 Mortar Admix scratch coat.

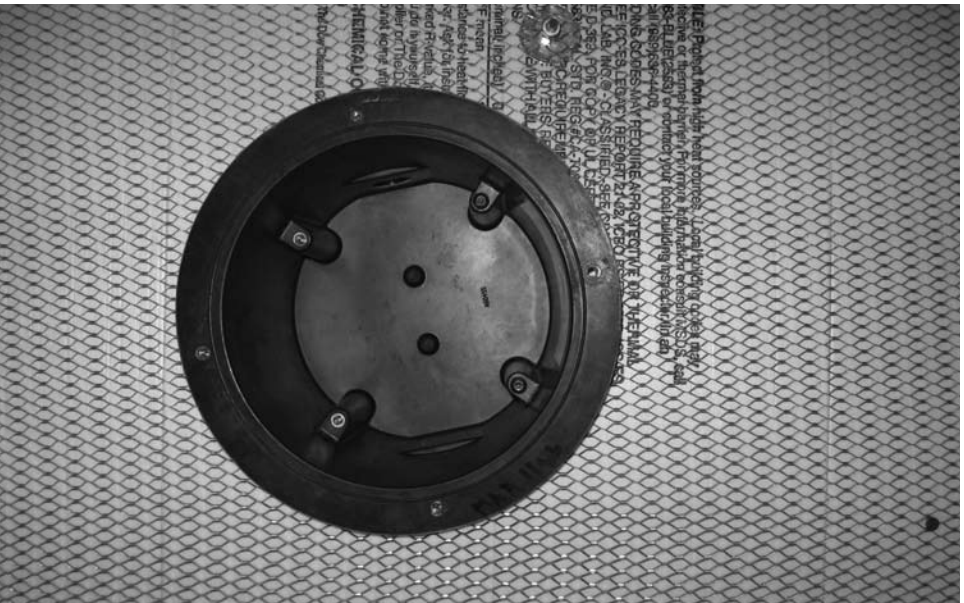

Proper tie-in of 3.2# expandable diamond metal lath to steam room light fixture.



Ceiling (with sprinkler head) showing Tile Council of North America (TCNA) recommended pitch of 2" per foot (50 mm per 300 mm).

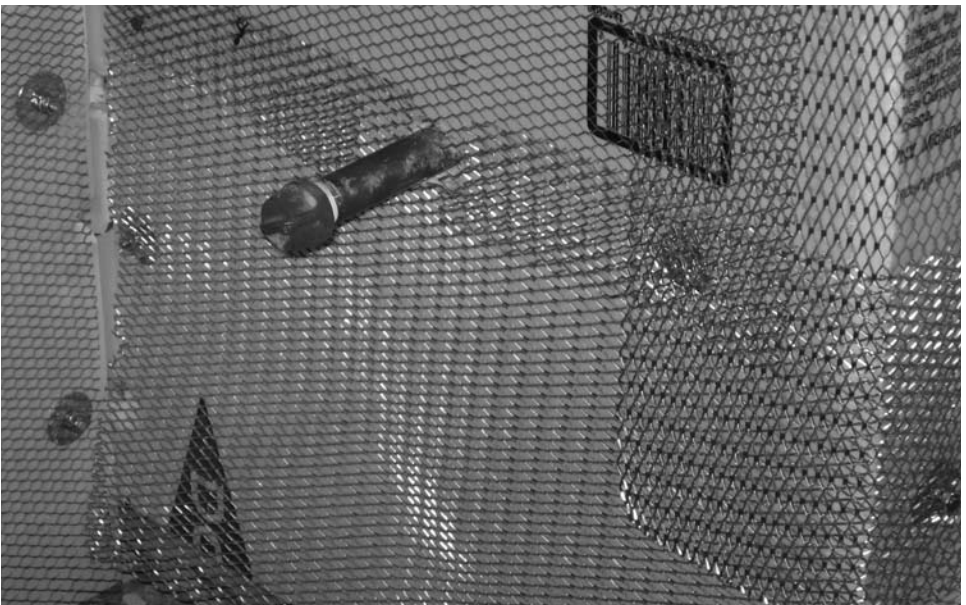

Pipe penetration for steam generation unit and proper tie-in of 3.2# expandable diamond metal lath.

Section 5: Case Study – Full Mortar Bed Steam Room



Installation of 3.2# expandable diamond metal lath to stainless steel door frame and flashing.



Wall partially finished with scratch coat of LATICRETE® 226 Thick Bed Mortar and LATICRETE 3701 Mortar Admix.



Finishing the application of the LATICRETE 226 Thick Bed Mortar and LATICRETE 3701 Mortar Admix scratch coat.

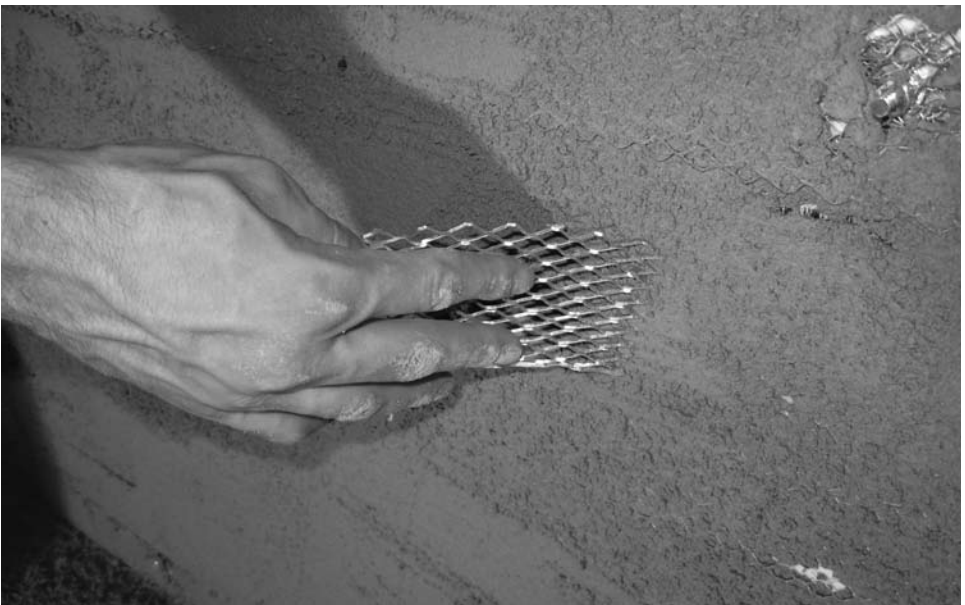

Scratching the LATICRETE 226 Thick Bed Mortar and LATICRETE 3701 Mortar Admix with a piece of metal lath.

## Section 5: Case Study – Full Mortar Bed Steam Room



A finished, scratch coat wall which is now ready for “the float coat.”



The steam room seats after the installation of the LATICRETE® 3701 Mortar Admix and LATICRETE 226 Thick Bed Mortar.



Pre-treatment of ceiling joint with 6" (150 mm) wide, treatment of LATICRETE 9235 Waterproofing Membrane.



Lighting fixture waterproofing membrane pre-treatment. The vapor retarder, insulation board, mud bed, and LATICRETE 9235 Waterproofing Membrane are all clearly visible.



Waterproofing treatment of corner and floor with LATICRETE® 9235 Waterproofing Membrane.

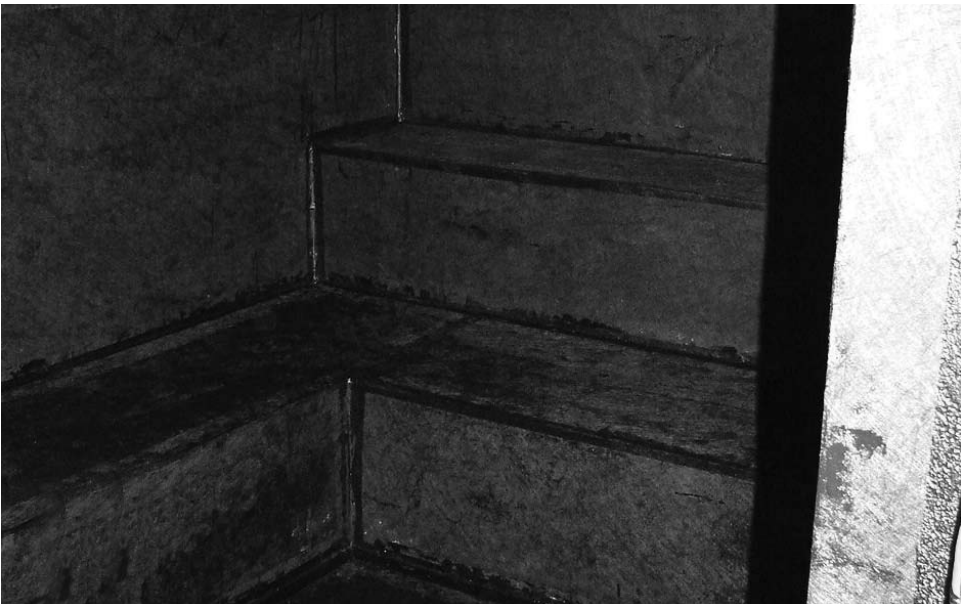

Completed installation of LATICRETE 9235 Waterproofing Membrane over all seat, wall, ceiling and floor surfaces.



## Section 5: Case Study – Full Mortar Bed Steam Room



Installation of tile onto LATICRETE 9235 Waterproofing Membrane using LATICRETE 254 Platinum.



Continuing installation of tile onto all surfaces using LATICRETE 254 Platinum.

## Section 5: Case Study – Full Mortar Bed Steam Room



Finished installation of 2" x 2" (5 cm x 5 cm) vitreous tile using LATICRETE® 254 Platinum. Notice the cut-out for the emergency call switch.



Installation of LATICRETE 1500 Sanded Grout mixed with LATICRETE 1776 Grout Enhancer on ceiling, walls and seat.

## Section 5: Case Study – Full Mortar Bed Steam Room

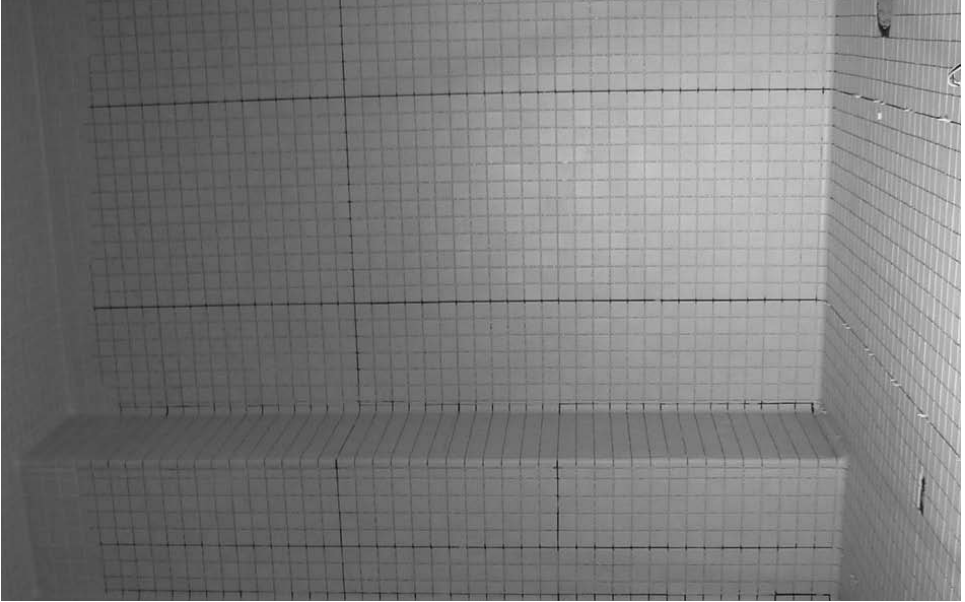

Finished wall, ceiling and seat installation.



Finished floor installation of tile. Floor and seats are sloped  $1/4$ " per foot (6 mm per 300 mm) to the drain.

## Section 5: Case Study – Full Mortar Bed Steam Room



Finished wall showing door, light and emergency call switch installations.

Tile provided and installation done by: Coastal Tile and Marble, Branford, CT.

## Section 6: Appendix

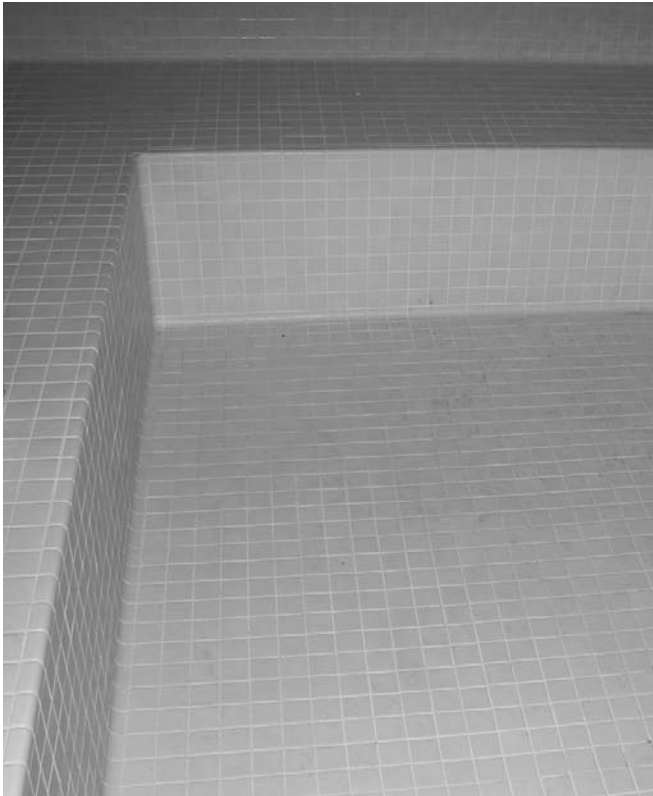

## Section 6: Steam Room Frequently Asked Questions

### **Q: Do I need a shower pan for my steam room/steam shower?**

Yes. A shower pan is an extremely important component of any steam room, steam shower or regular shower and may be required per building code. A vinyl liner (or other vapor impermeable material which can be used as a shower pan membrane) is perfectly suited for this type of application and must be properly installed to protect against damage caused by water.

### **Q: Does the floor of the steam room require a pitch to drain?**

Yes. In fact, the pitch must exist in the sub-floor so water that accumulates in the shower pan flows towards the drain weep holes. If the sub-floor is properly pitched then the depth of the mortar bed can remain a consistent depth. The pitch to drain for steam room/steam shower floor installations is recommended at 1/4" per foot (6 mm per 300 mm).

### **Q: Should I conduct a flood test in my steam room prior to setting tile?**

Yes. It is important to verify that the shower pan does not leak prior to setting tile. For more information on flood testing requirements and procedures, please refer to TDS 169 "Flood Testing Procedures" at [www.laticrete.com](http://www.laticrete.com).

### **Q: Why do I need a vapor barrier in my steam room/steam shower if I have a waterproofing membrane?**

LATICRETE® Hydro Ban™ and LATICRETE 9235 Waterproofing Membrane, like most waterproofing membranes, prevents water from penetrating past the membrane. However, like most waterproofing membranes, LATICRETE Hydro Ban and LATICRETE 9235 Waterproofing Membrane are vapor permeable. Moisture vapor will be able to permeate through the membrane, water itself will not. In a steam room environment the moisture that enters the room is in vapor form and is also under some pressure. The vapor barrier is designed and placed to keep the moisture vapor from entering into areas where the vapor will condense and possibly cause structural and mold/health problems.

### **Q: Should the vapor barrier drape into the shower pan liner?**

Yes. As water vapor permeates through the tile installation and the waterproofing membrane, the moisture will hit the impermeable vapor barrier. The moisture will eventually condense into water form and, by gravity, work its way down into the shower pan. A moisture barrier that has been improperly placed means that the water will end up on the outside of the shower pan. This can lead to structural damage and mold/health problems.

### **Q: Where should a vapor barrier be placed in a steam room installation?**

According to ES-SR613 the vapor barrier would be placed directly onto the concrete or masonry. In ES-SR614 the vapor barrier is placed directly onto the face of the studs (steel or wood), directly underneath (in contact with) the cement backer board and fastened with corrosion resistant fasteners. A spot of LATICRETE Latacil™ should then be placed onto each fastener to help prevent moisture penetration through the fastener hole. Please refer to the appropriate execution statement located in this design manual or at [www.laticrete.com/ag](http://www.laticrete.com/ag) for more information.

### **Q: If there is no "water" in a steam room then why do I need a waterproofing membrane?**

In actuality, there is water in a steam room; a significant amount of water. Water enters the room as a vapor, meaning it must be heated to a temperature greater than 212°F (100°C). As the steam enters the room it will condense when it hits dew point and the resulting water must have an escape route. Directly or indirectly the condensed water in the steam room will end up going through the drain.

### **Q: Do I require a waterproofing membrane on the walls and ceiling?**

Yes. The waterproofing membrane is required throughout the steam room/steam shower installation to help limit the amount of moisture vapor that reaches the vapor barrier. The low perm rating of LATICRETE Hydro Ban and LATICRETE 9235 Waterproofing Membrane means that a very low amount of water will come in contact with the vapor barrier.

**Q: Does a steam room/steam shower ceiling require a pitch?**

Yes. The ceiling requires a pitch to prevent water droplets from falling onto steam room occupants. It also prevents water from staying on the ceiling surface for extended periods of time. The recommended pitch for a ceiling in a steam room is 2" per foot (50 mm per 300 mm) minimum.

**Q: Do I need a vapor barrier on the ceiling?**

Yes. Water vapor in a steam room will definitely come in contact with the ceiling. The vapor barrier must be placed within the entire confines of the steam room structure so that no moisture vapor can transpire into the surrounding building structure or spaces.

**Q: Is insulation required in my steam room/steam shower?**

This is a question that should be answered by the project design professional. Applications and project conditions may vary and will have a direct impact on the use of insulation. The use of a suitable insulation should dramatically improve the performance of the steam room/steam shower and help to conserve energy.

**Q: How do I waterproof the penetrations (e.g. steam jets, pipes, drains, lights, etc...) in my steam room/steam shower?**

For steam jets and pipes you can refer to Detail ES-P605 (located in Section 4.4) for direction. For drains you can refer to detail WP302 (located in Section 4.5).

**Q: What LATICRETE Thin-Set should I use for my steam room installation?**

LATICRETE 254 Platinum, a premium multipurpose thin-set mortar is ideal for installing most types of tile or stone in a steam room/steam shower environment. For installation of resin backed stone, moisture sensitive tile or stone, mesh backed mosaics, or dot mounted mosaics it is recommended that LATAPOXY® 300 Adhesive be used. For more information please contact LATICRETE Technical Services at support@laticrete.com

**Q: What LATICRETE grout should I use for my steam room/steam shower?**

The ideal grout would be LATICRETE SpectraLOCK®+ PRO Grout. LATICRETE SpectraLOCK PRO Grout provides an extremely low absorption rate, antimicrobial protection, a significant reduction in efflorescence problems, and ease of installation making it the ideal choice for a steam room/steam shower environment. LATICRETE PermaColor™ Grout+ is also suitable for steam room use.

**Q: Does LATICRETE Latasil™ require the LATICRETE 9118 Primer prior to application?**

Yes. Due to the amount of moisture in a steam room/steam shower, it is a good idea to treat this type of installation the same way that you would treat a swimming pool LATICRETE Latasil application.

**Q: If I use a cement based grout will efflorescence be a concern?**

Yes. Efflorescence can be a concern when a portland cement based grout is used in a steam room installation. The high amount of moisture and the fact that the moisture will work its way back out through the grout can, very possibly lead to efflorescence problems. An easy way to reduce efflorescence problems is to use LATICRETE SpectraLOCK PRO Grout.

**Q: What regular maintenance is needed for a steam room?**

Outside of maintaining the steam generation unit (contact steam generation unit manufacturer for more information) a steam room requires some regular maintenance. Establish a suitable and consistent cleaning regimen for long term, safe and healthy steam room enjoyment.

## Section 6: Resource Guide

### **Ceramic Tile Materials and Methods**

Tile Council of North America, Inc. (TCNA)  
100 Clemson Research Blvd.  
Anderson, SC 29625  
864.646.8453  
www.tileusa.com

Terrazzo, Tile & Marble Association of Canada (TTMAC)  
30 Capston Gate, Unit 5  
Concord, Ontario, Canada L4K 3E8  
905.660.9640  
www.ttmac.com

Ceramic Tile Institute of America, Inc.  
12061 West Jefferson  
Culver City, CA 90230-6219  
310.574.7800  
www.ctioa.org

Tile Contractors Association of America (TCAA)  
4 East 113th Terrace  
Kansas City, MO 64114  
800.655.8453  
www.tcaainc.org

National Tile Contractors Association (NTCA)  
P.O. Box 13629  
626 Lakeland East Dr.  
Jackson, MS 39236  
601.939.2071  
www.tile-assn.com

International Masonry Institute (IMI)  
The James Brice House  
42 East St.  
Annapolis, MD 21401  
410.280.1305  
www.imiweb.org

### **Natural Stone Methods and Materials**

Marble Institute of America (MIA)  
28901 Clemens Rd.  
Westlake, OH 44145  
440.250.9222  
www.marble-institute.com

Masonry Institute of America  
22815 Frampton Ave.  
Torrance, CA 90501-5034  
800.221.4000  
www.masonryinstitute.org

### **Thin Brick Masonry Materials and Methods**

Brick Institute of America (BIA)  
11490 Commerce Park Dr.  
Suite 300  
Reston, VA 22091  
703.620.0010  
www.bia.org

International Masonry Institute (IMI)  
The James Brice House  
42 East St.  
Annapolis, MD 21401  
410.280.1305  
www.imiweb.org

Masonry Institute of America  
22815 Frampton Ave.  
Torrance, CA 90501-5034  
800.221.4000  
www.masonryinstitute.org

National Concrete Masonry Association (NCMA)  
13750 Sunrise Valley Dr.  
Herndon, VA 20171-4662  
703.713.1900  
www.ncma.org

### **Concrete, Pre-Cast Concrete**

Portland Cement Association  
5420 Old Orchard Rd.  
Skokie, IL 60077  
847.966.6200  
www.cement.org

Precast/Prestressed Concrete Institute (PCI)  
209 West Jackson Blvd.  
Chicago, IL 60606  
312.786.0300  
www.pci.org



Wire Reinforcement Institute (WRI)  
942 Main St.  
Hartford, CT 06103  
800.542.4974  
www.wirereinforcement.org

American Concrete Institute (ACI)  
P.O. Box 9094  
Farmington Hills, MI 48333-9094  
248.848.3700  
www.concrete.org

### **Test Standards and Building Codes**

American Society for Testing & Materials  
International (ASTM)  
100 Barr Harbor Dr.  
P.O. Box C700  
West Conshohocken, PA 19428-2959  
610.832.9585  
www.astm.org

Materials and Methods Standards Association  
(MMSA)  
P.O. Box 350  
Grand Haven, MI 49417-0350  
616.842.7844  
www.mmsa.ws

International Code Council (ICC)  
4051 West Flossmoor Rd.  
Country Club Hills, IL 60478-5795  
888.422.7233  
www.iccsafe.org

United States Green Building Council (USGBC)  
1015 18th St., NW  
Suite 508  
Washington DC 20036  
202.828.7422  
www.usgbc.org

American National Standards Institute (ANSI)  
1819 L St., NW 6th Floor  
Washington, DC 20036  
202.293.8020  
www.ansi.org

International Organization for Standardization  
(ISO)  
1, rue de Varembeé, Casa postale 56  
CH-1211 Geneva 20, Switzerland  
41 22 749 01 11  
www.iso.org

National Institute of Building Sciences (NIBS)  
1090 Vermont Ave., NW  
Suite 700  
Washington, DC 20005-4905  
202.289.7800  
www.nibs.org

### **Sealants, Waterproofing and Adhesives**

Sealant, Waterproofing & Restoration Institute  
(SWRI)  
14 West 3rd St.  
Suite 200  
Kansas City, MO 64105  
816.472.7974  
www.swrionline.com

Adhesive & Sealant Council, Inc.  
7979 Old Georgetown Rd.  
Suite 500  
Bethesda, MD 20814  
301.986.9700  
www.ascouncil.org

### **Cement Plaster/Render**

International Institute for Lath & Plaster  
P.O. Box 3922  
Palm Desert, CA 92260-3922  
760.837.9094  
www.iilp.org

### **Expansion Joints**

Expansion Joints Manufacturers Association  
25 North Broadway  
Tarrytown, NY 10591  
Fax: 914.332.1541  
www.ejma.org

## Section 6: Glossary

**ABSORPTION** – the relationship of the weight of water absorbed to the weight of the dry specimen, expressed in percentages

**AGGLOMERATE TILE** – a man-made stone product generally consisting of either crushed marble, granite or quartz chips with a matrix of resins and mineral pigments. Usually available in assorted sizes as well as large slabs.

**ANSI** – American National Standards Institute

**APA** – American Plywood Association

**ASME** – American Society of Mechanical Engineers

**ASTM** – American Society for Testing and Materials

**BACK-BUTTER** – the spreading of a bond coat to the back of ceramic tile and stone just before the tile is placed

**BACK MOUNTED MOSAIC TILE** – mosaic tile which may have perforated paper, fiber mesh, resin or other suitable material bonded to the back of each tile which becomes an integral part of the tile installation

**BICOTTURA** – method for producing tile by firing it twice (first fire is for body, second is to fuse glazes or patterns in glaze onto the body).

**BISQUE** – the refined mixture of clay, water and additives that has been shaped into the body of a tile

**BODY** – the structural portion of a ceramic tile

**BOND COAT** – a material used between the back of a tile and the substrate. Suitable bond coats for a steam room application include latex portland cement mortar and epoxy adhesive.

**BOND STRENGTH** – a bond coat's ability to resist separating from the tile and underlayment, measured in pounds per square inch (psi)

**BROWN COAT** – the second coat in a three-coat render or mortar application

**BULLNOSE** – a trim tile with a convex radius on one edge

**CAULK** – see sealant

**CEILING SLOPE** – steam rooms require ceilings to be pitched 2" per foot (150mm per m) to prevent condensation from dripping on steam room occupants

**CEMENT** – binding component of mortars and concrete (usually portland cement)

**CEMENT BACKER BOARD** – a backer board, usually composed of cement, fillers and fiberglass mesh, designed for use with ceramic tile in wet areas

**CEMENT GROUT** – a cementitious mixture of portland cement, sand or other ingredients, pigments and water, to produce a water resistant, uniformly colored material used to fill the joints between tile units

**CEMENTITIOUS** – having the properties of cement

**CERAMIC TILE** – a surfacing unit, usually relatively thin in relation to facial area, made from clay or a mixture of clay and other materials called the body of the tile, and having either a glazed or unglazed face

**CHEMICAL RESISTANCE** – the resistance offered by products to physical or chemical reactions as a result of contact with or immersion in various solvents, acids, alkalis, salts, etc...

**CLEAVAGE MEMBRANE** – a membrane that provides a separation and slip sheet between a mortar bed and the substrate

**COLDJOINT** – any point in concrete construction where a pour is terminated and the surface lost plasticity before work continued

**COMPACTION** – the process where a freshly placed mortar is reduced to the minimum practical space to form a stronger, denser mass

**COMPRESSIVE STRENGTH** – a material's ability to withstand a load force, measured in pounds per square inch (psi)

**CONTROL JOINTS** – a joint physically cut into concrete to help control cracking during the curing of the concrete

**CRAZING** – the cracking that occurs in fired glazes or other ceramic coatings due to critical tensile stresses

**CURING** – maintenance of humidity and temperature of freshly placed mortar or grout to assure satisfactory hydration of cement and proper hardening of mortar or grout

**CUSHIONED EDGED TILE** – tile on which the facial edges have a distinct curvature that results in a slightly recessed grout joint

**DEFLECTION** – a variation in the position or shape of a structure element due to the effect of loads or volume change

**DOT MOUNTED MOSAICS** – tile packaged in sheets and held together by plastic or rubber dots between tiles

**EFFLORESCENCE** – the residue deposited on the surface of a material (usually cement grout) by crystallization of soluble salts

**EPOXY ADHESIVE** – an adhesive system that employs epoxy hardening portions

**EPOXY GROUT** – a mortar system that employs epoxy hardening portions

**EXPANSION JOINT** – a joint through tile, mortar and substrate to allow for excessive movement

**FACE-MOUNTED MOSAICS** – mosaic tile sheets that have paper or other suitable material applied to the face of the mosaic sheets, usually with water soluble adhesives for easy removal after installation and prior to grouting

**GLASS MOSAIC TILE** – tile made of glass, usually not over 2" x 2" (50 mm x 50 mm) and 1/4" (6 mm) thick and mounted on sheets. Sheets are typically 12" x 12" (300 mm x 300 mm)

**GLAZED TILE** – tile with a fused impervious facial finish composed of ceramic materials fused to the body of the tile

**GROUT** – a material used for filling the joints between tile

**GROUTING** – the process of filling tile joints with grout

**IAPMO** – International Association of Plumbing and Mechanical Officers

**LATEX PORTLAND CEMENT GROUT** – a mixture of portland cement grout with a latex additive or polymer

**LATEX PORTLAND CEMENT MORTAR** – a mixture of portland cement, sand and a latex additive

**MARBLE TILE** – marble cut into tiles and available in various finishes

## Section 6: Glossary

**MEDIUM BED** – tile setting material that has a finished thickness between 3/8" (9 mm)

**METAL LATH** – expandable diamond metal lath material which is mechanically fastened to a surface and onto which a mortar bed is applied

**MONOCOTTURA** – method of producing tile by a single firing

**MORTAR BED** – the final coat of mortar on a wall, floor or ceiling before the installation of tile

**MOSAIC TILE** – any tile (ceramic, porcelain or stone) with a facial dimension of less than 6 in<sup>2</sup> which usually comes in sheets (paper face mounted, dot mounted, back mounted, etc...)

**MUD** – see mortar bed

**NON-VITREOUS TILE** – tile with an absorption rate greater than 7.0%

**NOTCHED TROWEL** – a trowel with a serrated or notched edge which is used to gauge the amount of mortar or adhesive to a specific thickness when setting tile

**OPEN TIME** – the period of time that a bond coat retains its ability to adhere to the tile and bond the tile to the substrate

**PENCIL ROD** – reinforcing rod with a diameter no greater than 1/4" (6 mm)

**PINHOLES** – imperfections in the surface of tile or grout

**PLASTER** – a cementitious material and aggregate that, when mixed with a gauging liquid, forms a plastic mass or paste which when applied to a surface, adheres to it and subsequently hardens, preserving in a rigid state the form or texture imposed during installation

**PLUMB** – perpendicular to a true level

**PORCELAIN TILE** – a ceramic tile that is dense, impervious and has an absorption rate of  $\leq 0.5\%$

**POT LIFE** – the period of time during which a material maintains its workable properties after it has been mixed

**SCRATCH COAT** – a mortar bed, applied as the first coat of a mortar on a wall or ceiling, whose surface is scratched or roughened so that subsequent mortar coats will bond properly

**SEALANT** – an elastomeric material used to fill and seal expansion and control joints, prevents the passage of moisture and does not allow horizontal and lateral movement to affect the tile installation

**SELF-SPACING TILE** – tile with lugs, spacers or protuberances on the sides which automatically space the tile for the grout joint

**SEMI-VITREOUS TILE** – tile with an absorption rate between 3.0 – 7.0%

**SHELF LIFE** – the maximum period of time that an item can be stored before it is used

**SHOWER PAN** – a waterproof shower floor membrane which is specifically recognized for use in this application – required for steam rooms as well as showers per local building code

**SLAKE** – the process of mixing a cementitious mortar or grout, allowing it to stand for 5 – 10 minutes and then remixing. This process makes sure that the moisture in the mix penetrates lumps in the dry components, making it easier to complete the mixing procedure.

**SLOPE TO DRAIN** – a pitch placed in a floor used to evacuate water. 1/4" per foot (6 mm per 300 mm) is the industry recognized standard for floors.

**SLURRY COAT** – a coat of thin-set used to bond a mortar bed to a cementitious substrate

**SPACERS** – plastic or rubber units used to separate and provide consistent spacing between tiles

**STATIC COEFFICIENT OF FRICTION (COF)** – the degree of slip resistance presented in a quantitative number that expresses the degree of slip resistance on the face of tile

**STEAM GENERATOR** – mechanism that turns water into steam and pumps the steam into the steam room under pressure

**SUBFLOOR** – a rough floor, plywood or boards, laid directly on joists and to which an underlayment or substrate is installed

**SUBSTRATE** – the underlying material to which a tile installation is bonded

**TCNA** – Tile Council of North America

**THICK BED MORTAR** – a thick layer of mortar that is used for leveling (see mortar bed)

**THIN-SET** – tile setting material that has a final thickness not greater than 3/8" (9 mm)

**VAPOR BARRIER** – an impervious sheet material that is placed under the substrate to prevent moisture vapor from transgressing through a wall, ceiling or floor

**VITREOUS TILE** – tile with an absorption rate of between 0.5 – 3.0%

**WALL TILE** – a glazed tile with a body that is suitable for interior use only and has an absorption rate of greater than 7.0%

**WATERPROOFING MEMBRANE** – a material applied to a substrate before tiling to protect the substrate and supporting structure from damage by water

**WET AREA** – surfaces that are either soaked, saturated, or regularly and frequently subjected to moisture or liquids (usually water), such as saunas, steam rooms, showers, swimming pools, and more

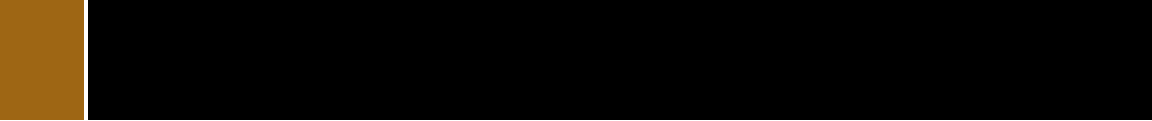





**Innovative Tile and Stone  
Installation Systems**

Corporate Headquarters:  
LATICRETE International, Inc.

One LATICRETE Park North  
Bethany, CT 06524-3423 USA  
1.800.243.4788  
+1.203.393.0010

[www.laticrete.com](http://www.laticrete.com)

Asia Pacific: +852.2526.6660

Australia: +61.3.9933.6111

China: +86.21.5789.3300

Eastern Europe: +790.9661.1644

Europe: +34.96.649.1908

India: +91.40.3041.3100

Latin America: +1.203.393.0010

Middle East: +971.7.244.6396

South East Asia: +65.6515.3028

**DS-125.0-1109**

©2009 LATICRETE International, Inc.  
LATICRETE, LATAPOXY, SPECTRALOCK and the  logo are Registered Trademarks of LATICRETE International, Inc.

Microban is a registered trademark of Microban Products Company.  
Kavlar is a registered trademark of Dupont Products Company.  
GREENGUARD Indoor Air Quality Certified® Product.