

## COMMERCIAL & RESIDENTIAL SAUNA SPECIFICATIONS

### CONDENSATION

A sauna is a **HIGH HEAT, LOW HUMIDITY** environment. The humidity in a sauna is between 10-20%. This is the case even if water is used. The sauna heater in actuality bakes the air inside the sauna, drying it out. When water is added over the sauna rocks, there is a blast of steam, but it dissipates immediately. A sauna should not be confused with a steambath where a generator produces steam and humidity is high. A sauna does not require an exhaust vent.

### WET/DRY SAUNA

There is no such thing as a wet sauna as opposed to a dry sauna. A sauna is a high heat, low humidity environment. Water is not required in a sauna, but it is a preferred method of use. It makes the air more breathable and increases the "feeling" of heat. This is accomplished by splashing some water on the rocks. For splashing water on the sauna rocks, a sauna bucket and ladle are ideal.

In commercial saunas, it can be difficult to control the amount of water used. Excessive water will affect the heater and require more maintenance. Many commercial installations pull out the water supply. This is seldom effective in preventing water abuse as saunas are invariably installed in a bathroom/shower area where water is readily available.

### OPERATING COST

Saunas are very inexpensive to operate. A residential sauna is only on for an hour or so at a time once or twice a week. The cost for electricity is about 7 cents per kilowatt hour. A sauna with a 6,000 watt heater would cost about 40 cents per use.

### DRAIN:

Commercial saunas should have a drain in center of floor area, with the floor to be sloped to drain. A residential sauna should also have a drain, but it is not essential. Water should be used only in moderation. It is splashed on the rocks and evaporates. A residential sauna gets comparatively light use and water can be controlled. Drains are still recommended, but they are not essential. so there may not be need for a drain.

### CURB:

A commercial sauna floor should have a curb, 3" x 3" (76mm x 76mm) high around perimeter of sauna, excluding the door opening. A curb is not required in residential saunas, however, if the floor is tiled a tile base is recommended.

## **FLOOR BASE:**

A variety of surfaces may be used for a sauna floor.

### **Commercial**

Floor to be a non-slip ceramic tile over the floor and up the face of the curb. A water membrane (or pan) should be installed

### **Residential**

Tile is also recommended, however it is also acceptable to have concrete (i.e. house basement). Where the sauna is on a floor other than the basement (i.e. master bedroom) tile should be installed over the wood sub-floor. A water membrane (or pan) should be installed..

## **VENTING**

### **EXHAUST**

There is very little condensation from a sauna, so an exhaust vent is not necessary.

### **UNDERCUT DOOR**

undercutting the door is one way to bring in fresh air and create air movement. In many cases, this is sufficient. But with certain situation and with certain heaters cross venting is require.

We undercut all our doors.

### **CROSS VENTILATION / FRESH AIR**

#### **Inlet**

Cross ventilation consists of an intake vent below and behind the sauna heater. This vent can be adjustable, however since access to this vent is limited once the heater is in place, this vent is generally not adjustable. Usually, it consists of holes being drilled in the cedar through the exterior. A grill should be placed over the inlet opening on the outside of the sauna to match the exterior decor. This grill may be adjustable if desired.

#### **Outlet**

The outlet vent should be located diagonally across the sauna high on the wall or on the ceiling. The simplest means is install the vent as done with the inlet; directly through the wall into the exterior. However, often the outlet vent wall does not allow for direct venting; i.e. outside wall of home or commercial installation with an obstruction on the other side of the wall. In this case, a duct can be run from the outlet through the stud wall, to the ceiling cavity and out. The duct should carry through to an outlet vent in the saunas drop ceiling. Simply venting to the area over the sauna ceiling is possible, but not preferred because there is loose insulation in this area. Commercial saunas can be vented to unconditioned space.

### **ABOVE THE SAUNA**

In commercial saunas with a drop ceiling, the area above the sauna must be vented to avoid the possibility of a vacuum area where heat can build up and create problems. Residential saunas are not on long enough to create this problem. A vent at this spot is not required unless the outlet vent of the sauna (see above) was vented into the ceiling cavity.

## **HEIGHT RESTRICTIONS**

The standard residential height for a sauna is 6'-11-1/2" (210mm). This is more than sufficient to allow for a standard two tier bench. This height is the most efficient as it limits the cubic area and it keeps the warmest air closer to the sauna users. Commercial saunas are usually 7' (2134mm) Under no circumstances should a sauna be higher than 8'-0" (2440mm). Minimum height for sauna heaters up to 9,000 watt is 6'-6" (1983mm). For heaters 12,000 & larger, minimum height is 7'-0" (2135mm).

## **FRAMING:**

The of walls and ceiling are constructed of 2" x 4" (50mm x 100mm) kiln-dried, construction grade spruce studs, at 16" (400mm) O.C. Saunas up to 8' x 8' are generally lined horizontally. The wall studding should run vertically.

Due to the limited availability of longer lengths of quality clear cedar, commercial and larger residential (over 8' x 8') saunas are lined vertically.

Metal studs may be used. 1" x 2" (25 x 50) spruce strapping will be required to provide a nailing surface for the cedar

We recommend against cedar for framing. There are acids present in cedar which eat away at the finishing fasteners, irrespective of the type of fastener. As a result, it is best to have the cedar fastened to spruce framing or strapping.

## **STRAPPING:**

The studs should be strapped over the foil vapour barrier using 1" x 2" (25mm x 50mm) spruce. This done for a number of reasons: It prevents the vapour from being perforated by the fasteners used to attach the cedar. It also adds an insulating layer and prolongs the life of the cedar by preventing the foil from reflecting heat directly back into the cedar.

## **ELECTRICAL:**

All electrical rough-in wiring for sauna heater, control and light and installation of sauna controls should be done at this time, before sauna is lined.

Sauna equipment manufactured by Finlandia / Saunafin (phone: 905-738-4017).

## **PLUMBING:**

If the sauna is to have a water supply or sprinkler, the plumbing should be installed at this time. **NOTE:** Water taps should not be located over the sauna heater.

## **INSULATION**

The perimeter walls and ceiling to be insulated with 3 1/2" (89mm) fiberglass batts, having a R-12 insulation rating. Note: Styrofoam insulation does not have a sufficient heat rating to withstand the temperatures in saunas.

## **VAPOR BARRIER:**

Use kraft backed aluminum foil on the inside edge face of studs, on the walls and ceiling.

## **CEDAR LINING:**

Interior walls and ceiling to be 1" x 4" (25mm x 100mm), SAUNA-SELECT GRADE (also known as Grade "A" & better, clear), tongue & groove, kiln-dried, Western red cedar. The cedar should be left 1"- 2" (25mm-50mm) off the floor so as not to draw up any excess water which may accumulate.

There should be no seams on the walls or on a ceiling with a span of 8 feet (2440mm) or less. The tongue & groove cedar should be fastened using 1-1/2" galvanized finishing nails or brads. The cedar should be installed using a "blind nailing" technique. It should be nailed through the tongue only in order to conceal the nails behind the groove of the adjoining piece of cedar.

**NOTE:** 1" x 6" (25mm x 150mm) cedar is not recommended. Because it has a larger surface area it is affected more by the extreme dry environment. It is more likely to shrink and cup than 1" x 4" (25mm x 100mm) cedar.

### **Residential**

The common and most popular approach is to line walls HORIZONTALLY. Due to the limited availability of longer lengths of clear cedar, saunas over 8' x 8' are lined vertically.

### **Commercial**

Commercial saunas are generally lined vertically.

## **EXTERIOR:**

There is no special requirement for the exterior walls of a sauna. The exterior walls may be drywall, cedar, paneling, tile or concrete block.

## **BENCHES:**

Bench framing and seating surface are constructed of 2" x 4" (50mm x 100mm) kiln-dried, SAUNA-SELECT GRADE western red cedar, dressed four sides, laid flat, with 1/2" (12mm) spacing between the boards.

The benches should run along the long wall if possible to maximize seating capacity. If additional bench space is required, an L-shaped bench arrangement can be used. Add a one or two tier "L" return bench along the side wall. The "L" bench is butted up to the back bench. For "L" benches, it is generally advisable to locate the door in the middle of the long wall, with the heater on one side of the door and the return bench on the other side. (NOTE: In a sauna, seating capacity is more important than floor space. The goal is to maximize the bench space, and minimize cubic area.)

For a height of 7'-0" (2135mm) or less, there will be a two tier bench: Top tier 20" (500mm) deep and the bottom bench 16" (400mm) deep, with 18" (450mm) risers. (If the sauna is 8'-0" (2440mm) high, a three tier bench may be used: Top tier 20" (500mm) deep, middle tier 20" (500mm) deep and the bottom bench 16" (400mm) deep, with 18" (450mm) risers .

The risers between the benches should be left open. This facilitates cleaning the floor under the benches. It also gives the sauna a more open look and spacious feel. The benches should be fastened from the bottom ("blind nailing") using 2-1/2" decking or stainless steel screws.

## **DOORS:**

### **Residential**

Cedar framed full-length glass door with 16" x 64" window. Window is insulated thermopane tempered unit. Includes cedar handles and a nylon roller latch. The door will open out and will be undercut about 1" (25mm). 5/8" x 4-9/16" engineered jambs for added strength and durability. Rough opening size 26" x 76 1/2" (660mm x 1930mm) Door size of 24" x 74" (600mm x 1880mm).

### **OPTIONS:**

- a) **STANDARD STYLE GLASS DOOR - DIFFERENT GLASS COLOR**
  - i. **Obscure**
  - ii. **Bronze**
  - iii. **Designer Sandblast**

- b) **SOLID CEDAR DOOR WITH 12" X 24" WINDOW**

### **Commercial**

Door made of a kiln-dried, Western red cedar frame, WITH 16" X 64" TEMPERED INSULATED DOUBLE PANE WINDOW INSULATED DOUBLE PANE SAFETY GLASS WINDOW, hydraulic door closer and pull handle. Door to be undercut 1" for ventilation. 5/8" x 4-9/16" engineered jambs for added strength and durability. Standard commercial door- Door Size= 28" x 78". Rough Opening size= 30" x 80"

### **OPTIONS:**

Handicapped Accessible door- Door Size= 36" x 78". Rough Opening size= 38"-1/2 x 80"

Custom sized to suit

**NOTE:** Hardwood is preferred over cedar. Cedar is a soft material and hinges can loosen in

time. Doors mounted on hardwood jambs last longer .

## **CEDAR FLOOR**

As a option, there may be a slatted cedar ("duck board") floor on walking area only, it does not go under the benches or under the heater.

### **Residential**

1" x 4" (25mm x 100mm) clear cedar spaced 1/2" (12mm), over cedar sleepers spaced 12" (300mm), sitting on 1/2" (12mm) rubber dome supports, random spaced to allow free flow of water to drain. Floor may be sectionalized for easy removal for cleaning.

### **Commercial**

2" x 4" (50mm x 100mm) clear cedar 1/2" (12mm) spaced, over 2" x 4" (50mm x 100mm) cedar sleepers, spaced 12" (300mm), sitting on 1/2" (12mm) rubber dome supports, random spaced to allow free flow of water to drain. Floor may be sectionalized for easy removal for cleaning.

## **LIGHT:**

The lights are vapour proof, surface mounted on the wall.

Wall mounted lights are recommended for residential saunas and all saunas 7'-0" high or less.

### **Residential**

Benches up to 6'-0" in length are to be built using wall cleats (supports). The cleats are fastened through the cedar lining into the stud frame. The benches are suspended from the cleats. Saunas are relatively confined spaces. Using wall supports gives the sauna a more open and uncluttered appearance. Saunas over 6'-0" in length should have one centre floor support.

### **Commercial**

Due to more extensive use, commercial; sauna benches are framed using only floor supports. Supports should be installed no further than 4'-0" on centre with girths (braces) installed 2'-0" on centre. Due to the excessive wear, for health clubs (as opposed to condominiums & hotels), floor supports should be installed 3'-0" on centre.

## **HEATER GUARD:**

### **Residential**

The heater guard fence is to be constructed of 2" x 2" (50mm x 50mm) vertical posts with 1" x 4" (25mm x 100mm) rails. To be constructed of kiln-dried, SAUNA-SELECT GRADE cedar. Guard fence to extend 6" (150mm) above heater.

### **Commercial**

The heater guard fence is to be constructed of 2" x 4" (50mm x 100mm) vertical posts with two 2" x 4" (50mm x 100mm) rails on each side. To be constructed of kiln-dried, SAUNA-SELECT GRADE cedar. Guard fence to extend 6" (150mm) above heater.

## **MOLDING:**

Install 5/8" x 5/8" (16mm x 16mm) cedar molding in corners and at

## **ceiling. CASING:**

Inside of door to be cased with 1" x 3" (25mm x 75mm) or 1" x 4" (25mm x 100mm) SAUNA-SELECT CEDAR, kiln-dried, dressed 4 sides (square edge). Outside to be cased to match the exterior decor.

## **FASTENERS:**

The tongue & groove cedar should be fastened using 1-1/2" galvanized finishing nails or brads. The benches are to be built using 2-1/2" , decking or stainless steel screws.

**HEATER:**

Model no. \_\_\_\_\_

240 volt     208 volt

single phase     Three phase

As specified and supplied by: **Saunafin**

Phone: 905-738-4017 / 800-387-7029  
Fax: 905-738-4017  
E-mail: [sales@saunafin.com](mailto:sales@saunafin.com)  
Web: [www.saunafin.com](http://www.saunafin.com)

See heater specifications for size requirements and clearance

restrictions. **CONTROLS:**

There are a variety of controls available for saunas (see heater literature and specifications). Please note that many jurisdictions require saunas to have a 60 minute timer to shut down the sauna automatically after one hour.

**Residential**

The ideal location is recessed in the front exterior wall of sauna next to the door. The TPT-3 Control mechanical control with thermostat, pilot light and 60 minute spring timer . EL-13 Electronic Control - Pus button control of time (60-minute max.) and temperature. These icontrols installed installed in a 3 gang masonry electrical box (included).

If a contactor is required, it is best to install it in the electrical room.

**Commercial**

Some use the Residential control.

**FSA-421 Commercial Control with timer**

To prevent public access to thermostat, control can be separated.

Stand-alone FSA-421 electronic control (and magnetic contactor) installed away from sauna (i.e. equipment or electrical room).

A 60-minute spring timer is installed in the wall next to the sauna door (one gang box-not included)

## **PRESERVATIVE:**

### **Residential**

**We recommend leaving the cedar natural, unless the home owner plans to use excessive amounts of water. All preservatives will mask the pleasant scent of the cedar.**

### **Commercial**

**Treat wood interiors of sauna with water based FINLANDIA / SAUNAFIN CEDAR PRESERVATIVE. To be applied to walls, ceiling, benches, door, guard fence and wood floor. It will help prevent water staining and protect the cedar from long term heat exposure. It is also acceptable to use oil based penetrating preservatives, i.e. danish oil. Sealants such as varathane should not be used.**

## **ACCESSORIES**

**There is a large selection of practical and enjoyable sauna accessories. Some of the more popular are: wood bucket and ladles, thermometers, sauna essence, head rests and towel racks.**

## **INSTALLATION**

**Install all materials square, plumb, straight and accurately**

### **fitted. CLEAN UP**

**On completion of the work on this section, all surplus materials, debris, tools and equipment shall be removed from the premises and the site left in a condition satisfactory to the general contractor/owner.**

## **Saunafin**

**Phone: 905-738-4017 /**

**800-387-7029 Fax:**

**905-738-4017**

**E-mail: [sales@saunafin.com](mailto:sales@saunafin.com)**

**Web: [www.saunafin.com](http://www.saunafin.com)**



# A LITTLE INFO ABOUT SAUNAS

## WET/DRY SAUNA

Saunas are by nature a dry environment. Water is not required in a sauna, but it is recommended. It makes the air more breathable and increases the humidity, which intensifies the "feeling" of heat. This is accomplished by splashing some water on the rocks.

## CONDENSATION

A sauna is a **HIGH HEAT** (176-194<sup>0</sup>F), **LOW HUMIDITY** environment. Interior ambient humidity in a home is generally 40-50%. The humidity in a sauna is between 10-20%. The sauna heater is actually baking the air inside the sauna. When water is added over the sauna rocks, there is a blast of steam, but it dissipates quickly.

## STEAM SAUNA or STEAMBATH

Many people use the expression steam sauna. Most are referring to a steambath as opposed to sauna. A sauna should not be confused with a steambath. A steambath or steam sauna has a steam generator located outside that produces steam and pipes it into the room. A steambath has humidity at or close to 100%. Despite the relatively lower temperature (100-120<sup>0</sup>F), the room feels very hot because of the ambient humidity.

## OPERATING COST

Saunas are very inexpensive to operate. Temperature is irrelevant; the cost of electricity is based strictly on time usage. A residential sauna is on for about an hour, once or twice a week. The average cost for electricity is 7-9 cents per kilowatt-hour. A sauna with a 6 kw heater would cost 40-50 cents per use.

## DRAINAGE

Commercial saunas should have a drain in center of floor (sloped to the drain) area to facilitate cleaning. Most residential saunas have drains, but it is not essential. Water should only be used in moderation. It is splashed on the rocks and evaporates.

## WATER SUPPLY

A permanent water supply is not required. Under no circumstances should a water tap be directly over the heater. A sauna bucket and ladle are the preferred method for applying water to the sauna rocks.

## FLOOR

For residential, tile is attractive and functional; however it is also acceptable to have concrete or a PVC waterproof floor covering over a concrete or wood sub-floor. For commercial installations we recommend a non-slip ceramic tile over the floor and up the face of the curb. A removable "duckboard" cedar floor can be placed



## HEIGHT

The standard height for a sauna is 82-1/2" . This is more than sufficient to allow for a standard two tier bench. This height is the most efficient as it limits the cubic area and it keeps the warmest air closer to the sauna users. The height should never be greater than 8'-0".

## SAFEGUARDS

All heaters are equipped with a thermostat to regulate the temperature and a 60-minute timer to automatically shut down the sauna after one hour. There is also a built-in high temperature cut-off to prevent overheating.

## VENTING

### Exhaust

There is very little condensation from a sauna, so an exhaust vent is not necessary.

### Cross Ventilation / fresh air

Install an inlet vent behind the heater and an outlet high in the far corner under the top bench. Depending on the sauna location, i.e. outside wall, placing vents through the wall may not be practical. See Vent detail page for other options

# Vent Details

## A NOTE ON VENTING:

Proper sauna venting is an important part of sauna heater operation and to effectively heat the sauna room. Sauna ventilation is passive. There is no mechanical fan. It is not part of the HVAC or bathroom exhaust.

**INLET** goes low behind heater (usually on front wall). Typically, it is simply holes drilled through cedar on sauna side.

Fixed cedar grill (in lieu of holes) is available as option.

Exterior has aluminum grill (not included) to match exterior decor.



Fixed cedar grill:  
Optional with LK Plus  
Incl with LK Premium

**OUTLET** located high on wall diagonal from inlet

Cedar slide cover on outlet (sauna side).

Exterior has aluminum grill (not included) to match exterior decor.

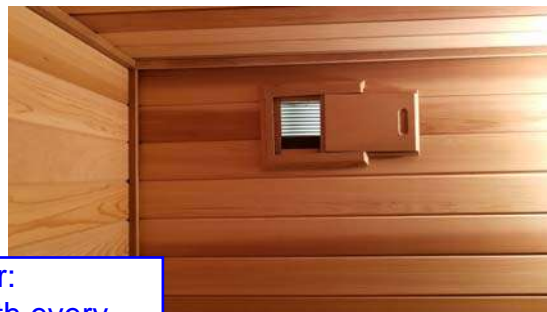
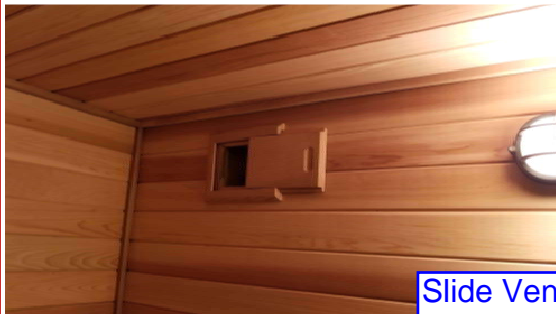

Slide Vent Cover:  
One included with every  
sauna material kit



Exterior Grill:  
Not Included  
Select to match your decor

# Slide Vent Cover

If outlet is exterior wall, you must run duct or construct a chase through stud cavity and over drop ceiling. Exhaust into room in front of sauna.

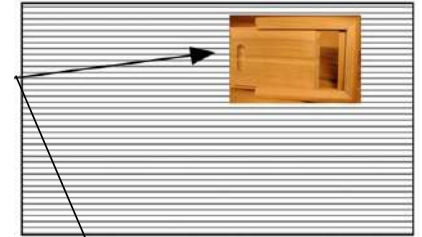
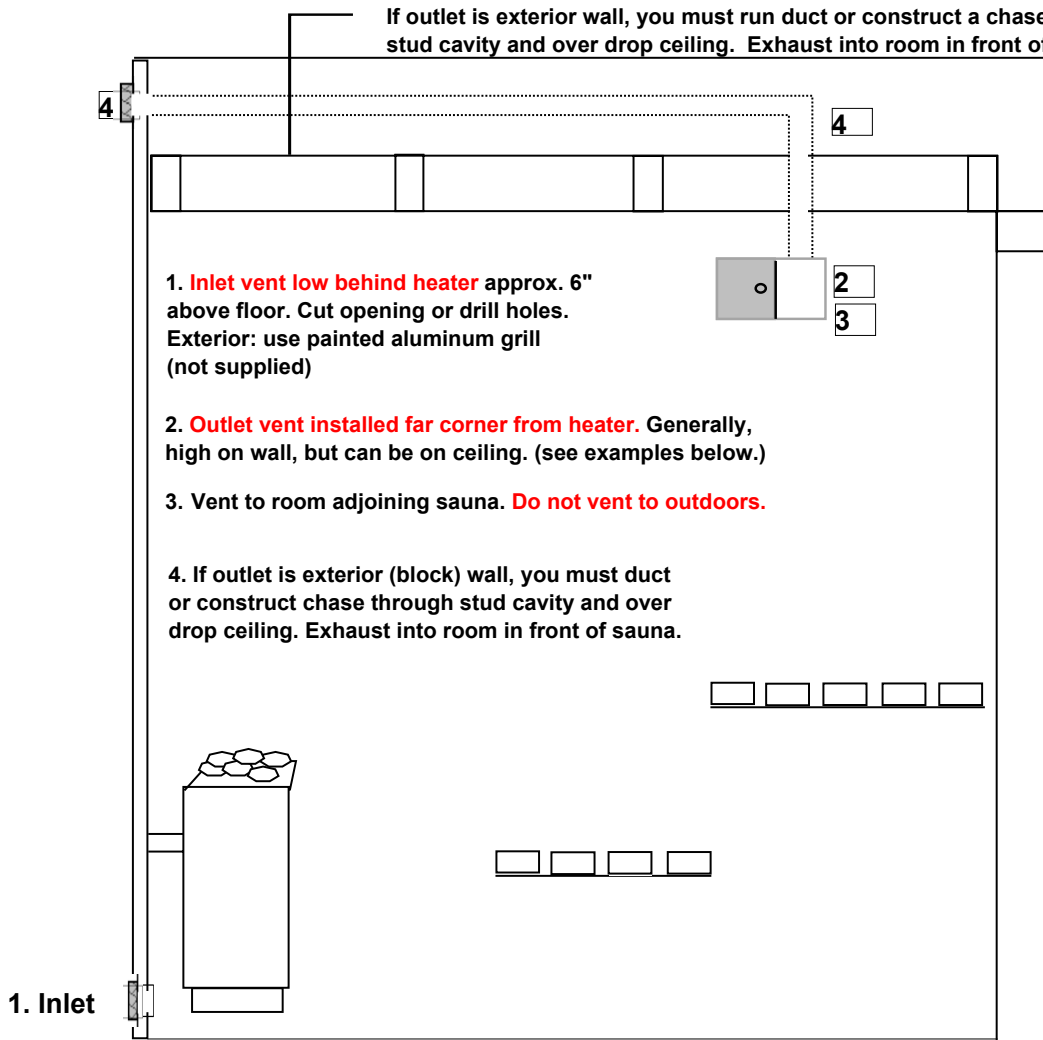

Slide Vent:  
Vent when open = 7" x 13"  
Wall opening = 4.5" x 4.5"

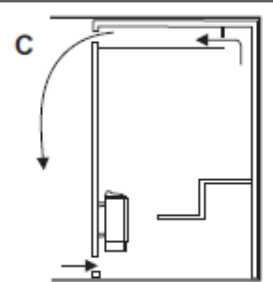
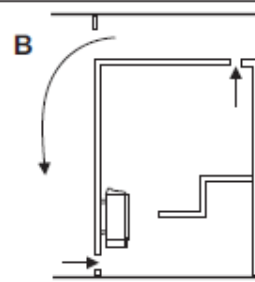
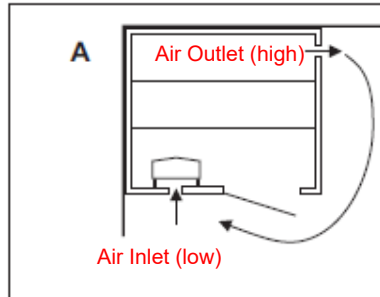
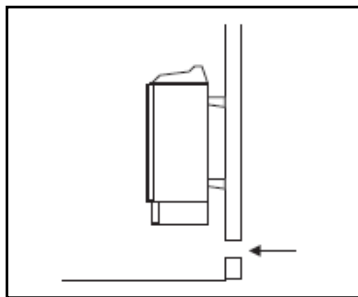
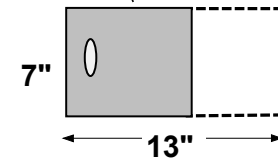

The inlet vent should be driven straight through the wall directly below the center of the heater. The cross-section of the vent for a wall mounted sauna is approx. 19 sq.in. For larger saunas approx. 40 sq.in

**Position the air inlet and outlet vents as far away from one another as possible (diagonally opposite).** The outlet vent should be located high on a wall or in the ceiling, and should have the same cross-section area as the inlet vent. Spent air should always be led back into house – it should not be discharged directly to the outside. Do not install inlet and outlet vents on same wall. Bad ventilation can be worse than no ventilation.

A: Outlet vent through the sauna wall (seen from above). The vent is placed high up, near the ceiling.

B: Outlet vent through the cavity above the sauna ceiling (seen from the side).

C: Outlet vent through a drum under the ceiling in the sauna (seen from the side). The outlet duct should be placed at an angle between the ceiling and the wall. The drum can be built of wooden panelling and have the same area as the outlet vent.

Inlet: If drilling holes for inlet, must equal specified sq inch requirement. Six 2" or eight 1.75" holes are sufficient.

# Commercial Saunas

# COMMERCIAL SAUNA SECTION - VERTICAL

Sauna Side View, Metal Stud, Tile Base

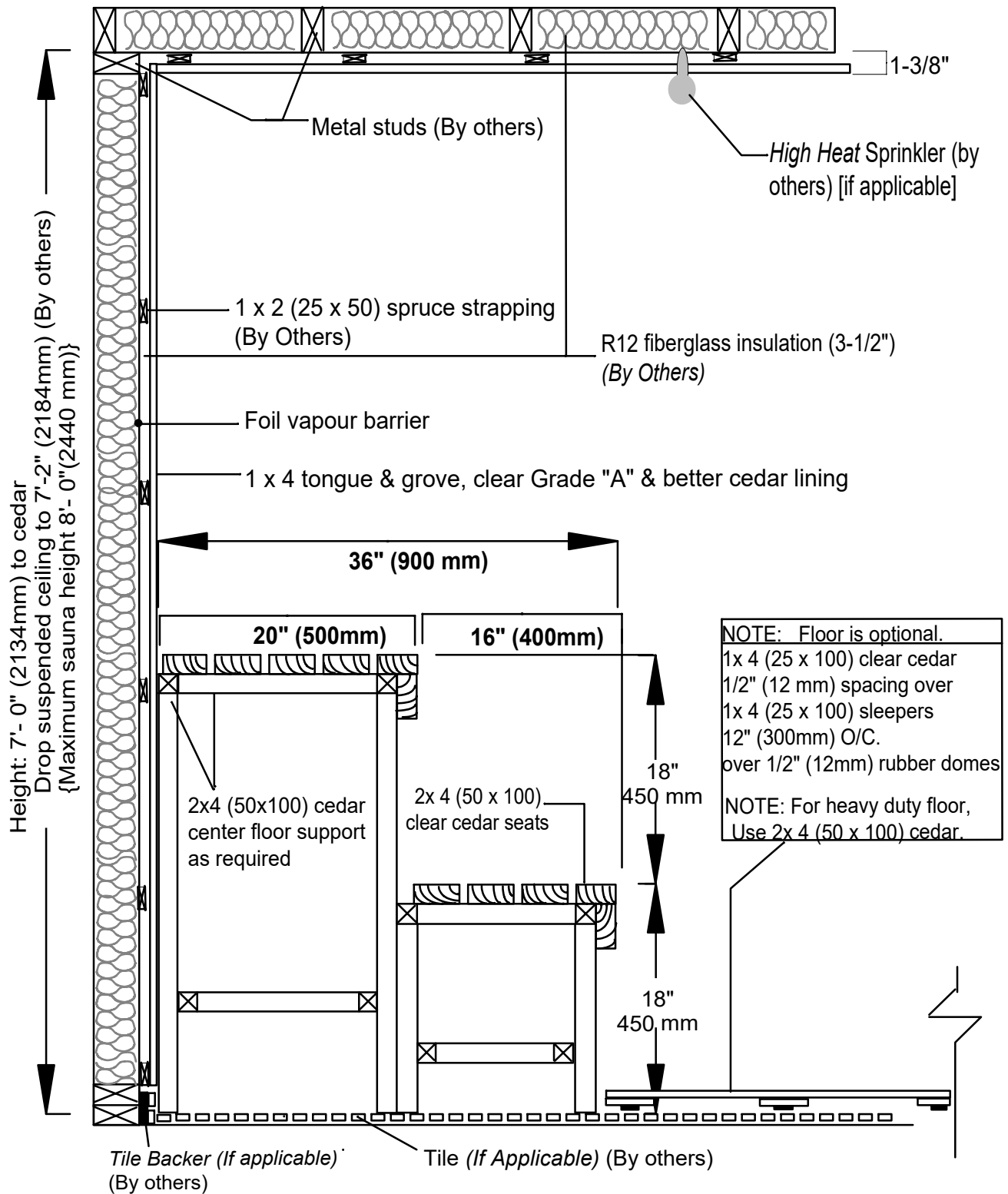

**VERTICAL LINING WHERE SPECIFIED. CHECK YOUR MATERIAL LIST TO VERIFY YOUR LINING**

**SIDE VIEW CROSS SECTION  
(FOR SAUNAS LINED VERTICALLY) (NOT TO SCALE)**

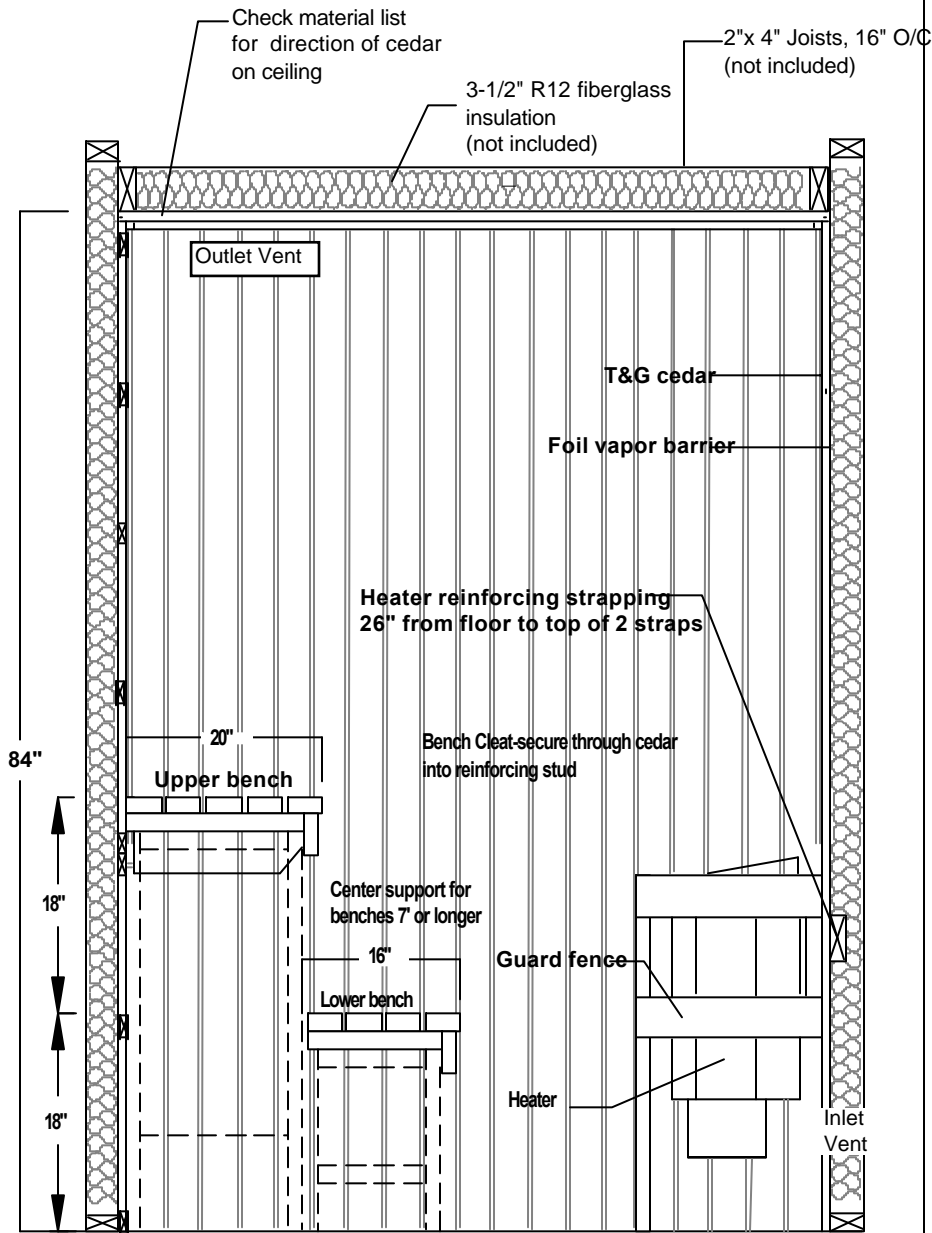

**TOP VIEW CROSS SECTION  
(FOR SAUNAS LINED VERTICALLY) (NOT TO SCALE)**

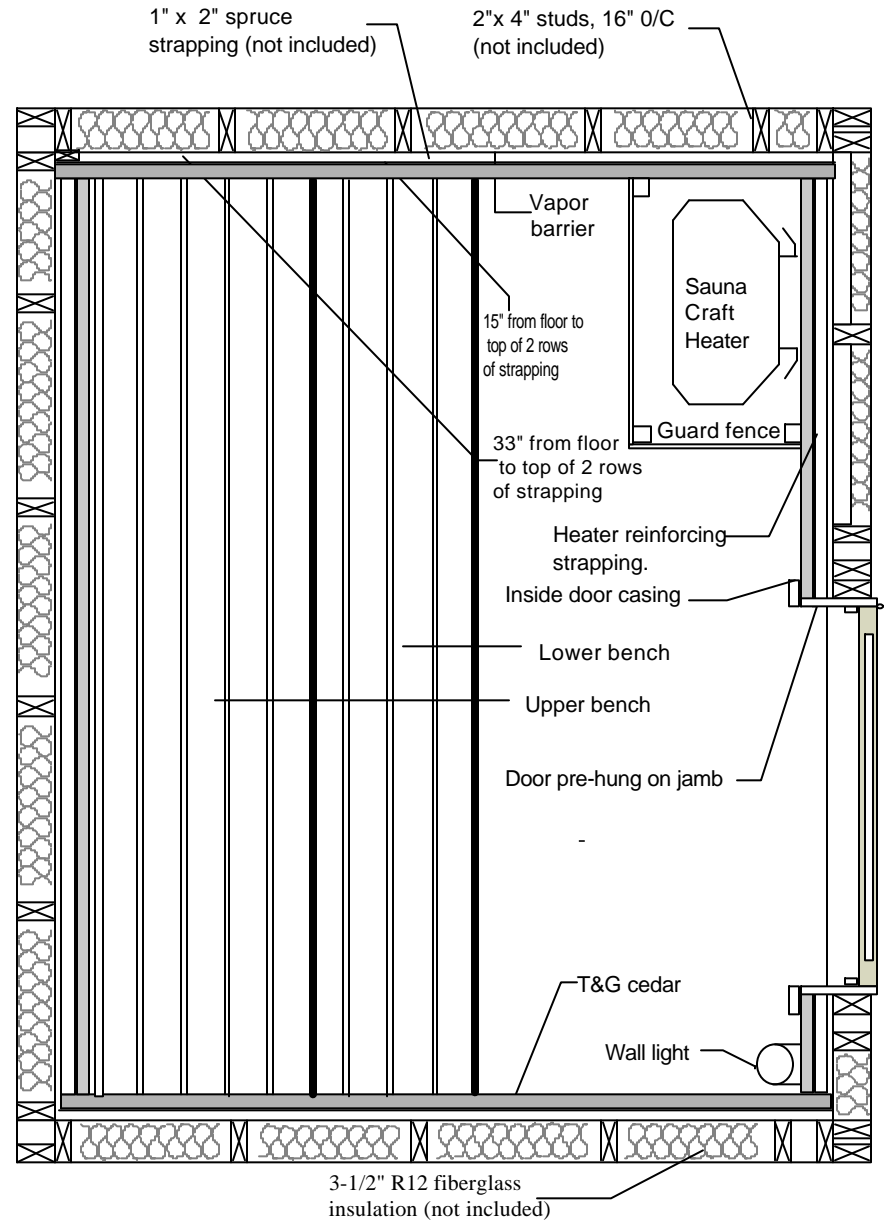

**NOTE: This drawing is generic and does not necessarily reflect your exact sauna. Check your Sauna Material List for specifics on you sauna.**

# COMMERCIAL SAUNA SECTION - HORIZONTAL

## Sauna Side View, Metal Stud, Tile Base

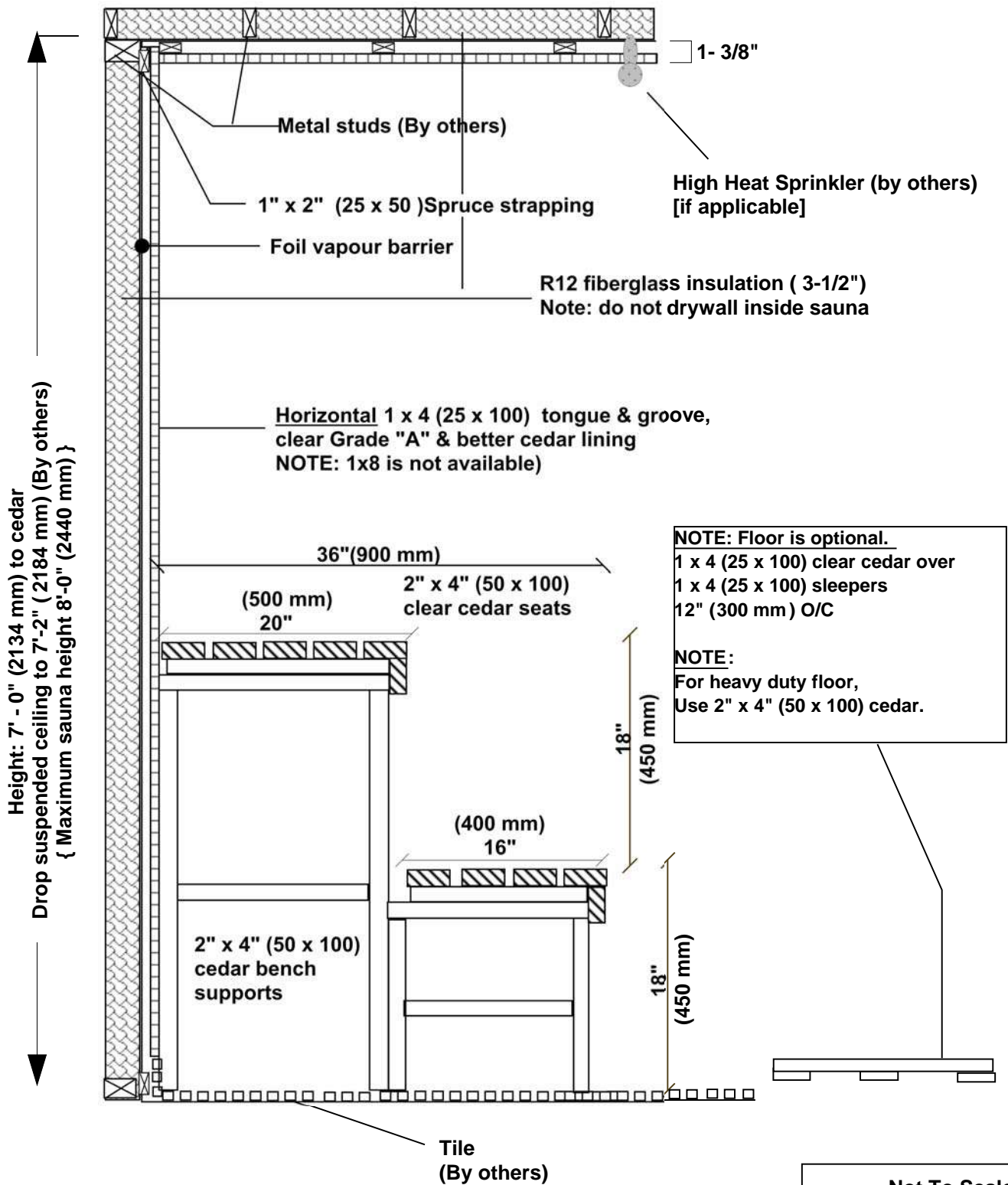

# HORIZONTAL LINING IS STANDARD. CHECK YOUR MATERIAL LIST TO VERIFY YOUR LINING

#1

## SIDE VIEW CROSS SECTION

(FOR SAUNAS LINED HORIZONTALLY) (NOT TO SCALE)

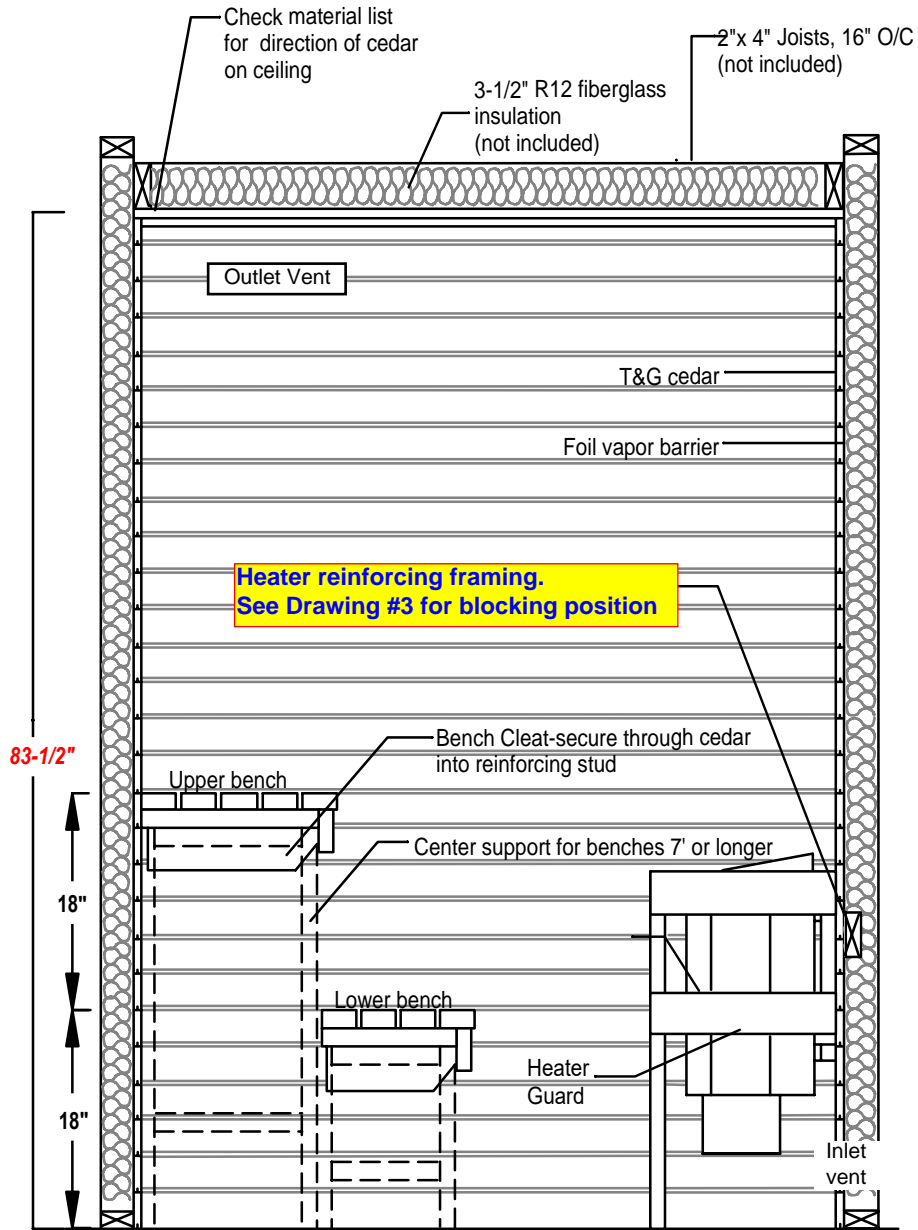

## TOP VIEW CROSS SECTION

(FOR SAUNAS LINED HORIZONTALLY) (NOT TO SCALE)

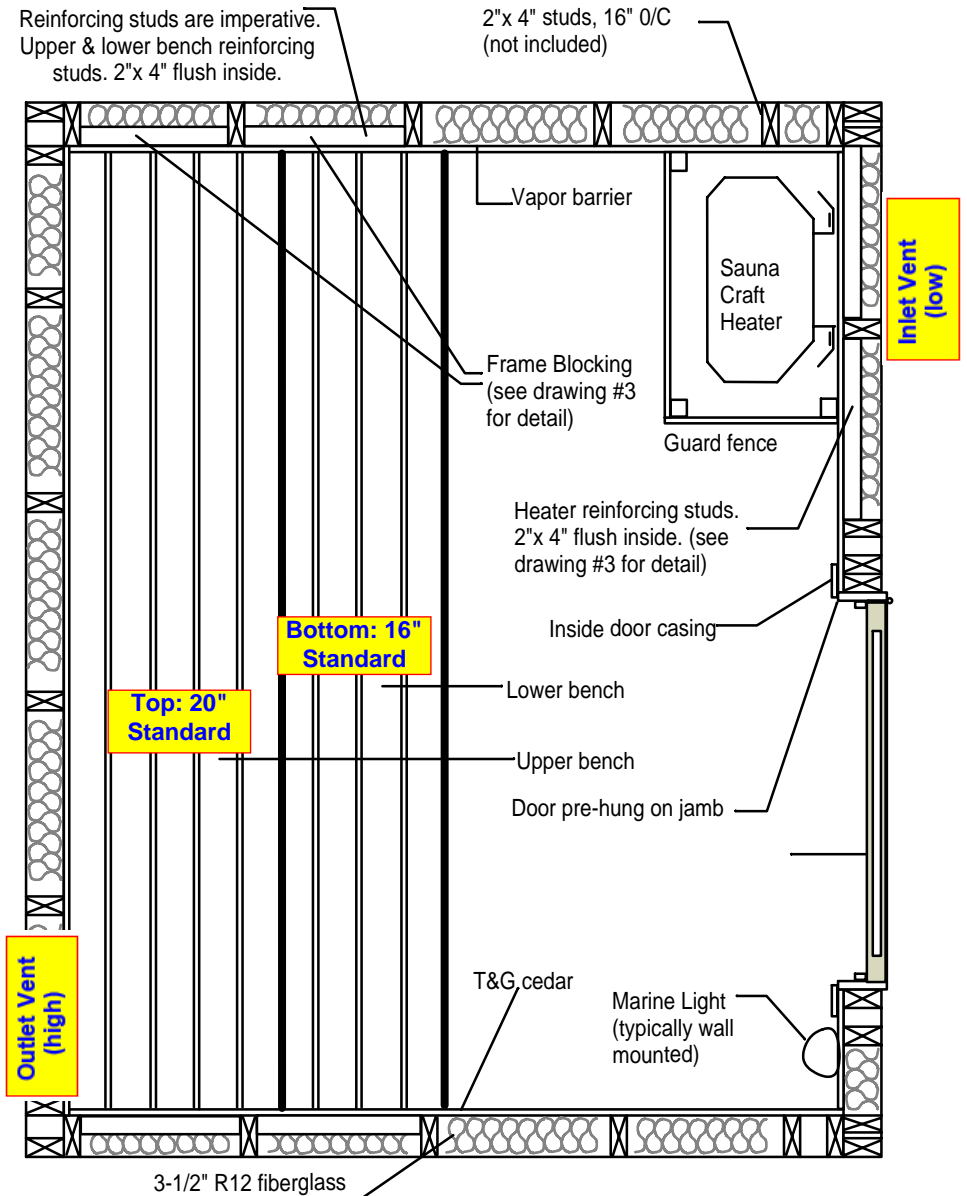

**NOTE: This drawing shows standard sizes & dimensions. It may not reflect your exact sauna. Check your Material List for specifics for your sauna**



# Wall Lining - Seamed (where required or specified)

## Staggered Horizontal



Horizontal staggered seam.

## Horizontal



middle Seam with  
trim to conceal

## Vertical



Seam Concealed Behind Benches  
and "chair rail" style trim molding

**GLASS SAUNA DOOR - COMMERCIAL**  
**Cedar Framed, Tempered Thermal Pane Window**

Use "Tyle Control" App on  
(Android, Apple or Google play)

End caps

2" x 4" (25 x 100 mm) tongue & groove  
solid cedar

Window: 16-3/4" x 64"  
4 mm clear tempered  
double pane insulated glass

5/8" x 4 - 9/16"  
mahogany jamb



gap under door (approx. 3/4")

**Standard R/O = 30" x 80-1/2"**  
**Standard Door = 28" x 78"**

# SAUNA DOOR - ADA COMPLIANT

## Cedar Framed, Tempered Thermal Pane Window (16 x 64)

End caps

2" x 4" (25 x 100 mm) tongue & groove  
solid cedar

Window: 16-3/4" x 64"  
3 mm clear tempered  
double pane insulated glass

5/8" x 4 - 9/16" Jamb

Plywood backing on hinge  
side for reinforcement

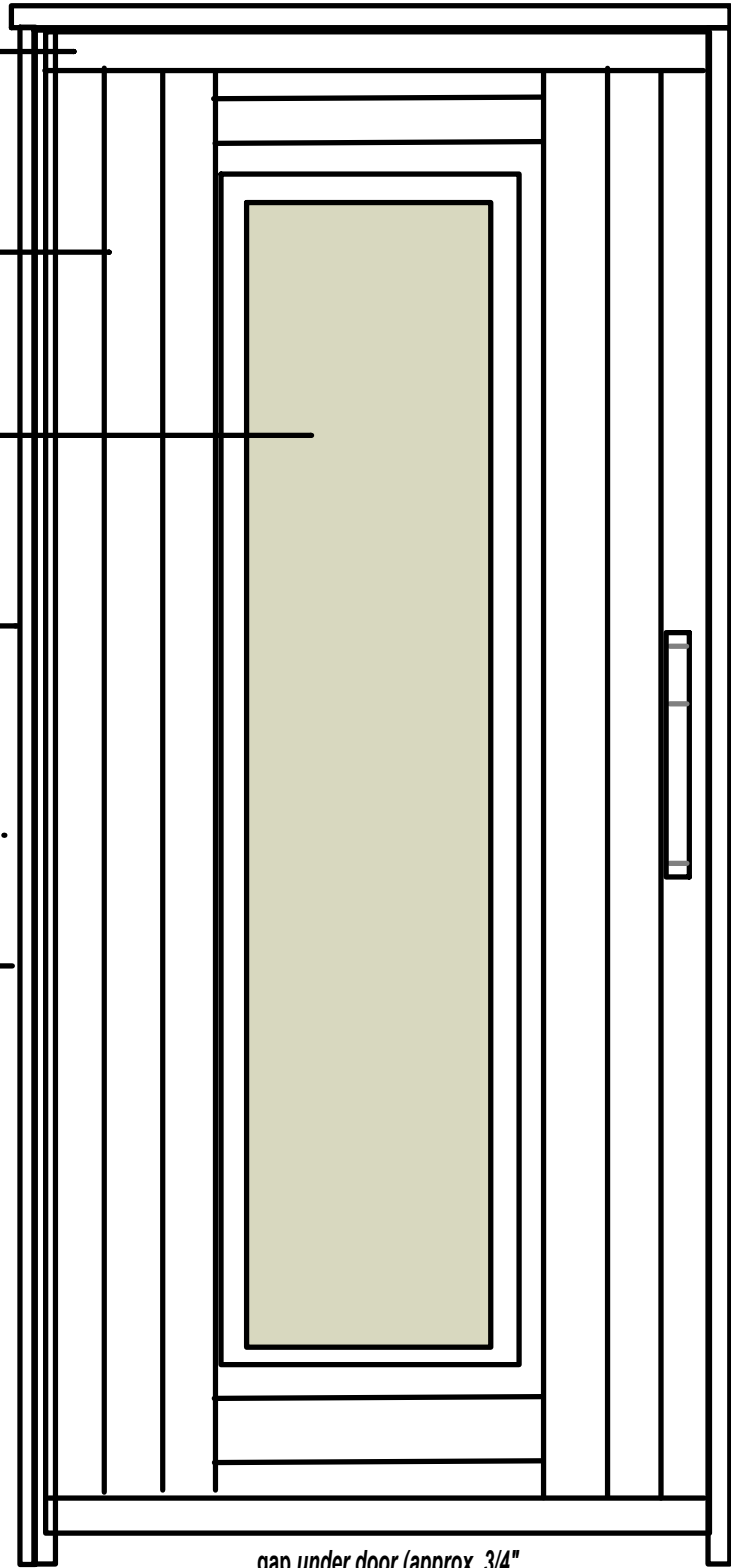

gap under door (approx. 3/4")

**Standard R/O = 38-1/2" x 80"**  
**Standard Door = 36" x 78"**

# HEATER GUARD FENCES

## 2S Two Sided (Heater on flat wall in corner)

- 2 @ 18" 2X2
- 1 @ 36" 2X2
- 4 @ 24" 1X3

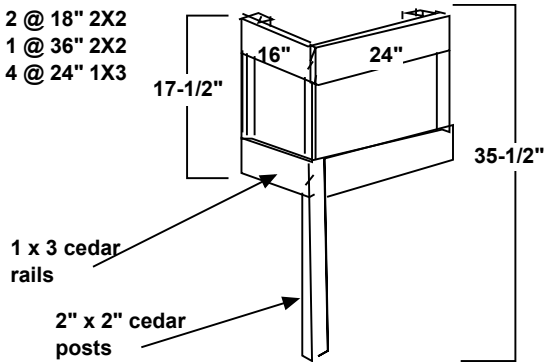

## 3S Three Sided (Heater flat wall - Not in corner)

- 2 @ 18" 2X2
- 2 @ 36" 2X2
- 6 @ 24" 1X3

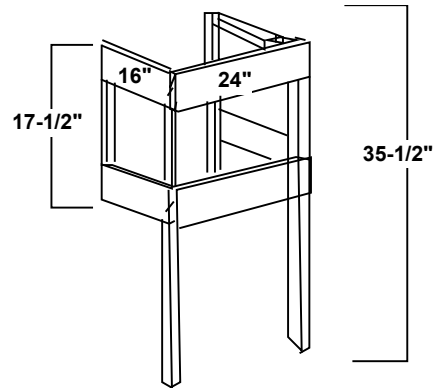

## 2S-H High Sided (When heater is close to top bench)

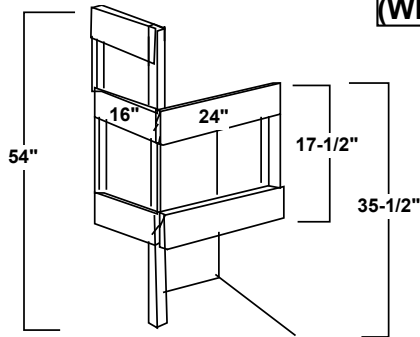

### HIGH SIDE HEATER GUARD FENCE

- 1 @ 18" 2X2
- 1 @ 36" 2X2
- 1 @ 54" 2X2
- 1 @ 24" 1X3

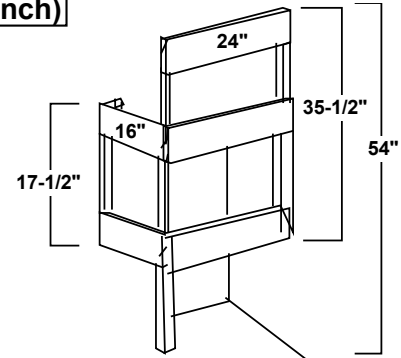

## 3S-H High Sided (When heater is close to top bench)

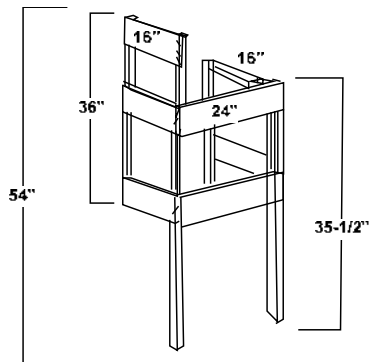

- 1 @ 18" 2X2
- 2 @ 36" 2X2
- 1 @ 54" 2X2
- 7 @ 24" 1X3

## FLOOR STANDING

- ### 2S-FM
- 3 @ 36" 2X4 posts
  - 4 @ 36" 1X4 s4s

- ### 3S-FM
- 4 @ 36" 2X4 posts
  - 6 @ 36" 1X4 s4s

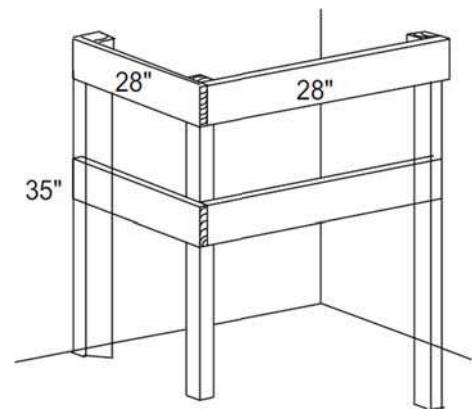

### 2 & 3 sided



### High sided



### 3 sided for floor standing heater



**OPTIONAL**  
**1" x 4" DUCKBOARD FLOOR-(WALKING AREA ONLY)**

1x4 cedar tops  
- 1/2" to 5/8" spacing

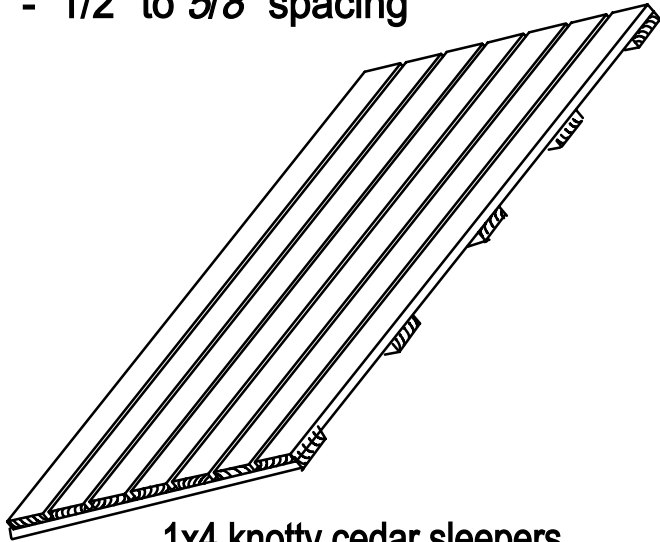

1x4 knotty cedar sleepers  
- 12" O.C.



**OPTIONAL CEDAR WINDOW TRIM**  
**(where required)**

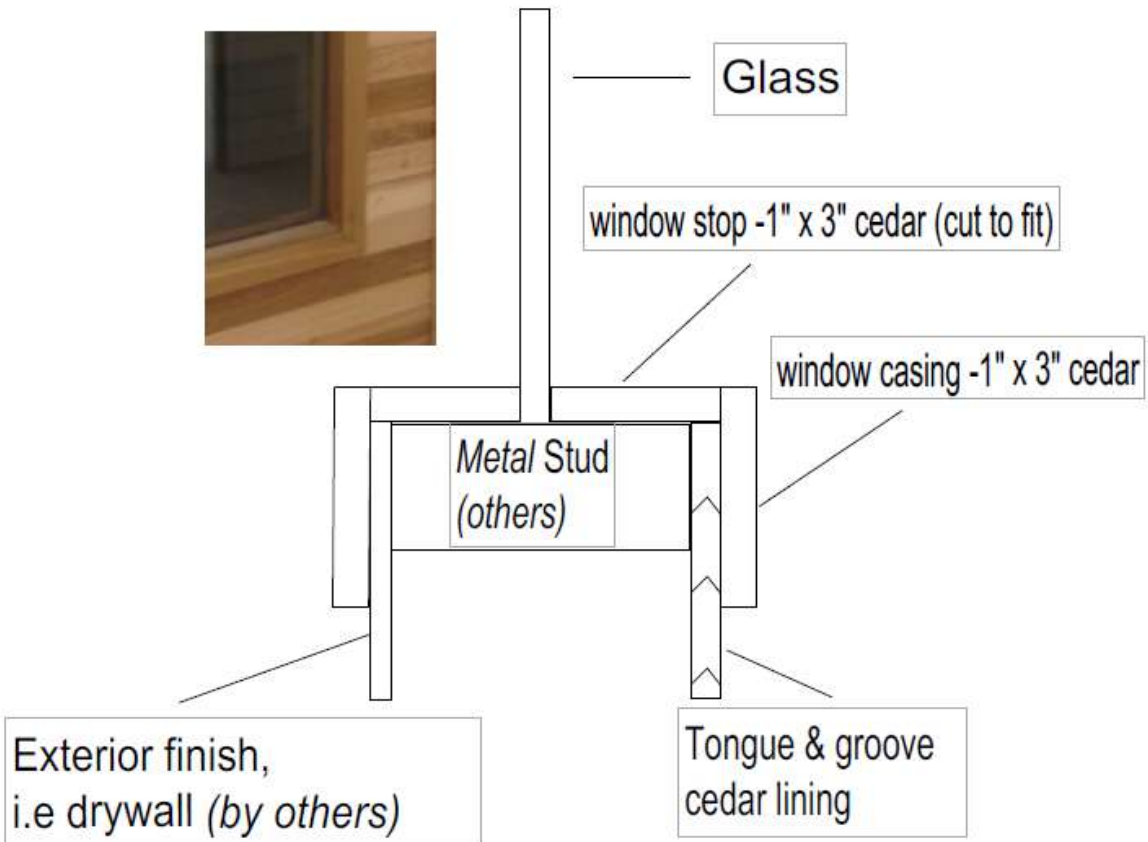

# Residential Saunas

# RESIDENTIAL SAUNA SECTION

Sauna Side View, Residential, Tile Base

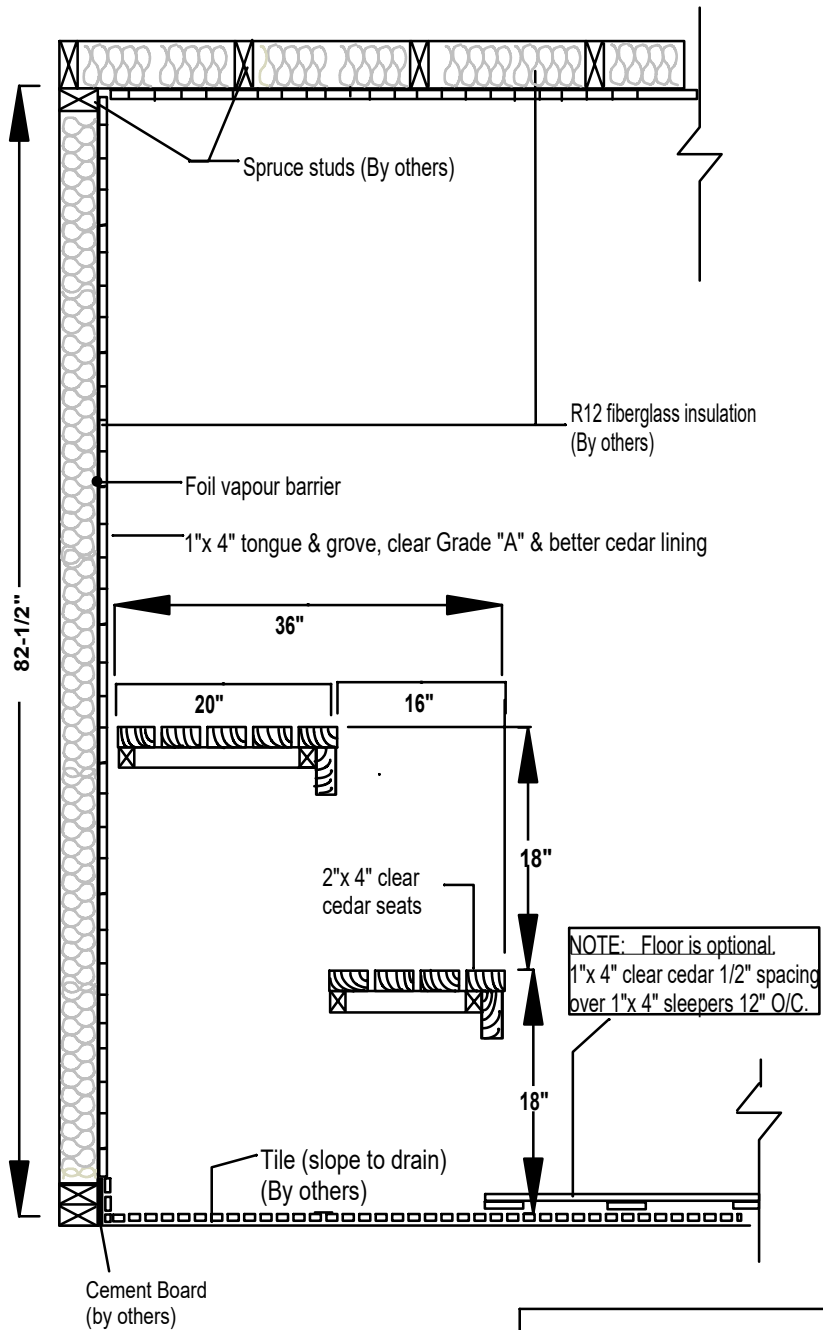

**Not To Scale**

# RESIDENTIAL TOP VIEW

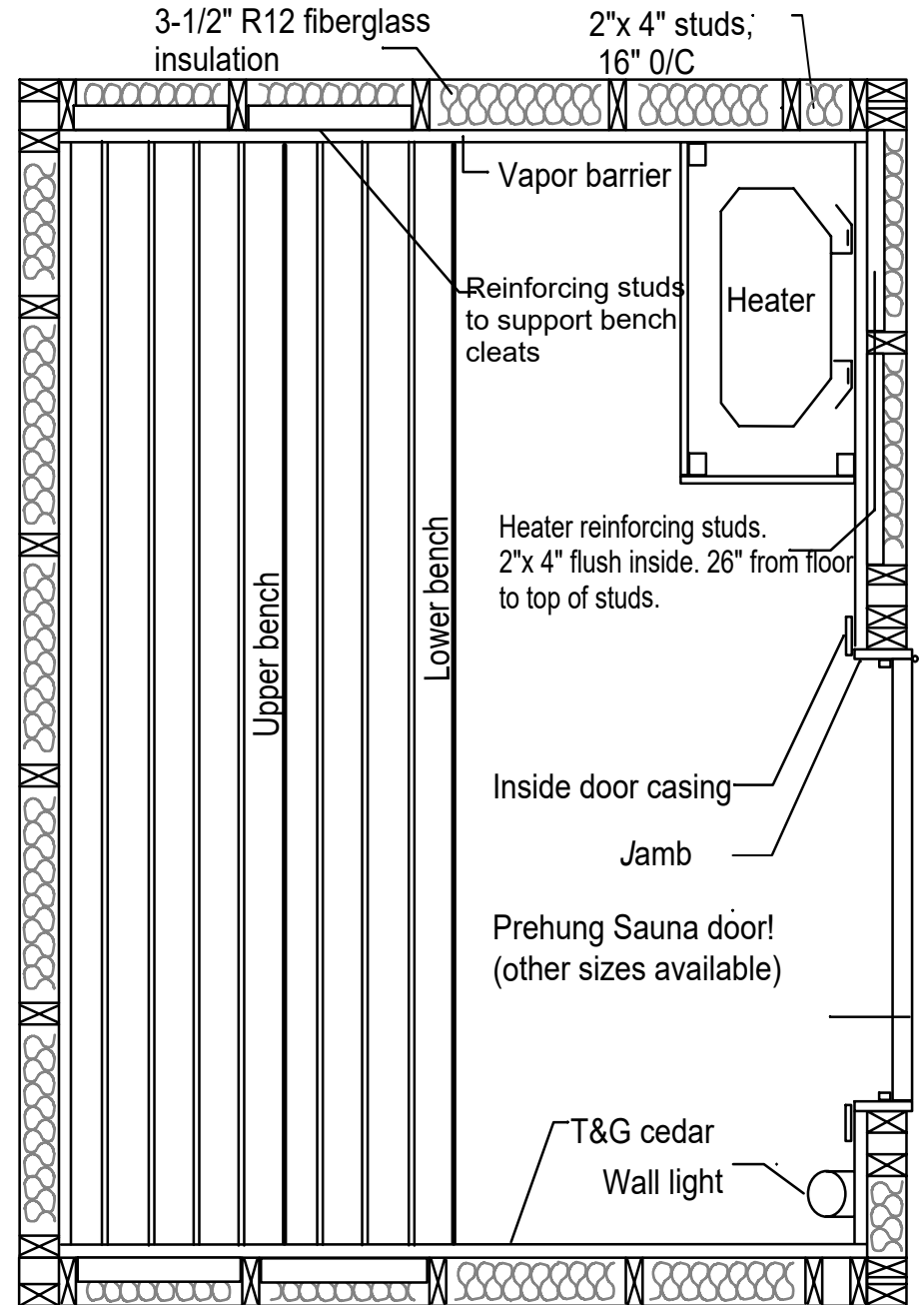

Reinforcing studs are imperative.  
Add reinforcing stud on adjoining wall for corner mounted heater.

# SAUNA DOORS

**NOTE:** Rough Opening means above "finished" floor; i.e. above tile

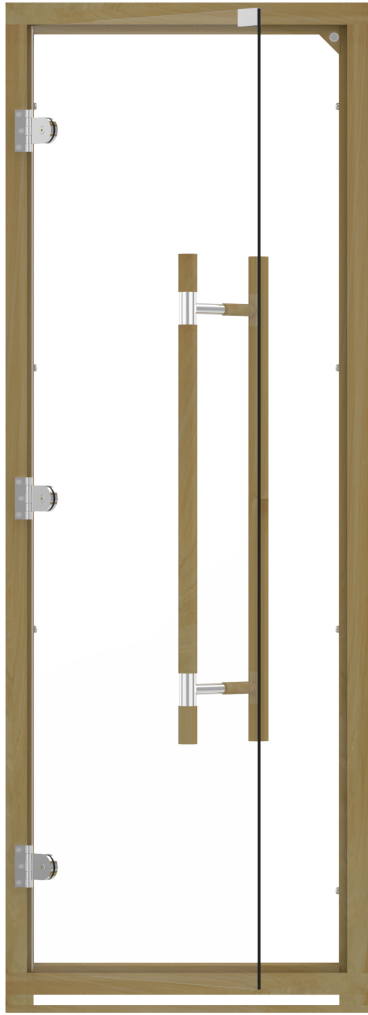

## Frameless

R/O=27-1/2" x 76-1/2"  
incl bottom spacer with gap

(Hinge is reversible)



## Cedar Framed Insulated Glass

R/O=26" x 76-1/2" gap under door (non-reversible)

NOTE: Gap or spacer can be deleted if you have effective cross ventilation as detailed in manual



### Trim/Double Header

If you don't use frameless door bottom spacer, or door is shorter than R/O for another reason, you can "double case" header



### Tips

If you don't want to see screws on jamb, you can screw behind stops

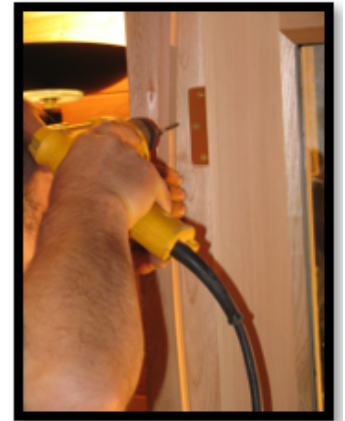

After installing door, replace center screw on each hinge with longer screws provided with kit



**NOTE:** We do provide instructions for how to hang a door. That is not something unique to saunas. We assume installer is familiar with how to shim, square and secure a door in place. If not there are numerous YouTube video demonstrations.



## STANDARD RESIDENTIAL GLASS SAUNA DOOR - CLEAR

Glass Options: Obscure, Plain Sandblast, Bronze Reflective & Designer Sandblast

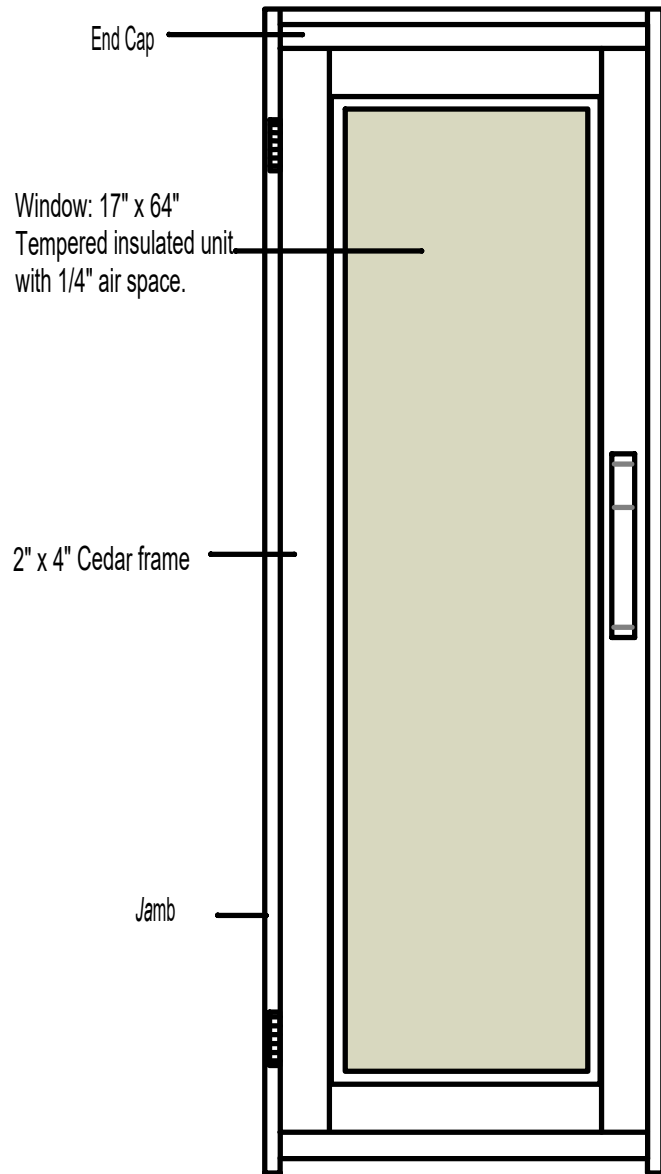

**RESIDENTIAL ROUGH OPENING**  
Standard R/O = 26" x 76"

**Standard Door = 24" x 74"**

## SOLID CEDAR DOOR (PRE-HUNG)

Optional

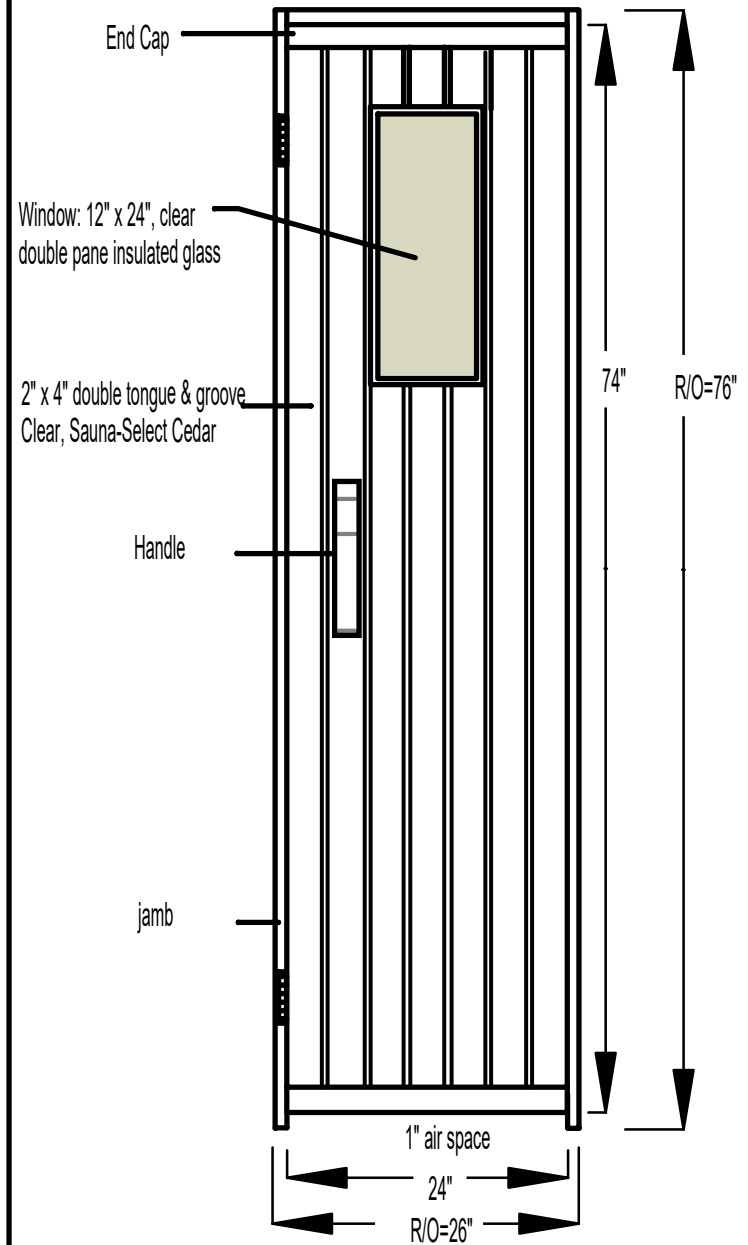

# DESIGNER BACKREST & SKIRT

## Bench Skirt (top riser)

1x2 s4s cedar tops (1x3 may be substituted).  
 1x4 x 12" s4s cedar sleepers  
 Assemble skirt from back, so nicer surface is facing front .  
 Nail using 1" nails with heads provided  
 Approx. 1/2" gap between bench tops for 12" height.  
 Sleepers approx. every 2'.  
 Install 2x2 cedar blocks to side wall at each end flush with bench floor support.  
 Secure skirt to centre bench support and end posts

Tip: Nailing skirt looks nicer. Screws are more visible  
 Screw if you want skirt to be removable

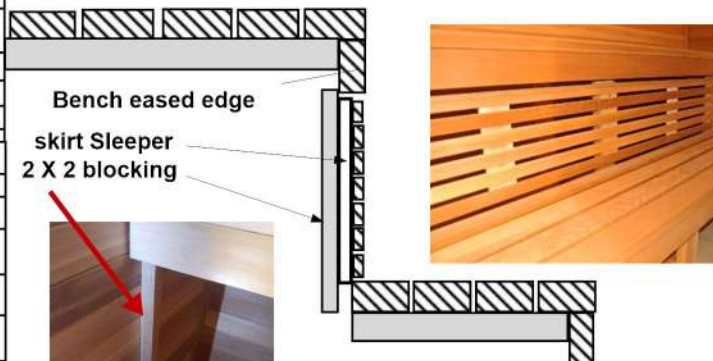
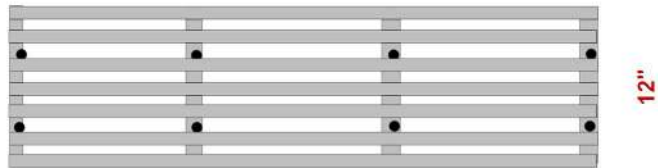

## DESIGNER BACKREST



Walls and backrest all from Clear cedar  
 Color variation is normal and expected with cedar



1x4 & 1x2 s4s cedar tops.  
 1x4 x 12" s4s cedar sleepers  
 Assemble backrest from back, so nicer surface is facing front .  
 Nail using 1" nails with heads provided  
 Approx. 5/8" gap between bench tops for 12" height.  
 Sleepers approx. every 2'.

Tip: Nailing backrest to wall looks nicer.  
 Screws are more visible

# Sauna Heaters



# HEATER SPECIFICATIONS

Watts	Room Size (cu. Ft.)		Min. Ceiling Ht.	Floor Size (Sq. Ft.)		Volts	Phase	Amps.	Wire Size*	Circuit Breaker*
	Min.	Max.		Min.	Max.					
<b><u>240 Volt Single Phase</u></b>										
<b>Wall Mounted</b>										
4000	100	150	78"	12	30	240	1	16.7	10	30
5000	150	250	78"	18	38	240	1	20.8	10	30
6000	200	300	78"	25	46	240	1	25	8	40
7500	290	375	78"	36	57	240	1	31.3	8	40
9000	360	450	78"	45	69	240	1	37.5	8	50
<b>Floor Standing</b>										
12000	450	700	84"	56	93	240	1	50	6	60
15000	600	900	84"	75	114	240	1	62.5	4	80
<b><u>208 Volt Single &amp; Three Phase</u></b>										
<b>Wall Mounted</b>										
5000	150	250	78"	18	38	208	1	24	10	30
6000	200	300	78"	25	46	208	1	28.9	8	40
6000	200	300	78"	25	46	208	3	16.6	10	30
7500	290	375	78"	36	57	208	1	36	8	50
7500	290	375	78"	36	57	208	3	20.9	10	30
9000	360	450	78"	45	69	208	1	43.2	6	60
9000	360	450	78"	45	69	208	3	25	8	40
<b>Floor Standing</b>										
12000	450	700	84"	56	93	208	1	57.7	4	70
12000	450	700	84"	56	93	208	3	33.4	8	50
15000	600	900	84"	75	114	208	3	41.7	6	60
18000	750	1050	84"	100	143	208	3	50.3	6	70

**\* Wire and Breaker size is recommendation only. Confirm with your licensed electrician.**

**Sauna Sizing:**

Sauna heat is stratified. Recommend height is 7'. Max. height should never be higher than 8'. Try not to press maximum range of heater. Recommend targeting 90% of capacity

**240v/1phase:** Standard Residential power in USA & Canada is 240 volt, 1 phase.

**208 volt, single phase:** May be found in some commercial construction and certain high apartment density cities (i.e., Manhattan)

**208volt/3phase:** Commonly used in commercial construction; i.e., condos, hotels, clubs, etc.

# SAUNA CRAFT CW SERIES HEATER DETAIL

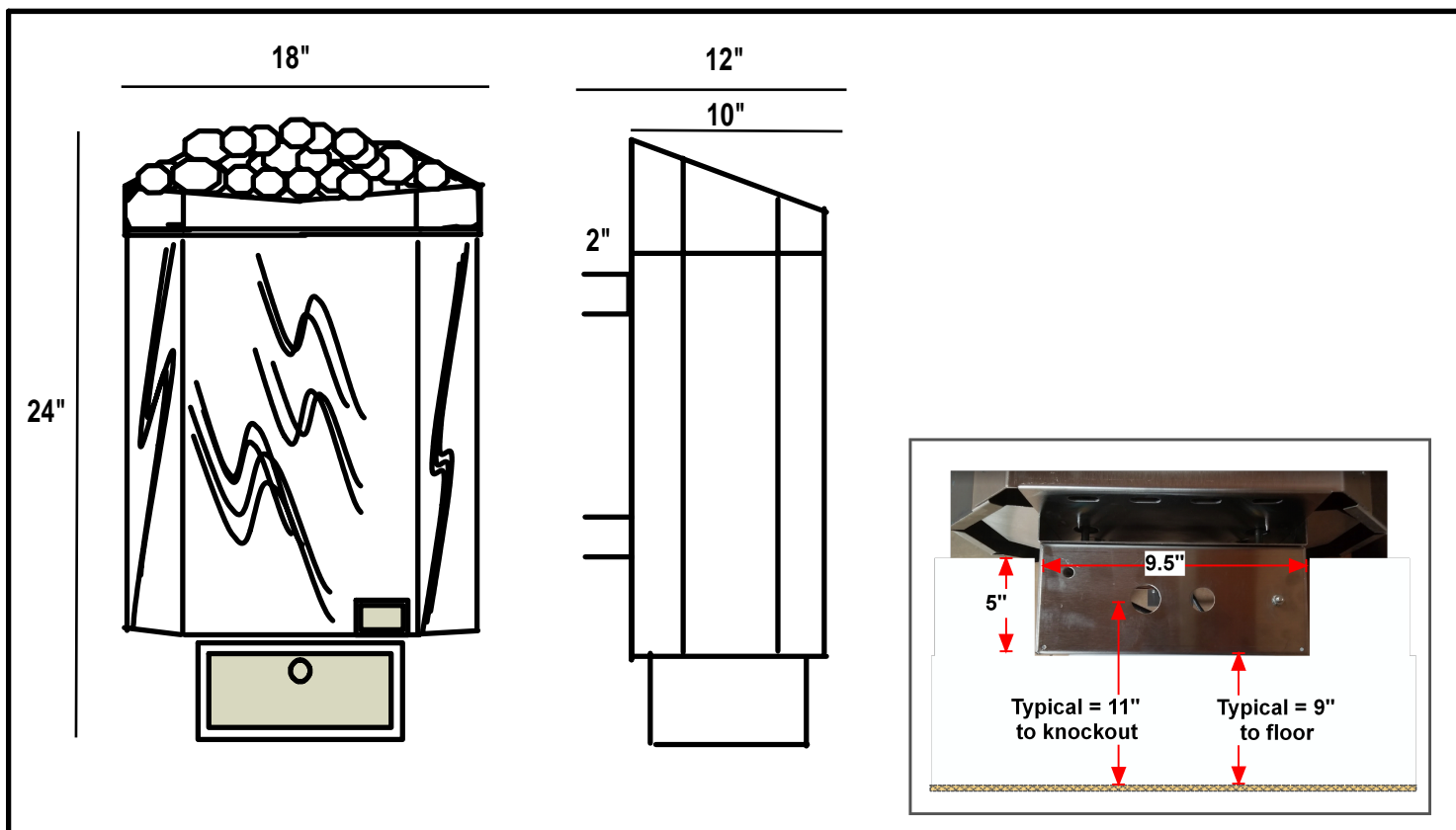

## CEILING

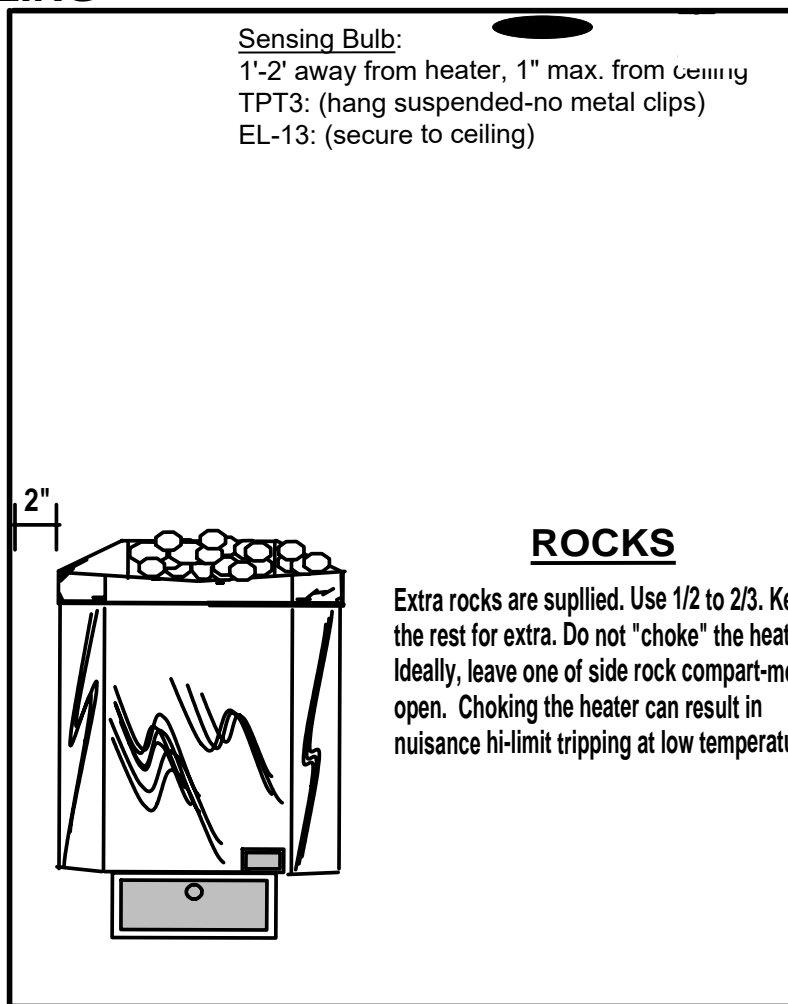
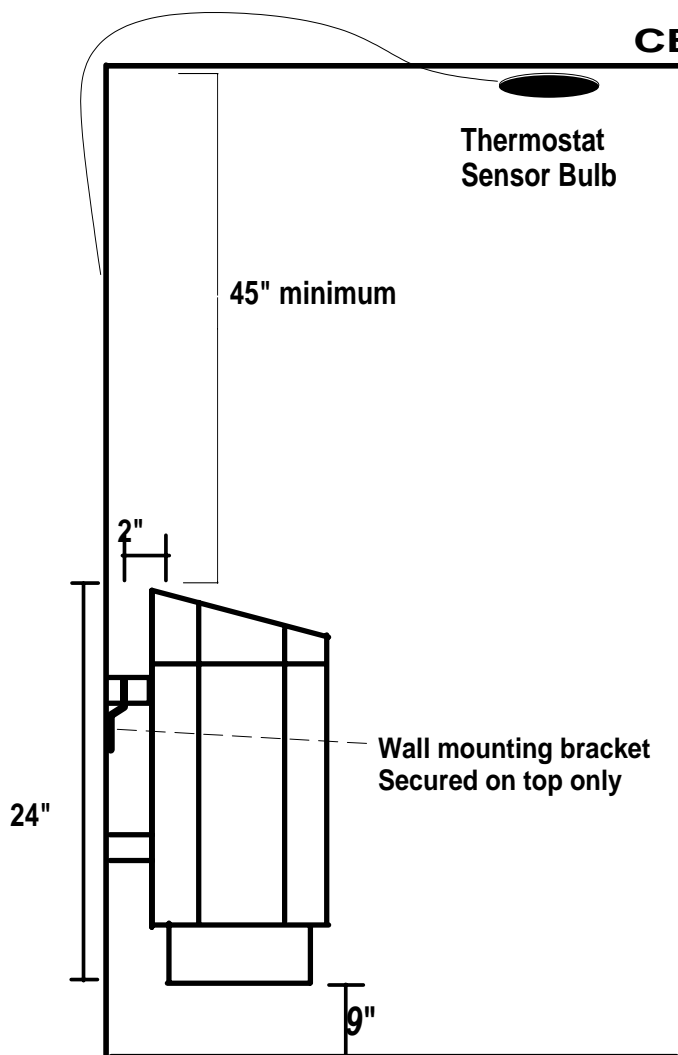

# SAUNA CRAFT FM SERIES HEATER DETAIL

## FM SERIES HEATER (12 - 18 kw)

**SAUNA CRAFT "FM"** heaters are floor standing heaters. The heater must be installed at least 4" from all adjacent surfaces (e.g. walls, guard fence, ect..) and the minimum ceiling height must be 84".

The controls are located on the outside wall of the sauna, preferably beside the door. Only the sensor bulb is located inside the sauna and is to be mounted 1' to 2' from the heater, at the ceiling.

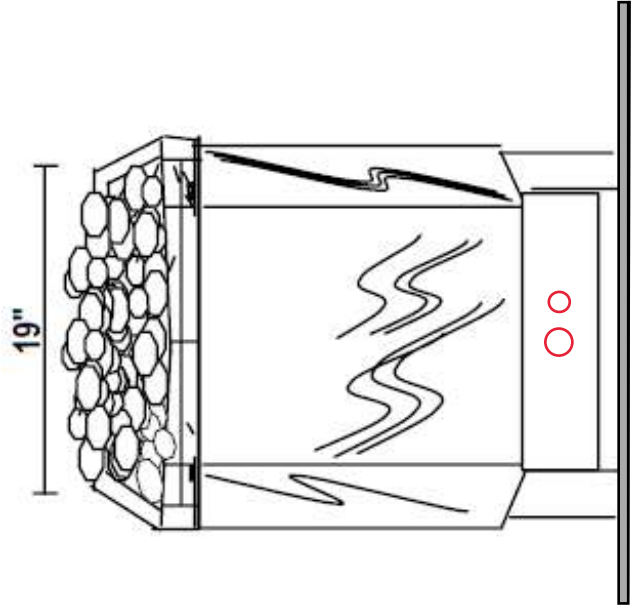
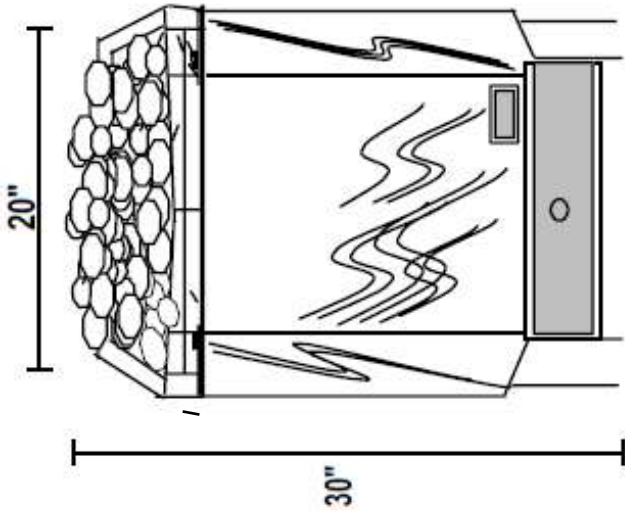

Floor to knock-out = 4"

### CEILING

Sensing Bulb:  
1'-2' away from heater, 1" max. from ceiling  
TPT3: (hang suspended-no metal clips)  
EL-13: (secure to ceiling)

45" minimum

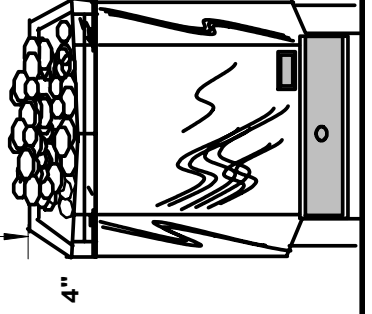

### ROCKS

Do not "choke" the heater. Stack rocks in a loose pyramid style, leaving pockets of air. You should be able to glimpse the elements hear and there. Choking the heater will result in nuisance hi-limit tripping at low temperatures.

# SAUNA *Craft*

# SAUNA HEATERS

- Precisely engineered baffled construction provides enhanced air flow for quicker heat-up time and cost saving efficiency.
- CW Series sauna heaters can be mounted on a straight wall or in a corner. FM Series are floor mounted.
- Premium #304 stainless steel dual shielding shell design.
- Rugged construction for years of safe, low cost, efficient sauna enjoyment.
- Highest quality, low watt density heating elements.
- Expanded Mesh Rock Tray protects heating element while providing maximum air flow.
- Built-in high temperature safety cut-off.
- Safety certified .

MODEL SUFFIX #	Kw	VOLTS PHASE	AMPS BREAKER	WIRE	CUBIC FEET	
					MIN.	MAX.
Standard Household is 240 V, single phase						
431	4	240 / 1	17 / 30	10	100	150
531	5	240 / 1	21 / 30	10	150	250
631	6	240 / 1	25 / 30	10	200	300
731	7.5	240 / 1	31 / 40	8	290	375
931	9	240 / 1	37 / 50	8	360	450
1231	12	240 / 1	50 / 60	6	450	650
1531	15	240 / 1	63 / 80	4	600	800
Commercial Voltage is usually 208 V, three phase (single phase available)						
623	6	208 / 3	17 / 30	10	200	300
723	7.5	208 / 3	21 / 30	10	290	375
923	9	208 / 3	25 / 40	8	360	450
1223	12	208 / 3	33 / 50	8	450	700
1523	15	208 / 3	42 / 60	6	600	900
1823	18	208 / 3	50 / 70	6	750	1050

**Breaker/wire size is recommendation only. Confirm with your licensed electrician.**

## "CW" Series - 4 kw to 9kw (Wall Mounted)

## "FM" Series - 12 kw to 18 kw (Floor Standing)



### CWS/CWM MODEL

100% Stainless Steel shell, baffles, frame and rock tray. Premium grade Stainless Steel will not rust.  
Size: 12" x 18" x 24"

FIVE YEAR RESIDENTIAL LIMITED WARRANTY.  
ONE YEAR COMMERCIAL LIMITED WARRANTY.



### CW-XR MODEL

100% Stainless Steel shell, baffles, frame and rock tray. Premium grade Stainless Steel won't rust. "Euro-Style" with deep mesh rock tray, providing a larger, vertical column of rocks for more effective vaporization of water. Ultra low watt density elements.  
Size: 12" x 18" x 24"

LIFETIME RESIDENTIAL LIMITED WARRANTY  
THREE YEAR COMMERCIAL LIMITED WARRANTY



### FM MODEL

Stainless Steel shell & baffles and Stainless frame and rock tray.  
Size: 20" x 20" x 30"

FIVE YEAR RESIDENTIAL LIMITED WARRANTY.  
ONE YEAR COMMERCIAL LIMITED WARRANTY.



### FM-XR MODEL

100% Stainless Steel shell, baffles, frame and rock tray. Premium grade Stainless Steel won't rust. "Euro-Style" with deep mesh rock tray, providing a larger, vertical column of rocks for more effective vaporization of water. Ultra low watt density elements.  
Size: 20" x 20" x 30"

LIFETIME RESIDENTIAL LIMITED WARRANTY  
THREE YEAR COMMERCIAL LIMITED WARRANTY

## Sauna controls

### TPT3 Control



(Standard)  
Thermostat, spring timer & pilot light

### Electronic Control



(Optional)  
Quiet operation  
No ticking noise

# **FSA421 COMMERCIAL SAUNA CONTROL** **(for Sauna Craft Heaters)**

Stand-Alone electronic control pre-set to sauna operation parameters.  
Control can be installed near sauna or remotely in equipment room.  
Control can be locked so that settings can not be altered.

One hour spring timer for public access.







# Tylo Residential SAUNA HEATERS

*The heart of every sauna is the sauna heater. TYLO sauna heaters are widely renowned and greatly respected for their high quality and distinct features - but not everyone knows all the reasons for this. That's why we'd like to take the opportunity to point out some of the most important benefits of the TYLO design and why the hottest range of sauna heaters on the market knocks all the others cold.*

## **Quickest heat-up time.**

Twin side chambers maximize the through-flow of air, minimize heat-up time and economize on running costs. No other sauna heater uses less energy.

## **The lowest energy consumption.**

Test after test confirms that TYLO is the most energy-efficient sauna heater.

## **The most even bathing temperature.**

A divided output is the secret behind the constant bathing temperature and lower energy consumption of a TYLO heater. Divided output means the heater elements cycle in stages. For the initial heat up all the elements are on, then the elements cycle on and off in stages as needed to maintain an even temperature. Other heaters are either 100% on or completely off, resulting in a temperature swing. TYLO heaters maintain an overall higher and more consistent temperature.

## **The finest material quality.**

Only TYLO has a solid-cast top, inner casing and stainless steel stone compartment.

## **Optimum water sprinkling.**

A deep generously proportioned stone compartment, and direct contact between the stones and the heating elements ensure perfect water sprinkling with 100% vaporization.

## **Built-in humidifier.**

This unique TYLO feature further enhances your sauna bathing experiences.

## **Safe to touch.**

Thermosafe soft touch covering ensures a low surface temperature - just 40°C on the front and sides of the heater.

## **Best in test.**

Time and time again TYLO has scored top marks in Finnish sauna tests. TYLO was first awarded the coveted "Best in Test" accolade in competition with seven Finnish heaters in 1982. A test published in a Finnish magazine (Kuluttaja no.5, 1995) confirmed that TYLO also has the quickest heating-up time and lowest energy consumption. A SEMKO test in April 1999 confirmed this result, and also proved that the steam generating performance of TYLO heaters was unrivaled.





**SenseSport**  
(control at bottom of heater)

Control panel with thermostat and mechanical timer integrated into the base of the heater



The Sense models are a brand new sauna heater, combining sleek design with the reliable functionality and genuine quality of TYLO. Removable compartment for fragrant essences



**TYLO SENSE PLUS with PURE 2.0 or ELITE control**

The TYLO SENSE PLUS uses the separate control mounted outside the sauna or inside at less the 3' above floor level.

**PLUS Control**

**Elite Wi-Fi Control**



**TYLO SENSE COMBI w/ PURE or ELITE**

The TYLO COMBI is quite simply the most sophisticated sauna heater on the market-the only heater that lets you enjoy traditional saunas and steam or herbal saunas (Tylarium) in one and the same room. The choice is yours-a traditional sauna at 68-90°C (155-194°F) in a relative humidity of 5-35%, or a steam sauna at 45-65°C (110-150°F) with steam at 40-65% humidity. You can even add a little spice to your bathing with a refreshing herbal sauna. The heater has built-in dispensers for dried or fresh natural herbs and liquid essences, so you can blend your own favorite fragrance.

The COMBI has all the hallmark features of a quality TYLO heater, plus a number of special technical innovations: electronic programming of bathing mode (time, temperature and humidity), stainless steel water reservoir, 10 hour pre-set function and a 1 hour bathing time. Automatic and manual on/off, electronic low-water cut-off; and automatic drying function after completion of steam sauna cycle.

Residential Models	KW	VOLTS	PHASE	AMPS	*BREAKER	*WIRE	CUBIC FEET	
							MIN.	MAX.
5	4.7	240	1	18.3	30	10	70	210
7	7	240	1	29.2	40	8	140	320
8	8.3	240	1	34.6	40	8	175	440

\*Breaker & wire size is recommendation only. Confirm with your licensed electrician.



Tel 905-738-4017 Toll Free 1-800-387-7029  
 Fax 905-738-2486  
 www.saunafin.com

# TyloHelo Pro Model Commercial Sauna Heater



Freestanding Pro heaters have been the standard of the industry for more than 20 years. Designed for large, commercial-sized sauna rooms and for use with separate control panels.

Stainless steel construction. Contactor box required.

Links:

[Pro Heater with Elite/Pure Control Manual](#)

<b>PRO</b>	<b>PRO 105</b>	<b>PRO 120</b>	<b>PRO 140</b>
Sauna size (cu. ft.)	390-600	510-740	630-950
Heating power (kW)	10.5	12.0	14.4
Vulcanite rocks (lbs)	132	132	132
Dim. (inch) (W x H x D)	20 x 29 x 19	20 x 29 x 19	20 x 29 x 19
Control unit	Elite, Pure 2.0,	Elite, Pure 2.0,	Elite, Pure 2.0,

# Optional External Switch for Tylo Pro Heaters

## **Overview:**

**This momentary, illuminated switch provides simple ON/OFF function to your Tylo Plus or Combi heater. This optional external switch will provide the sauna bather with the ability to turn the sauna ON or OFF only.**

**When the momentary switch is activated, the power icon will illuminate in blue and activate the sauna session that has been programmed into the main control. Pressing the switch when it is illuminated will remove power to the sauna heater and end the bathing session.**

