

IS-IR SAUNA ROUGH-IN-

#####

Infrared saunas are much more time consuming to install as compared to traditional saunas. Each emitter needs to be wired individually and spaced according to room size and bench configuration. Wiring is often done as sauna is being built.
 Please read through all manuals carefully, before starting.

Wall emitters are mounted vertically. Size: 27" or 15" wide x 39" high
(For combination sauna, there must be 5" of clearance above the traditional sauna heater and the bottom of any IR frame.

**Infrared: IR ##,
 # kw, 240v**

**Traditional: DSNR #
 # kw, 240v**

**Infrared:
 IR ###,
 ## kw, 240v**

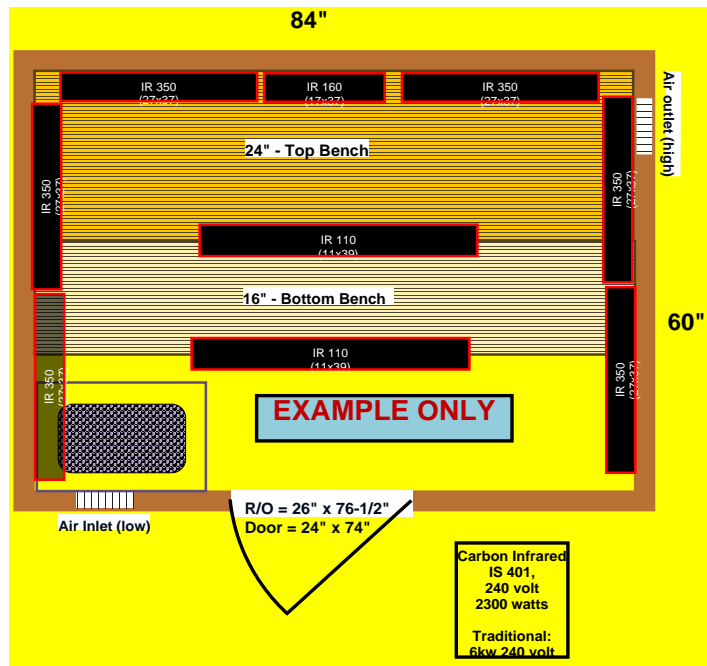

**** SUPPLY WIRE/BREAKER (not Included)**

CB box to be installed under bench (or elsewhere close to sauna.)

amp, 240-volt breaker (Non GFI)

##/2 from panel to CB box

##/2 from CB box to traditional heater.

14/2 wire for IR emitters. From CB box to nearest emitter. Then daisy chain to all other emitters.

NOTE: If trying to maintain low EMF, use BX armored cable rather than Romex.

**** Note: Wire gauge and breaker based on higher amperage, which applies when traditional heater added. If you are installing Infrared heaters only, your electrician may size wire and breaker accordingly.**

INSTRUCTIONS

- Shop Drawing Rough In: **See below**
- Infrared Heater Panels Installation Manual: <https://www.saunafin.com/uploads/documents/051e74948a7c272da4acd886fedbdc24235bba0f.pdf>
- Infrared Panels Supplemental Installation: <https://www.saunafin.com/uploads/documents/920152ab9da2ce7c76ae52ad2ed5b5adae9c0f11.pdf>
- Cedar Material Installation (Infrared): <https://www.saunafin.com/uploads/documents/2b723a991c52792aeb1e6d27d0beb2cc703e5b31.pdf>

CONTROL

Install outside sauna

Connect low voltage cable from the SaunaLogic SL2 IS control to CN1 of the circuit board in the CB box.

SENSOR INSTALLATION

Locate top of sensor 2" from ceiling and directly above the IR-325-240 IR panel AND traditional sauna heater if installed. Feed the 17 ft "low voltage" sensor wire from the sensor location to the CB box location. Sensor wire must be routed completely separate (as per low voltage electrical wiring codes) from any wiring carrying over 50 volts. It may be necessary to drill holes to string the wire through the studs or ceiling joists.

Using a flat tip screwdriver, unsnap sensor cover from sensor. **Mount sensor to a finished wall directly above heater** and two (2) inches down from ceiling using two (2) screws (provided)

Connect sensor cable to CN4 of the circuit board in the CB box.

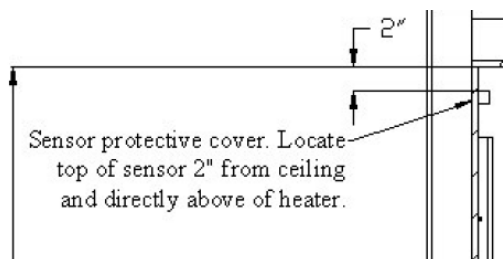

ACCENT LIGHT PACKAGE (OPTIONAL)

The lighting package consists of 3 color therapy lights, , and the cables to connect the light assemblies to the CB box.

Connect the color therapy light cable to Color Lamp of the circuit board in the CB box.

Light Fixture Installation: Cut 2 3/4" holes in tongue and groove boards for light fixtures. Ensure the lighting cables reach the hole locations

TRADITIONAL SAUNA HEATER WIRING TRADITIONAL SAUNA HEATER (If ordered).

Install wire from the CB box to the location of the bottom of the sauna heater.

A two-conductor cable is provided with the sauna heater for the high limit safety switch. Pre install wire in the wall. The traditional sauna system will not work if the wires and switch are not connected.

Note: Run supply wire from CB panel to traditional heater - approx. 1' above floor.

IR EMITTER INSTALLATION

Emitters come with 54" wire whip. Drill hole for whip. Feed whip or guide string from hole to one gang box mounted close to floor as shown in installation guide.

Each IR emitter to be connected to an electrical junction box. All IR emitters should be grounded.

Use 14-2 AWG wire w/ground from the CB box to closest IR emitter. Daisy chain the wire from the first IR emitter to box for next and continue for each IR emitter connection.

Note: If trying to maintain low EMF, use BX armored cable rather than Romex.

IR assembly can be installed above the traditional sauna heater. There has to be 5" of clearance above the traditional sauna heater and the bottom of the IR assembly. See Diagram 1 for specific spacing requirements.

Surface Mounted IR Heating Assembly Information

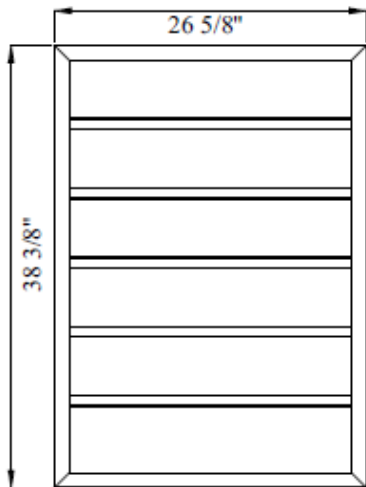

IR-325-240-S

Quantity: #

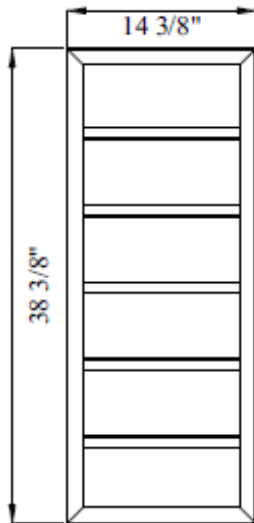

IR-160-240-S

Quantity: #

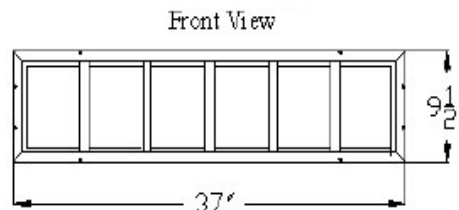

Quantity: # (bench riser)



Back view of whip

Rough In Emitter Wire

There is a 54" whip centered one emitter has, 1-1/2" from bottom edge.

Walls: Rough in hole for wire whip at 38-1/2" above finished floor (aff) (based top 36" top bench)

Over optional Viki traditional heater: Requires 5" Clearance above heater. Rough in for wire at 41" aff

Bench riser (1 or 2): Locate one-gang electrical box, so that whip at one end will reach.

**** Note: Wire gauge and breaker based on higher amperage, which applies when traditional heater. If you are installing Infrared heaters only, your electrician may size wire and breaker accordingly.**

DIAGRAM 2

MODEL	IR kW	Sauna kW	* Optional Traditional Heater	MINIMUM ROOM			MAXIMUM ROOM			PHASE	VAC	IR AMPS	WIRE SIZE		
				Floor Area	Ceiling Height	Volume Cu.Ft.	Ceiling Height	Volume Cu.Ft.	Power Supply to CB PK-5				CB PK-5 to IR Heating Panels	CB PK-5 to Traditional Heater	
IS-201/202	1.6	3.0	Junior 3.0	12 sq. ft.	73 1/2"	100	96"	150	1	240	6.5	2 #12AWG+GR	2 #14AWG+GR	2 #12AWG+GR	
IS-301/302	2.0	4.5	Viki 4.5	16 sq. ft.	73 1/2"	135	96"	200	1	240	8.3	2 #10AWG+GR	2 #14AWG+GR	2 #10AWG+GR	
IS-401/402	2.3	6.0	Viki 6.0	21 sq. ft.	73 1/2"	175	96"	300	1	240	9.6	2 #10AWG+GR	2 #14AWG+GR	2 #10AWG+GR	
IS-601/602	3.0	8.0	Viki 8.0	31 sq. ft.	73 1/2"	250	96"	425	1	240	12.3	2 #8AWG+GR	2 #14AWG+GR	2 #8AWG+GR	

* Denotes an optional traditional sauna heater may be added to the system. Refer to Installation and Operation manual for installation questions.

All installation and service to this equipment should be performed by qualified licensed personnel in accordance with local and national codes.

IR Heating Panel Quantities			
MODEL	IR-325-240	IR-160-240	IR-110-240
IS-201	4	1	1
IS-301	5	1	2
IS-401	6	1	2
IS-601	8	1	2

IR Heating Panel Quantities			
MODEL	IR-325-240	IR-160-240	IR-110-240
IS-202	3	3	1
IS-302	4	3	2
IS-402	5	3	2
IS-602	7	3	2

ROOM ROUGH IN FOR SURFACE MOUNT IR EMITTERS:

Build the frame the room with standard building materials and framing design.

Install single gang outlets below the IR Emitters. Rough in all lighting wires, IR emitters wires, Sensor wire, Control wires before insulating the room and applying foil vapor barrier.

Tongue and groove the ceiling. While installing the tongue and groove on the ceiling continue to cut in the light holes and install and connect the lights as the ceiling is installed. Access will be difficult after ceiling is completed.

Apply tongue and groove wood on the walls (vertical or horizontal depending desires installation). Cut wood around the electrical access boxes. Cut an electrical access behind the IR Emitter to feed the wire from the emitter into the electrical box. (Pictures do not show the cut out behind IR emitter.)

Remove the cover from Surface Mount IR Emitter by holding the wire on the back of emitter and pull the cover away to the front. It will release a mechanical lock. Install the wire from the IR emitter into the wall and into the electrical box below. Install the extra wire in the wall and then attach IR emitter panel to the wood wall with 6 screws (3 on each side).

Reinstall the cover by placing the top of cover over the IR panel and pull down. It will catch two notches at the top of the wall and then push the lower part of the cover against the IR panel and the cover will “click” into place. The cover will be flush all the way around the IR emitter for clean finished look.

Splice in the electrical panels into the electrical box and cover with metal single gang blank plate.

Continue this process to complete the room.



DIAGRAM 3

Typical IS Installation with a Traditional Sauna Heater

Refer to Diagram 1 and 2 for minimum spacing requirements depending on the traditional sauna heater.

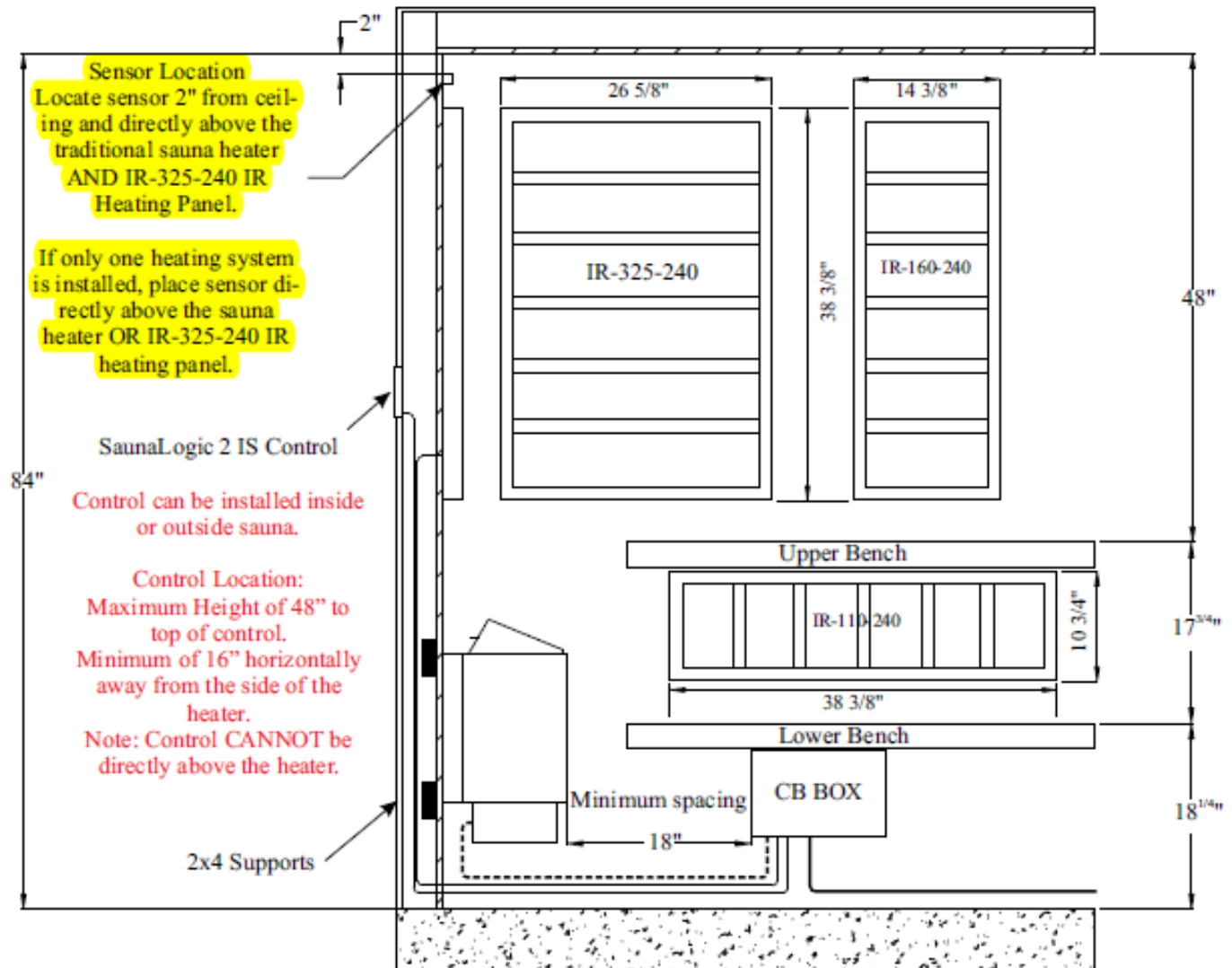

CB Box can be outside of the sauna room or installed inside sauna room.

DIAGRAM 4

DIAGRAM 5

SL2 IS Control

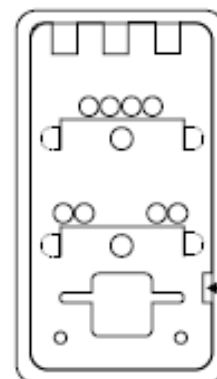
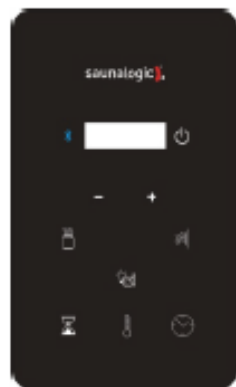

Back of sensor

Insert screwdriver tip here to unsnap sensor cover from sensor. Note vertical orientation of cover before removing.

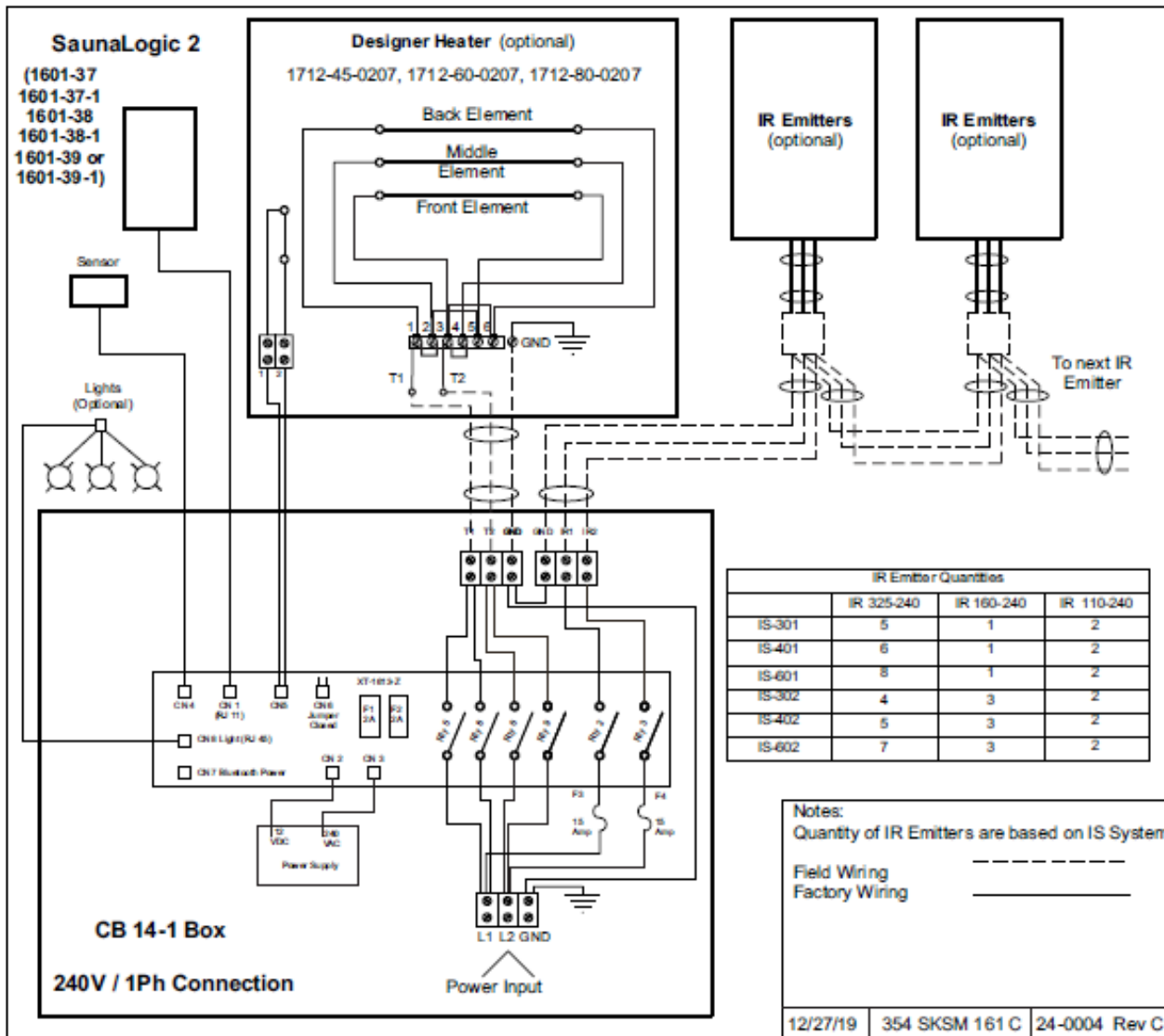

DIAGRAM 7 CB 14-1 BOX

