

SAUNA HEATERS

- Precisely engineered baffled construction provides enhanced air flow for quicker heat-up time and cost saving efficiency.
- CW Series sauna heaters can be mounted on a straight wall or in a corner. FM Series are floor mounted.
- Premium #304 stainless steel dual shielding shell design.
- Rugged construction for years of safe, low cost, efficient sauna enjoyment.
- Highest quality, low watt density heating elements.
- Expanded Mesh Rock Tray protects heating element while providing maximum air flow.
- Built-in high temperature safety cut-off.
- Safety certified .

MODEL SUFIX #	Kw	VOLTS PHASE	AMPS BREAKER	WIRE	CUBIC FEET	
					MIN.	MAX.
Standard Household is 240 V, single phase						
431	4	240 / 1	17 / 30	10	100	150
531	5	240 / 1	21 / 30	10	150	250
631	6	240 / 1	25 / 30	10	200	300
731	7.5	240 / 1	31 / 40	8	290	375
931	9	240 / 1	37 / 50	8	360	450
1231	12	240 / 1	50 / 60	6	450	650
1531	15	240 / 1	63 / 80	4	600	800
Commercial Voltage is usually 208 V, three phase (single phase available)						
623	6	208 / 3	17 / 30	10	200	300
723	7.5	208 / 3	21 / 30	10	290	375
923	9	208 / 3	25 / 40	8	360	450
1223	12	208 / 3	33 / 50	8	450	700
1523	15	208 / 3	42 / 60	6	600	900
1823	18	208 / 3	50 / 70	6	750	1050

Breaker/wire size is recommendation only.
Confirm with your licensed electrician.

"CW" Series - 4 kw to 9kw (Wall Mounted)

"FM" Series - 12 kw to 18 kw (Floor Standing)



CWS/CWM MODEL

100% Stainless Steel shell, baffles, frame and rock tray. Premium grade Stainless Steel will not rust.
Size: 12" x 18" x 24"

FIVE YEAR RESIDENTIAL LIMITED WARRANTY.
ONE YEAR COMMERCIAL LIMITED WARRANTY.



CW-XR MODEL

100% Stainless Steel shell, baffles, frame and rock tray. Premium grade Stainless Steel won't rust. "Euro-Style" with deep mesh rock tray, providing a larger, vertical column of rocks for more effective vaporization of water. Ultra low watt density elements.
Size: 12" x 18" x 24"

LIFETIME RESIDENTIAL LIMITED WARRANTY
THREE YEAR COMMERCIAL LIMITED WARRANTY



FM MODEL

Stainless Steel shell & baffles and Stainless frame and rock tray.
Size: 20" x 20" x 30"

FIVE YEAR RESIDENTIAL LIMITED WARRANTY.
ONE YEAR COMMERCIAL LIMITED WARRANTY.



FM-XR MODEL

100% Stainless Steel shell, baffles, frame and rock tray. Premium grade Stainless Steel won't rust. "Euro-Style" with deep mesh rock tray, providing a larger, vertical column of rocks for more effective vaporization of water. Ultra low watt density elements.
Size: 20" x 20" x 30"

LIFETIME RESIDENTIAL LIMITED WARRANTY
THREE YEAR COMMERCIAL LIMITED WARRANTY

Sauna controls

TPT3 Control



(Standard)
Thermostat, spring timer & pilot light

Electronic Control



(Optional)
Quiet operation
No ticking noise



Manufacturers & Distributors of:

- Sauna heaters
- Sauna Material Liner Kits
- Pre-Fab Saunas
- Infrared Saunas
- Steambath Generators

115 Bowes Rd, Unit 2,
Concord, ON. L4K 1H7
Ph:905-738-4017 / 800-387-7029
sales@saunafin.com
www.saunafin.com

STANDARD MODEL: CW-M (6-9kW) wall mounted / FM (12-18kw) floor standing

- 304 stainless steel shell and inner baffles.
- Stainless steel frame and rock tray.
- Element rod length is an industry leading 85" fully extended, which means the element has a lower watt density (it puts out full heat, but it will burn cooler).
- One year commercial warranty excluding elements.

DELUXE MODEL: CW-XRC(6-9kW) wall mounted / FM-XRC(12-18kw) floor standing

- XRC model is 100% constructed 304 stainless steel; including stainless steel frame & rock tray.
- DEEPER ROCK COMPARTMENT to bring rocks closer to heating elements.
- ULTRA LOW WATT DENSITY. Element rod length is an industry unmatched 130" fully extended, which means the element has burns much cooler making the element more resistant to damage from water and extended use.
- SILVER SOLDERED element bushings making them more resilient to water penetration.
- Extended THREE YEAR WARRANTY FOR COMMERCIAL USE, INCLUDING THE ELEMENT.

CONTROLS

TPT3

- Mechanical thermostat and 60-minute spring timer.
- Fits into 3-gang MBD electrical box (included).

EL-13

- Electronic push button control.
- Digital display of temperature and duration.
- Fits into 3-gang MBD electrical box (included).

EL-13-R (remote)

- Same as EL-13 above.
- Comes with additional on/off remote button.
- Control can be locked under cover or located in management area and control can be started and stop by customers. They have no access to control to change settings.

FSA421 COMMERCIAL CONTROL (Spring Timer)

- FSA421 Stand-Alone digital thermostat. Can be installed in equipment room or in access box. Often located with magnetic contactor.
- 60-minute spring timer.

FSA421 COMMERCIAL CONTROL (Push Button) (USA only)

- FSA421 Stand-Alone digital thermostat. Can be installed in equipment room or in access box. Often located with magnetic contactor.
- Push button industrial timer.
- Designed to avoid the problems associated with residential style spring timers and electronic controls.

Wall mounted "CW" models 4,000 watt to 9,000 watt



CW-M MODEL

100% Stainless Steel shell, baffles, frame and rock tray. Premium grade Stainless Steel will not rust.

Size: 12" x 18" x 24"

THREE YEAR RESIDENTIAL LIMITED WARRANTY.
ONE YEAR COMMERCIAL LIMITED WARRANTY.



CW-XRC MODEL

100% Stainless Steel shell, baffles, frame and rock tray. Premium grade Stainless Steel won't rust. "Euro-Style" with deep mesh rock tray, providing a larger, vertical column of rocks for more effective vaporization of water. Ultra low watt density elements.

Size: 12" x 18" x 24"

LIFETIME RESIDENTIAL LIMITED WARRANTY
THREE YEAR COMMERCIAL LIMITED WARRANTY

Floor standing "FM" models 12,000 watt to 18,000 watt



FM MODEL

100% Stainless Steel shell, baffles, frame and rock tray. Premium grade Stainless Steel will not rust.

Size: 20" x 20" x 30"

THREE YEAR RESIDENTIAL LIMITED WARRANTY.
ONE YEAR COMMERCIAL LIMITED WARRANTY.



FM-XR MODEL

100% Stainless Steel shell, baffles, frame and rock tray. Premium grade Stainless Steel won't rust. "Euro-Style" with deep mesh rock tray, providing a larger, vertical column of rocks for more effective vaporization of water.

Ultra low watt density elements.

Size: 20" x 20" x 30"

LIFETIME RESIDENTIAL LIMITED WARRANTY
THREE YEAR COMMERCIAL LIMITED WARRANTY

Standard Control

TPT3 Control



(Standard)
Thermostat, spring
timer & pilot light

EL-13 Electronic Control



(Optional)
Quiet operation
No ticking noise

Commercial Control

A421 w Spring timer



A421 w Push button



EL-13 R Control With separate On/off Button



SAUNA CRAFT CW SERIES HEATER DETAIL

CW SERIES HEATER (4 - 9 kw)

SAUNA CRAFT "CW" heaters can be installed on a straight wall or in a corner of the sauna room by means of TWO mounting brackets. The unit should be placed 6" (minimum) from the floor, 45" (minimum) from the ceiling and 2" (minimum) from vertical surfaces (walls) and the minimum ceiling height must be 78".

A non-metallic guard shall be provided and located not closer than 4" from the sauna heater.

Determine where the unit is to be located. Mark the locations for the top two angled brackets on the back of the unit. Fasten the mounting brackets using the 1-1/2" mounting screws (supplied). Be sure that the screws pass through the lining and into reinforcing studs in order to hold the weight of the unit (approx. 60lbs. with the rocks). Then simply hang the heater on the mounting brackets.

NOTE: THERE ARE ONLY TWO BRACKETS.

The controls are recessed into the outside wall of the sauna, preferably beside the door. Only the sensor bulb is located inside the sauna 1' to 2' from the heater 1" from the ceiling (see illustration).

ROUGH IN CONTROL BEFORE THE WALLS ARE CLOSED UP.

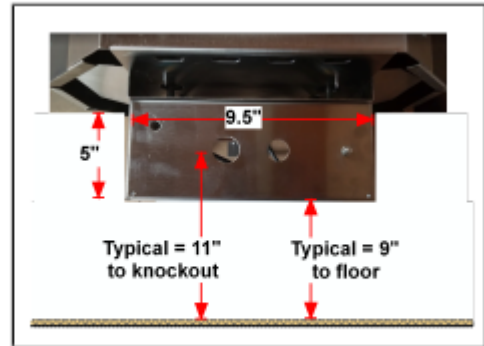
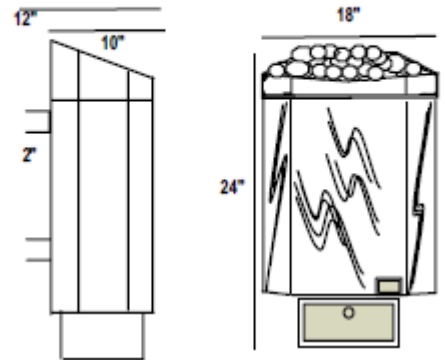

CEILING

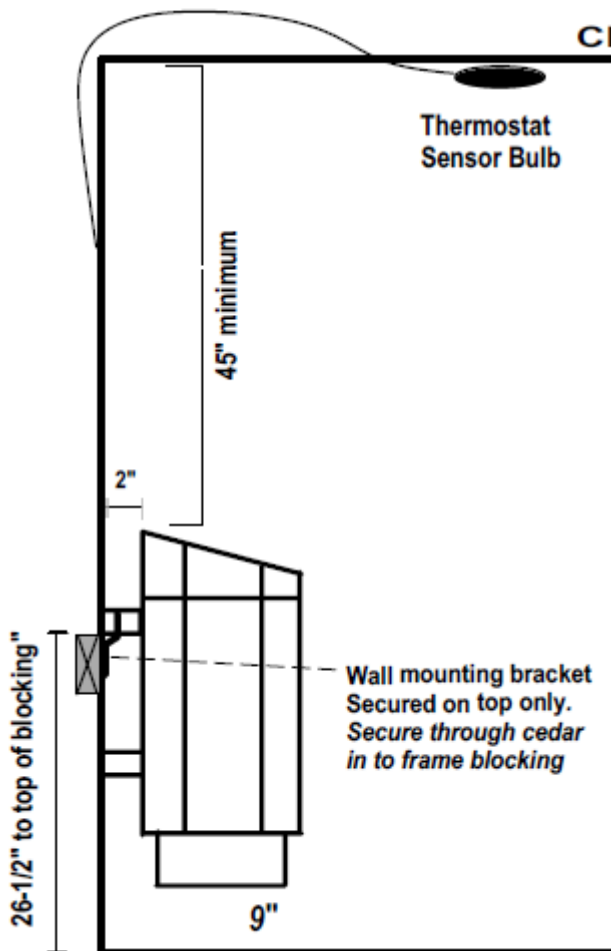

Sensing Bulb:

1'-2' max. away from heater, 1" max. from ceiling
TPT3: (hang suspended-no metal clips)
EL-13: (secure to ceiling)

ROCKS

Extra rocks are supplied. Use 1/2 to 2/3. Keep the rest for extra. Do not "choke" the heater. Ideally, leave one of side rock compartment open. Choking the heater can result in nuisance hi-limit tripping at low temperatures.



SAUNA CRAFT FM SERIES HEATER DETAIL

FM SERIES HEATER (12 - 18 kw)

SAUNA CRAFT "FM" heaters are floor standing heaters. The heater must be installed at least 4" from all adjacent surfaces (e.g. walls, guard fence, ect...) and the minimum ceiling height must be 84".

The controls are located on the outside wall of the sauna, preferably beside the door. Only the sensor bulb is located inside the sauna and is to be mounted 1' to 2' from the heater, at the ceiling

ROUGH IN CONTROL BEFORE THE WALLS ARE CLOSED UP.

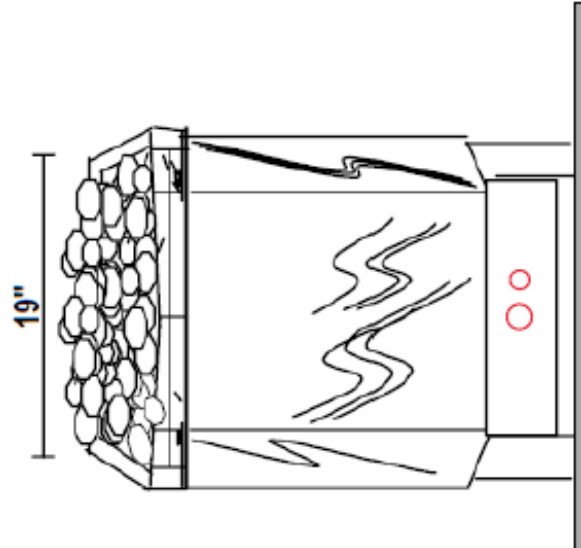
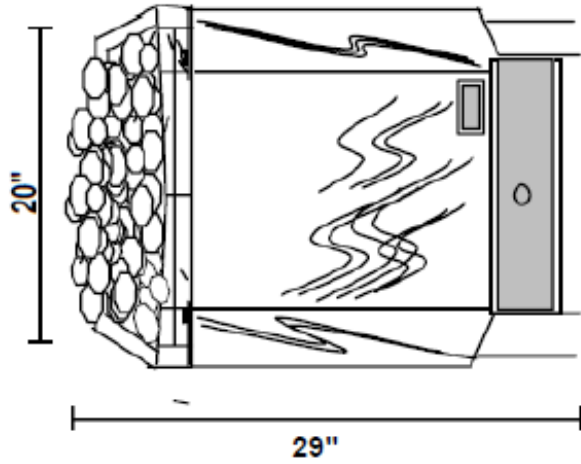

CEILING

Sensing Bulb:
1'-2' away from heater, 1" max. from ceiling
TP/T3: (hang suspended-no metal clips)
EL-13: (secure to ceiling)

55" minimum

4"

ROCKS

Do not "choke" the heater. Stack rocks in a loose pyramid style, leaving pockets of air. You should be able to glimpse the elements hear and there. Choking the heater will result in nuisance hi-limit tripping at low temperatures.