

Sense EP TROUBLESHOOTING
(prepared by Saunafin)

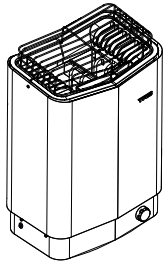

240-volt, single phase

Model	Output (kW)	Copper Wire size	Amps	Breaker
Combi 7	7	8	29.2	40
Combi 8	8.3	8 </td <td>34.6</td> <td>50</td>	34.6	50

Note: Heater rating label shows input for 208v and 240v. Heating elements do not change. The heater output will change based on the voltage applied to heater.

Typical home in USA & Canada is 240-volt, single phase.

Sensor cable can also be connected to jack #4

Control cable can also be connected to any of jack 6,7,8 or 9

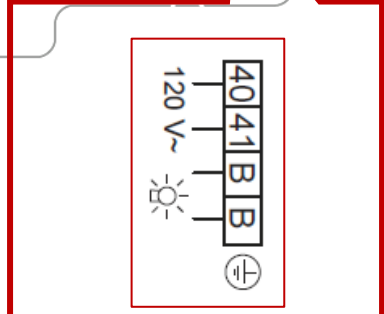
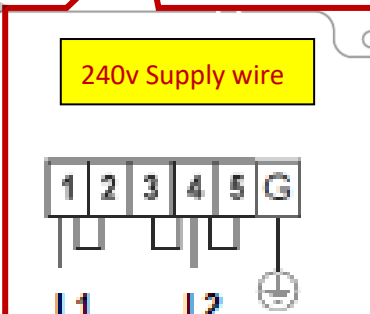
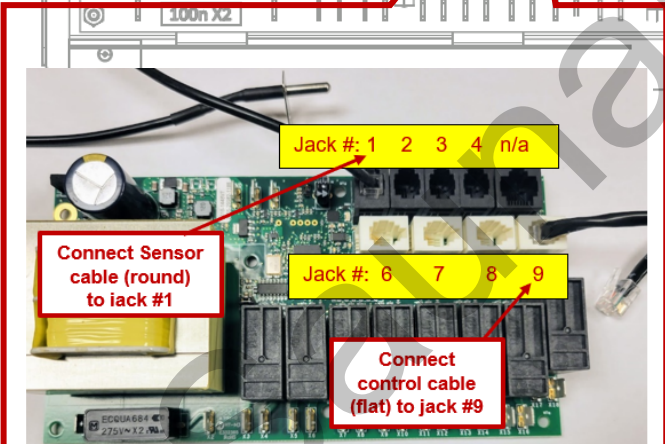
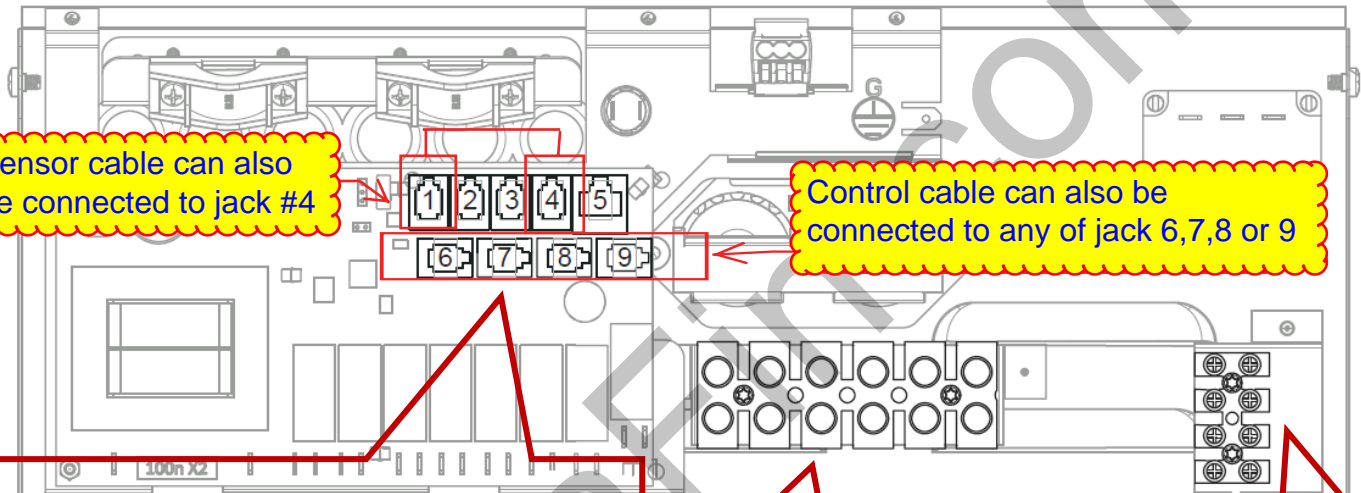

Standard control cable length is 15 feet. Longer available for order if required. We discourage splicing or trying to make your own longer cable.

Sensor cable is standard 15'. No option. No need for longer as specified location is close to heater.

Confirm 3X copper connectors installed

For use only if you want to use sauna control to operate your light (not dimmable). Requires separate 120v supply. (Do NOT take 120v from main 240v supply.)

Heater junction box is a tight fit. Ensure no bare wires make contact with circuit board, or other heater components. When closing junction box cover to ensure wires are not being pushed out of position or trapped in cover.

Some prefer or are required to make a weather-proof connection. You may use Liquid tight conduit for the wire exposed within the sauna. For more flexibility, you can install weather proof junction box inside sauna below heater and use flexible SOOW wire to connect to heater

Temperature Sensor Location

Sensor location is very specific and very important for proper function of the sauna heater. Sensor must be 3" to the front or open side of heater (not in corner), 1" down from ceiling.

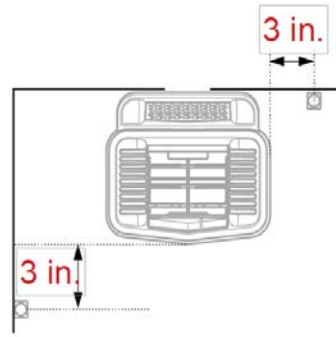
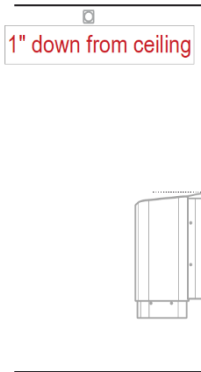

Temperature Sensor Installation

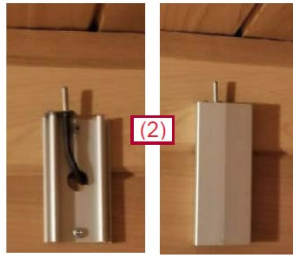
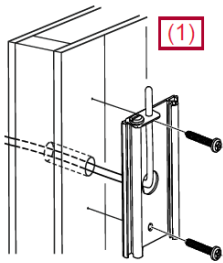

1. Using Sensor Cover: To hide cable inside wall cavity, you must first feed the sensor wire through the sensor holder, then run wire inside the wall, down to area where heater is to be installed.
2. Sensor tip mounts to top of sensor, 1" maximum down from ceiling. Place cover over holder, making sure not to cover sensor itself.
3. Do NOT mount sensor holder on top of sensor after the fact. (This can affect sensor reading and affect sauna operation).
4. Many choose to install bare sensor without holder and cover. Arguably, this is optimal installation as sensor is fully exposed to air temp, not metal (cover) and more accurately reflects air temperature.

SAUNA VENTILATION

Indoor Sauna: Position the air inlet and outlet vents as far away from one another as possible (diagonally opposite). The outlet vent should be located high on a wall (A), and should be about 19" sq. should be directed back into house – it should not be discharged directly to the outside. If outlet wall is inaccessible, install outlet vent in far corner of ceiling. Duct over drop ceiling to area in front of sauna (B).

Outdoor Saunas: Outdoors generally have easy access. Some choose to hold off on vents initially and add later if it appears to be necessary.)

Do not install inlet and outlet vents on same wall. Bad ventilation can be worse than no ventilation.

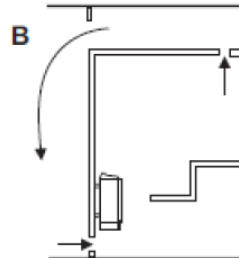
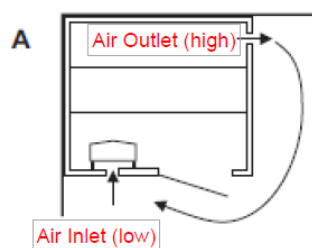
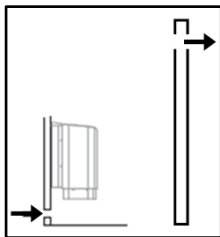

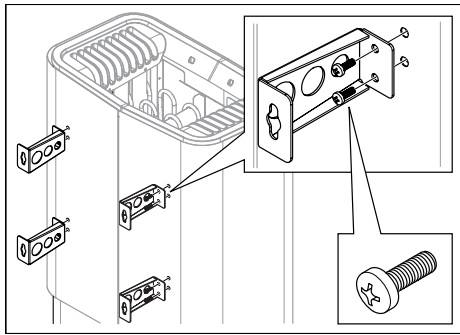

Unscrew the first two screws on the back of the heater and screw one of the four brackets into place. Repeat the procedure until all of the brackets are fitted see Fig. 11.

Note: If all the screws on the back are unscrewed simultaneously, the back plate may come loose. For this reason, attach the four brackets to the heater one at a time.

Figure 11: Attaching the brackets to the heater

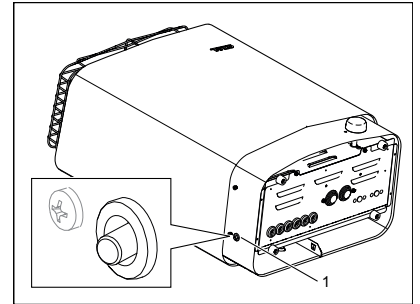

Resetting the temperature cut-out
Temperature cut-out sauna heater

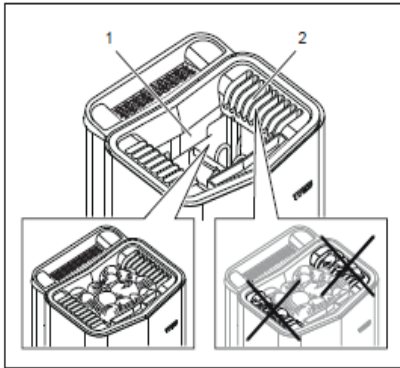

Very Important:

Clean rocks before use to remove dust.

Sauna rocks may only be placed in center (deep) rock compartment (1). Never place stones on top of the side air chambers (2). This will obstruct air circulation, causing the unit to overheat and the cut-out switch to activate.



CONTROL INSTALLATION INSTRUCTIONS

The control panel can be installed inside or outside the sauna room. **If the control is installed inside the room, install no higher than 3' (90 cm) above the floor. No closer than 12" (30 cm) to heater.**

Before applying the control to the wall, connect it to the heater and electrically test everything first.

INSTALLATION WITHOUT BRACKET

Cut a 1-3/16" (3 cm) hole through the wall big enough for the control panel connector. Clean the surface where the control will be applied to remove all dust. Attach the double-sided adhesive to the control panel. Remove the protective backing from the adhesive and press the control panel firmly to the wall. Silicone sealant can be applied as an extra seal.

INSTALLATION WITH BRACKET

Use the mounting bracket as a template to mark screws holes on the wall. Cut a 1-3/16" (3 cm) hole through the wall big enough for the control panel connector. (If control cable to be surface mounted, connector can be fitted in back of mounting bracket.). Use adhesive to mount the control to the bracket.

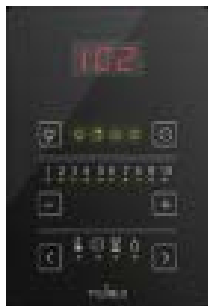

See Control box for instructions on how to operate Pure 2.0 control.

LED Error code Pure Control

If an error should occur on the heater or other equipment (control panel, temperature sensor etc.) an error message will be shown using LED indicators. The indicator LEDs will flash whilst one LED on the 1-10 scale is continuously lit or flashes. If it lights continuously, it refers to error message 1-10 and if it flashes, it refers to error messages 11-20.

Error messages (– indicates not relevant to this application):

1. Temperature sensor not connected or faulty
2. -
3. Heater circuit board overheated
4. The level electrodes in the tank are short-circuited (Combi)
5. -
6. Contact between heater and control panel lost
7. Contact with temperature/humidity sensor lost
8. -
9. Communication with timer lost
10. Current to timer disrupted
11. -
12. The level electrodes are not working. Mid. failure. (Combi)
13. Humidity sensor faulty
14. Temp. sensor faulty
15. Communication problem with heater
16. Temperature cut-out activated and must be reset
17. -
18. -
19. Door has been open for more than 5 minutes when the sauna is on.
20. Door has been opened. Check sauna.

For certain errors, disconnecting current to the heater for a brief period and then reconnecting can be tried. This mostly concerns problems that have occurred with communication between units connected.

In the event of error number 3, the heater will be automatically switched off. When the temperature has dropped approx. 20°C, the sauna heater can be restarted. Always investigate why the heater overheated. It can be the result of insufficient ventilation or that the heater needs crumbled stone removed.

Contact your dealer for other errors or if an error cannot be corrected according to the above. Check the heater's type plate and note the type, serial number, year of manufacture and make a note of any error code on the control panel before contacting Tylö Customer Support.

Error message Elite Control

Should an error occur in a device or associated equipment (control panel, temperature sensor, etc.) an error message will be displayed (see Error list).

The following error codes are used:

No.	Error	Comments/Troubleshooting
1	Temperature sensor in the room not connected or faulty.	Is the sensor at the input intact/interrupted? Is it indicating an incorrect value or loose?
2	Temperature sensor in steam tank not connected or faulty.	Is the sensor at the entrance intact/interrupted? Is it indicating an incorrect value or loose? The sensor value is displayed under the water temperature status under Configure. On operation is not interrupted if an error occurs. Standby operation not permitted.
3	The relay board has overheated.	Wait until the temperature drops to 20 °C; it should be possible to start it after that. If the temperature remains too high the error will recur.
4	The level electrodes in the steam tank are short-circuited.	Check that the electrode pins are touching the electrode tube or alternatively the cables. Clean the water tank and level pins.
6	Contact lost with the control panel..	Are the control panel's RJ10 connections loose? Poor connection?
7	Contact lost with temperature/humidity sensor.	Are the temperature/humidity sensor's RJ10 connections loose? Poor connection?
9	Real-time clock (RTC) communication error.	Has the system lost power for a long period? Set the time and date.

Error codes (continued)

No.	Error	Comments/Troubleshooting
10	Contact with the add-on board has been lost.	Check the RJ45 cable between the circuit board and the add-on board. Is the green LED lit on the add-on board? Try to start ON operation again to try and restore the contact. Try replacing the RJ45 cable or add-on board.
12	Steam tank level electrodes are not working, mid failure.	Check the cable connections between the circuit board and the mid electrode. Check if the mid electrode pin is coated with surface coating; if so, clean the electrode pin.
13	Humidity sensor is not working.	Try restarting the system or replacing the temperature/humidity sensor that is connected to the RS485 input.
14	Temperature sensor not working.	Try restarting the system or replacing the temperature/humidity sensor that is connected to the RS485 input.
15	Contact lost with the relay board.	Appears when the primary unit has lost contact with the connected secondary unit. The system will fix itself. Check synchronisation cables and voltage to secondary units. After the error is rectified, the system reboots to include all secondary units in system operation.
16	Temperature cut-out activated and must be reset manually.	Combined temperature cut-out/temperature sensor in sauna is reset via a push button on the sensor.

Information!

Contact the dealer during the guarantee period in the event of faults.
See the instructions for the control panel for details of faults not covered in this user guide.

Table 1: Troubleshooting the sauna heater

Symptom	Possible cause	Remedy
First time use. Heater does not operate	<ol style="list-style-type: none"> 1. Breaker off 2. U-shape copper connectors not installed. 3. Sensor or control cable plugged into wrong jack 	<ol style="list-style-type: none"> 1. Turn on Breaker 2. Have electrician confirm proper installation (fig.19) 3. Have electrician confirm proper installation (fig.19)
Heater is on but does not create steam.	<ol style="list-style-type: none"> 1. Water level incorrect. Below minimum water level for safety sensor? 2. Humidity settings not programmed as intended 3. Water reservoir temperature cut-out activated? 4. Heater element in reservoir faulty? 5. If the sauna structure has deficient ventilation in conjunction with dry sauna and high sauna temperature (operating with no water in reservoir), the temperature cut-out can activate because of higher radiating temperature in the heater. 	<ol style="list-style-type: none"> 1. Fill up reservoir. 2. Confirm control setting-review control manual. (For max. steam, set humidity to "10 & temp. to "1") 3. Reset temperature cut-out. For more information, see the section on temperature cut-out on figure 9 page 15 in full manual. If the steam function does not work after reset, there is a risk of the reservoir being damaged. 4. An authorized electrician is required to find the fault. 5. Check for possible deficient ventilation.
Heater element in heater stone compartment does not warm up.	<ol style="list-style-type: none"> 1. Temperature settings not programmed as intended 2. Water reservoir in operation? Only two of the three heater elements in the stone compartment can operate at the same time as the tank, otherwise excessive current is drawn from the electricity supply. This is not a fault outside normal operation. 3. Some of the heater fuses on the main switchboard can have tripped out? 4. Resistor coil in the heater element faulty? 5. Internal heater PCB fault? 	<ol style="list-style-type: none"> 1. Confirm control setting-review control manual. (For max. temp, set humidity to "1" & temp. to "10") 2. See the instructions supplied with the control panel. 3. Check and replace/reset the fuses in the main switchboard. 4. An authorised electrician is required to find the fault. 5. An authorised electrician is required to find the fault.
Lights in the sauna do not come on when switched on at the control panel.	<ol style="list-style-type: none"> 1. Light was not connected to the heter. (Requires a separate 120 volt supply to heater) 2. Internal heater PCB fault? 	<ol style="list-style-type: none"> 1. Verify with authorized electrician who performed installation of heater/lighting. 2. An authorized electrician is required to find the fault.
Heater does not work, control panel does not light up.	<ol style="list-style-type: none"> 1. The main power switch is off? 2. Circuit breaker tripped on main electrical panel. 3. Loose contact in cabling between heater and control panel? 4. Modular jack is not properly installed at heater PCB circuit board. The specific 12VDC output on one of the PCB's RS485 modular jack to the control panel is faulty due to short-circuit? 5. Transformer on PCB in heater faulty? 6. Control panel faulty? 	<ol style="list-style-type: none"> 1. Turn heater main power switch. 2. Check and replace/reset the fuses in the main switchboard. 3. Switch off heater main power switch and connect each/paired cable to the control panel. Switch on heater main power switch again. If this does not help, an authorized electrician is required to find the fault. 4. Requires an authorized electrician to find the fault, faulty 12VDC output is indicated by LED out next to the RS485 output. Note: if the fault is in the RJ10 cable to the control panel, do not click into a working vacant RS485 outlet to avoid causing a fault in that outlet. RJ10 cable must be replaced/contacts fitted in the event of a fault. 5. An authorized electrician is required to find the fault. 6. An authorized electrician is required to find the fault.
The fuses or circuit breaker in the building breaker panel trips as soon as the heater is turned on.	<ol style="list-style-type: none"> 1. There is a short-circuit at the heater GND. Can be due to a faulty heater element? 2. Lighting connected to and controlled via the heater faulty? 3. The heater has not been used for a long period, causing an insulation fault in the heater element? 4. Heater has had too much water poured on it? 5. Other internal heater fault? 6. GFCI breaker tripped 	<ol style="list-style-type: none"> 1,2,3,4,5. Do not use the heater, switch off at main heater main switchboard trip and disconnect heater fuses on the main switchboard. An authorized electrician is required to find the fault. 6. Saunas should not have GFCI breaker. Have electrician replace with standard breaker
Water reservoir temperature cut-out activated	<ol style="list-style-type: none"> 1. Dry boiling, incorrect minimum water level. 2. Foam in the water reservoir. 	<ol style="list-style-type: none"> 1. Drain and clean water reservoir. 2. Clean level electrodes.
Heater does not work, control panel does not light up	<ol style="list-style-type: none"> 1. Temperature cut-out activated. 2. Change, rearrange stones, clean stone compartment. Possible deficient ventilation. 	<ol style="list-style-type: none"> 1. Reset High limit switch.(See page 5 in full manual) 2. Possible deficient ventilation. Improper ventilation can cause high limit to trip.(See page 5 in full manual)
Heater works but do not reach set temperature.	<ol style="list-style-type: none"> 1. Incorrect placement of sensor. 2. Incorrect ventilation. 3. Incorrect heater. 	<ol style="list-style-type: none"> 1. Confirm sensor is placed as per instructions.(fig.3) 2. Check ventilation. 3. Check that heaters size is according to recommendation for the sauna volume.