

Electronic Control Operation Manual (EL-13)

3-gang box

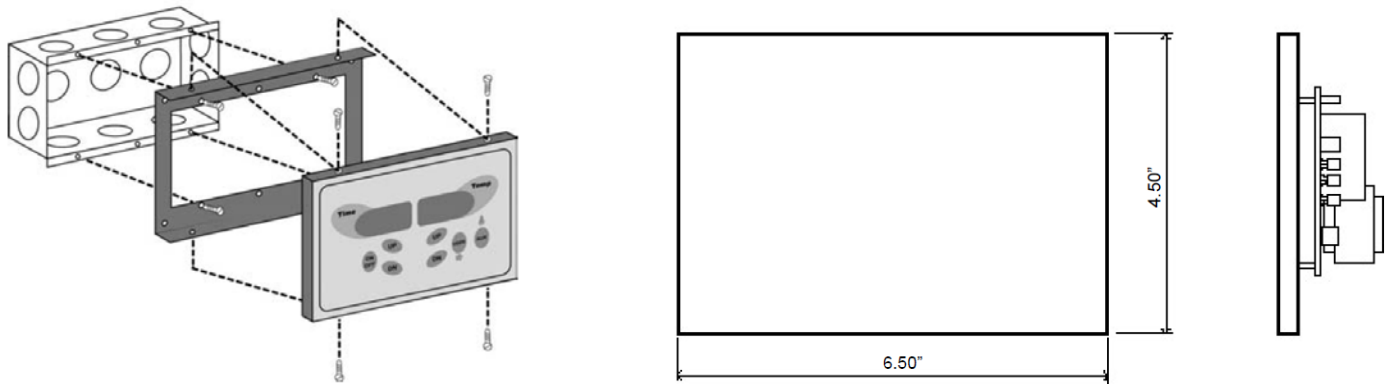

Idle: When control is inactive, it will show “O” in time window and

Start: Press “**ON/OFF**”.
Sauna defaults to 60 minutes and maximum temperature (90C or 194 F).

When operational, time window will flash between the word “on” and setpoint and time remaining and actual temperature.

When the control is engaged, a small dot will flash in the time window.

Off: Pressing the “**ON/OFF**” a third time will turn off the sauna.

Temperature: Use the “**up**” and “**down**” icons, on the “Temp” side (right) to set the desired temperature.

Time: Use the “**up**” and “**down**” icons, on the “Time” side (left) to set the desired time.

Light: Light Function not available

C. vs. F.: Controls generally come either Celsius or Fahrenheit as ordered.

TROUBLESHOOTING:

The sensor wiring and controls are continually checked for proper operation. If a malfunction is detected, the controller will automatically switch OFF the load and deactivate itself. At the same time the display will show “Err”. The controller cannot be reactivated until all causes of the malfunction are fixed.

EL-13 CONTROL

CONTROL TO BE INSTALL OUTSIDE OF SAUNA (i.e.front wall, next to door)

4 KW, 5 KW & 6 KW / 240 Volt / 1 PHASE

Sensing bulb comes with pigtail. Sensing bulb should be located at ceiling 3' -4' from heater. 12' of capillary wire included. (If additional length required, use 18ga or 20ga to extend)

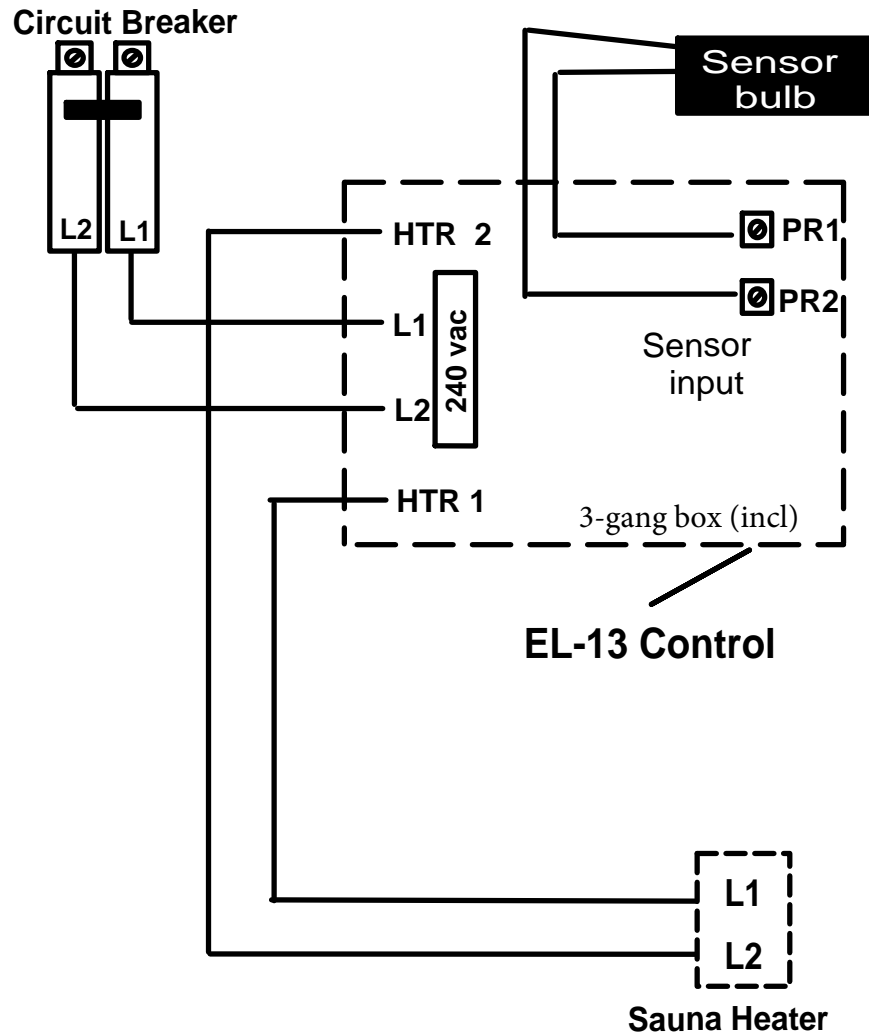

EL-13 CONTROL INSTALLATION AND OPERATION

<u>Watts</u>	<u>Volts</u>	<u>Phase</u>	<u>Wire Size</u>	<u>Circuit Breaker</u>
4000	240	1	10	30
5000	240	1	10	30
6000	240	1	8	40

Operation

** See programming instruction sheet for set up of control

Installation Tips

1. Avoid static build up when control sensor bulb are handled.
2. Avoid running sensor bulb capillary wire too close to line power lines.
3. #10 SEW wire with spade connector included. For use with 6kw heater with #8 supplier

EL-13 CONTROL with CONTACTOR

For Heaters 7.5 kw & larger

Ensure that correct voltage is applied to the contactor coil.

- Control Wire (#14)
- Supply Wire
-Dotted Line for 3 Phase Only

Sensing bulb comes with pigtail. Sensing bulb should be located at ceiling 3' -4' from heater. 12' of capillary wire included. (If additional length required, use 18ga or 20ga to extend)

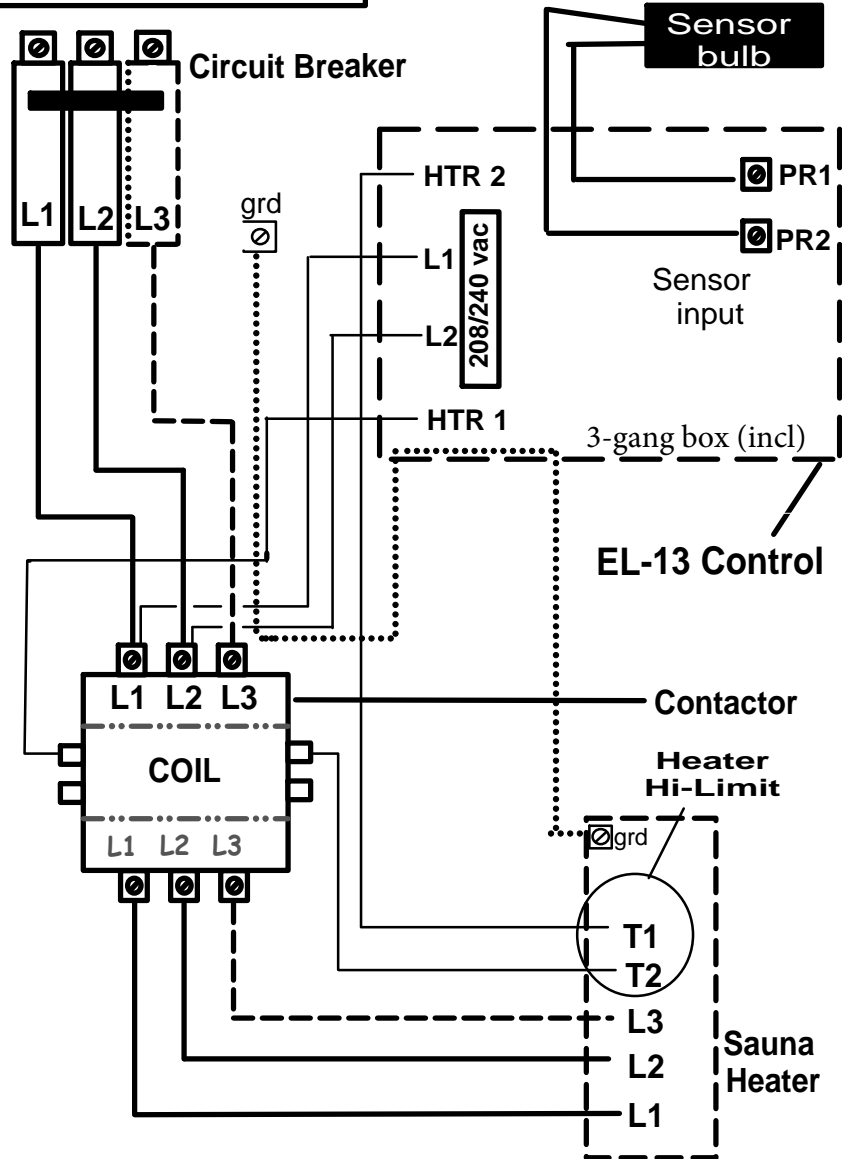

CONTACTOR DETAIL

Install contactor between breaker and control. Most are installed next to breaker panel. Following examples of the different contactors depending upon heater wattage and phase. The broken lines represent the coil in the middle of the contactor.

For 7.5 - 9 KW single phase units.
 40 Amp. Res. (7.5 kw, 240 v, 1 phase)
 50 Amp. Res. (9 kw, 240 v, 1 phase)

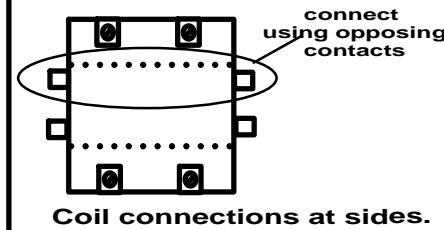

For 12 KW 1 phase units.
 63 Amp. Res. (12 kw, 240 v, 1 phase)

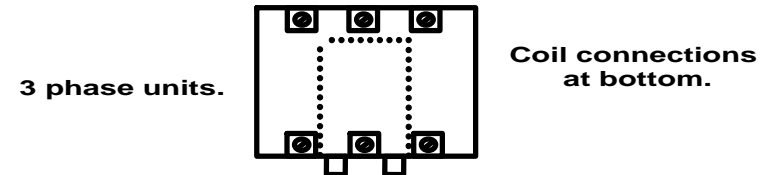
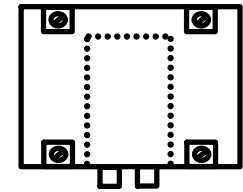

3 phase units.
 40 Amp. Res. (6kw to 12 kw, 208 v, 3 phase)
 50 Amp. Res. (15 kw, 208 v, 3 phase)
 63 Amp. Res. (18 kw, 208 v, 3 phase)

Watts	Volts	Phase	Wire Size	Circuit Breaker
6000	208	3	10	30
7500	240	1	8	40
7500	208	3	10	30
9000	240	1	8	50
9000	208	3	8	40
12000	240	1	6	60
12000	208	3	8	50
15000	208	3	6	60
18000	208	3	6	70

**7.5 kW & larger
With Contactor**

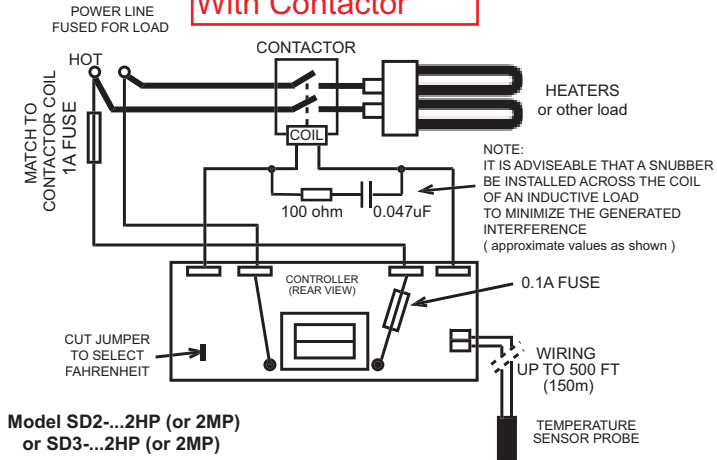

**WIRING FOR HIGH POWER
HEATERS WITH CONTACTOR CONTROLLED THROUGH 2 RELAYS**

W1

**4 -6 kW, 240 volt
Without Contactor**

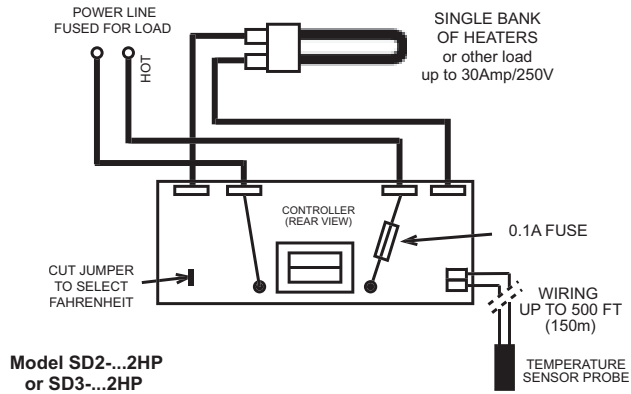

**SIMPLE WIRING FOR
HEATERS THROUGH 2 RELAYS**

W3